

DCmind Brushless gearmotor 80 149 642

Data sheet

Series



80 149 6 SMI21

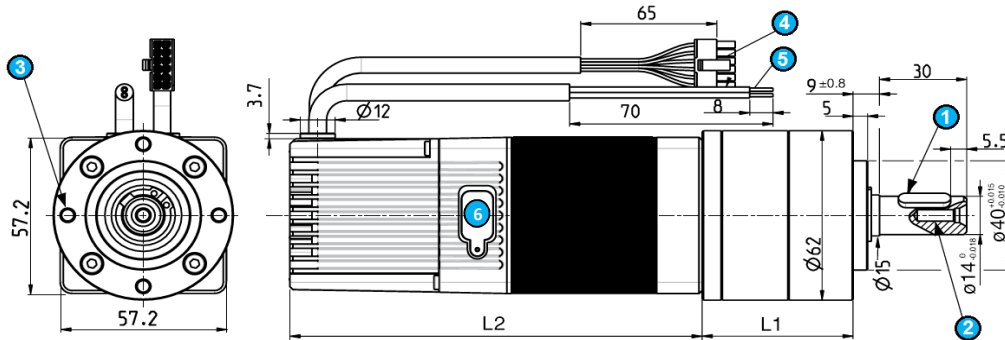

- 1 Parallel key 4 x 4 x 16 DIN6885A
- 2 M4 x 10
- 3 4 x M5 on diam 40 mm - 10 mm depth

- 4 Input - Output cable / 500 mm + 20
- 5 Power supply cable / 500 mm + 20
- 6 Micro-USB B connector

L1 = 52,1 +0,7
L2 = 123 max.

General characteristics

Power supply		
Direct current voltage supply		✓
Nominal voltage range (6)	Vdc	12 -> 72
Max. current	A	10

Gearmotor type 80 149 6 SMI21		
Motor type		80 140 043
Gearbox type		81 049 6
Gear ratio		6,75
Number of stages		1
Max. allowed torque	Nm	8
Max. gear play	°	0,65

Motor characteristics (1)				
At no load				
		12 Vdc	24 Vdc	48 Vdc
Max. output speed	rpm	341	593	593
Current at the max output speed (7)	A	0,35	0,35	0,2
Standby current	A	0,1	0,05	0,025
At nominal				
Speed	rpm	216	556	593
Torque (4)	Nm	1,4	1,4	1,4
Output power	W	31	80	85
Current	A	4,7	4,7	2,4
Efficiency	%	55	70	74
At max. output power				
Speed	rpm	181	444	576
Torque (4)	Nm	1,8	2,4	2,7
Output power	W	34	113	161
Current	A	6,40	8,90	5,80
Efficiency	%	45	53	58
At peak torque				
Speed	rpm	79	427	576
Torque (4)	Nm	2,7	2,7	2,7
Output power	W	22	119	161
Current	A	10	10	5,8
Others				
Weight	kg		1,97	
Noise level	dBA		50	

Connecting	
Input - Output cable	With Molex connector ref: 43025-1200
Output cable, UL style 2464 80°C 300V - 12 wires AWG26	
Input 1 (digital)	1 - Green
Input 2 (digital)	2 - Yellow
Input 3 (digital)	3 - White
Input 4 (digital)	4 - White/brown
Input 5 (analogic)	5 - Blue
Input 6 (analogic)	6 - Orange
OV	7 - Black
OV	8 - White/black
Output 1 (digital - PWM)	9 - Brown
Output 2 (digital - PWM)	10 - Purple
Output 3 (digital)	11 - Red
Output 4 (digital)	12 - Gray
Power supply cable	
Cable UL style 2517 105°C 300V - 2 wires AWG16	
+ 12Vcc -> + 72 Vdc (6)	Brown
OV	Blue
Connector for settings	
Connector type	Micro-USB B

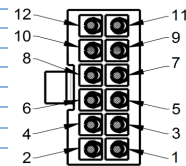

Drive	
Type	SMI21
Built-in drive	✓
Internal encoder	4096 pulses/turn
Setting software on PC	DCmind Soft

Control	
Position - speed - torque	✓
4 quadrants with regenerative energy	✓
Type" Field Oriented Control"	✓
Pulse counter range	+ - 31 bits

Security	
Output cut-short	✓
Input inverted	✓
Low voltage	Vdc < 8
Short high voltage (6)	Vdc > 100
Internal drive temperature protection (2)	°C 110
Drive temperature allowing to restart	°C 90

Generic parameters			
Motor for direct current supply		✓	
Output shaft with ball bearings		✓	
Max. Radial force (12mm from front face)	N		240
Max. axial force (5)	N		70
Temperature range	CEI60068-2-1/2	°C	-30 -> +70
Storage temperature		°C	-40 -> +80
Dielectric (1s/2mA/50Hz)	CEI60335	Vac	1 000
Motor insulation	CEI60085	class	E
Salt spray	CEI60068-2-52	level	2
Degree of protection (output shaft not included)	CEI60529	IP	65
EMC			
Electrostatic Discharge	CEI61000-4-2	level	3
Radiated radio frequency	CEI61000-4-3	level	3
Electrical fast transient / burst test	CEI61000-4-4	level	3
Surge test	CEI61000-4-5	level	1
Conducted disturbances	CEI61000-4-6	level	3
Radiated emission	EN55022	class	B
Approvals			
ROHS	2011/65/UE	✓	
EC	2014/30/UE	✓	

Notes	
Values without tolerance, are average production values.	
Added informations are in "SMI21 manual and security". Available on www.crouzet-motors.com and in the "Discovery kit"	
Motor not protected in case of reversed power voltage	
(1)	Cold motor, 20 ° C ambient temperature, full speed
(2)	With max.torque (limit tab) lower than peak torque
(4)	Max torque for continuous operation at 20 ° C, decrease this value for higher ambient temperature
(5)	Pinion or pulley fitting are done at the Crouzet factory, before final assembly.
(6)	Value upgraded in September 2015. The value was different before to this date.
(7)	Value without gearbox. With gearbox, the value increases and varies depending on grease temperature.

Specifications subject to change without notice. Updated 25/07/2016

Drive electrical datas

Absolute maximum ratings			
Parameters			
Max. voltage supply "Vcc max" (6)	Vdc		100
Max. current "Icc max"	A		12
Max. voltage on inputs "Vin max"	Vdc		50 / 75
Max. voltage on outputs "Vout max"	Vdc		100
Max. output current "Iout max"	mA		50
Running datas			
Parameters			
Voltage supply "Vcc" (6)	Vdc	Min.	Typical
			Max.
Voltage supply "Vcc" (6)	Vdc	9	12 -> 72
Current "Icc"	A	-	5
Standby power "Wo"	W	-	1
Speed setting	rpm	0 / 0,15	-
Torque setting	Nm	0	-

Input datas			
Parameters			
Impedance - Input 1, 2, 3, 4	Ω	Min.	Typical
			Max.
Impedance - Input 5, 6	Ω	-	57
		-	69
Low level - Input 1, 2, 3, 4	Vdc	0	-
High level - Input 1, 2, 3, 4	Vdc	4	-
Low level - Input 5, 6	Vdc	0	-
High level - Input 5, 6	Vdc	7,5	-
Output datas			
Parameters			
Low level Output 1, 2, 3, 4	Vdc	Min.	Typical
			Max.
Low level Output 1, 2, 3, 4	Vdc	0	-
with "pull down resistor" = 4,7K Ω and Vcc = 24 V			0,2
High level Output 1, 2, 3, 4	Vdc	Vcc - 0,5	-
with "pull down resistor" = 4,7K Ω and Vcc = 24 V			Vcc
= voltage supply added from eventual rejective voltage			
Notes			
Outputs are destroyed if they are connected to zero ground or to a capacitive load			

Speed-torque and current-torque curves

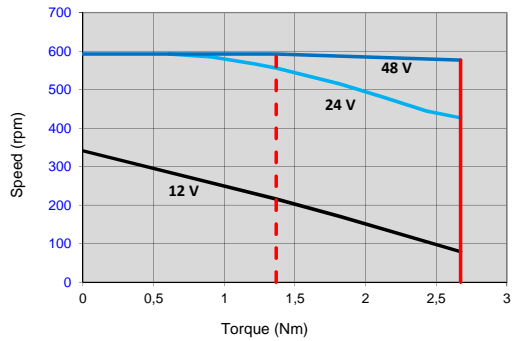

..... Nominal torque

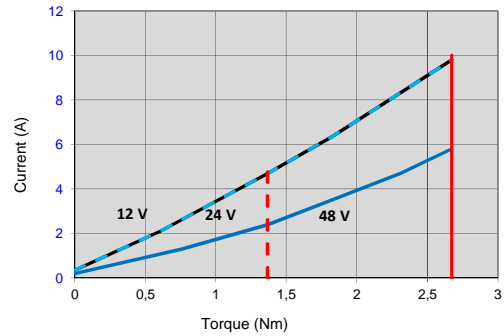

..... Peak torque

Wiring

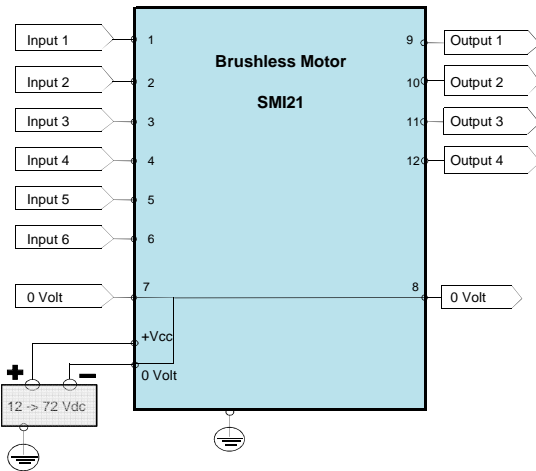

Output equivalent circuit

Output 1,2,3,4

Add a pull down resistor

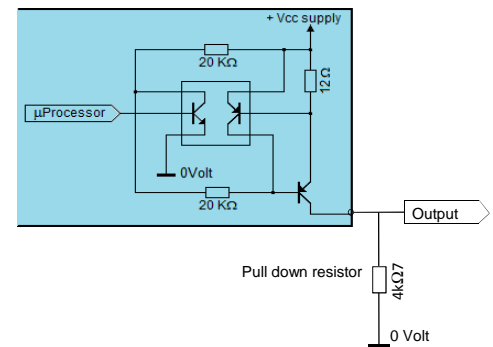

Input equivalent circuit

Inputs 1, 2, 3, 4

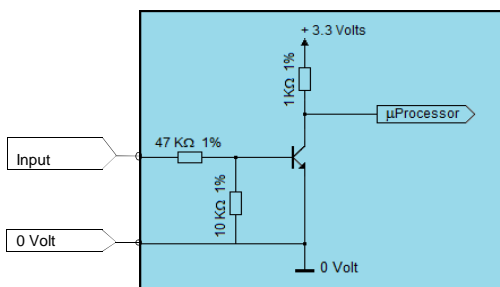

Inputs 5, 6

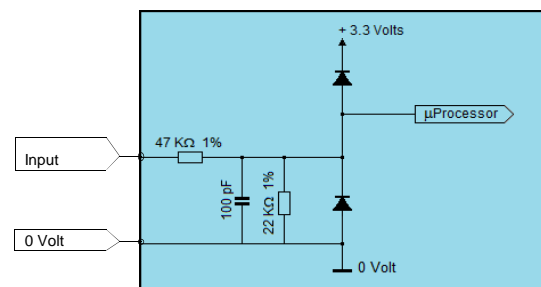

Accessory

Discovery kit	
Part number	79 298 008
Includes: a MicroUSB - USB cable and a memory stick with Dcmind Soft program	