

8B0F0160H000.000-1

1 General information

- Wide mains input voltage range
- Optimized for ACOPOSmulti 8B0P power supply modules and ACOPOS P3
- Compliance with limit values per CISPR11, group 2, class A

Information:

In order to conform to the EMC limit values, all 8BVI inverter modules in the drive system connected to the 8B0F line filter must be operated at the nominal switching frequency (5 kHz). The total length of all motor cables on each drive system (and for each 8B0F line filter) is not permitted to exceed 250 m. The cable length between the 8B0F line filter and the 8B0P power supply module is not permitted to exceed 5 m. The maximum permissible motor cable length per motor connection must also be taken into account (see 8BVI inverter modules).

2 Order data

Order number	Short description	Figure
	Passive line filter	
8B0F0160H000.000-1	Line filter, passive, 16 A, 3x 528 VAC, 50/60 Hz, IP20	

Table 1: 8B0F0160H000.000-1 - Order data

Allocation to power supply module

	8B0F0160H000.A00-1	8B0F0160H000.000-1	8B0F0300H000.000-1	8B0F0550H000.000-1
8B0P0220Hx00.00x-1	X	X	X	
8B0P0440Hx00.00x-1				X

Table 2: Allocation to power supply module

3 Technical data

Order number	8B0F0160H000.000-1
General information	
Cooling and mounting type	Wall mounting
Certifications	
CE	Yes
UKCA	Yes
UL	cULus E225616 Power conversion equipment
Mains connection	
Permissible network configurations	TT, TN ¹⁾
Mains input voltage	Max. 3x 528 VAC
Frequency	Max. 60 Hz
Continuous current	16 A _{eff} ²⁾
Peak current	24 A _{eff} (<1 min), 1x/h

Table 3: 8B0F0160H000.000-1 - Technical data

Order number	8B0F0160H000.000-1
Reduction of continuous current depending on ambient temperature	
Starting at 50°C	No reduction
Reduction of continuous current depending on installation elevation	
Starting at 2000 m above sea level	15 A up to 3000 m 14.2 A up to 4000 m
Power dissipation ³⁾	6.1 W
Line filter per EN 61800-3, category C3 ⁴⁾	Yes
Variant	
L1, L2, L3 and L1', L2', L3'	Terminals
PE	M5 threaded bolt
Shield connection	
On mains	No
On device	No
Terminal connection cross section	
Flexible and fine-stranded wires	
With wire end sleeves	0.25 to 6 mm ²
Approbation data	
UL/C-UL-US	28 to 8 AWG
CSA	28 to 8 AWG
Electrical properties	
Discharge capacitance	0.4 µF
Leakage current ⁵⁾	33 mA ⁶⁾
Operating conditions	
Permissible mounting orientations	
Hanging vertically	Yes
Horizontal, face up	Yes
Standing horizontally	Yes
Installation elevation above sea level	
Nominal	0 to 2000 m
Maximum ⁷⁾	4000 m
Pollution degree per EN 61800-5-1	PD 3 per EN 61800-5-1 and IEC 60664-1
Overvoltage category per IEC 60950	III
Overvoltage category per EN 61800-5-1	III per EN 60664-1
Degree of protection per EN 60529	IP20
Ambient conditions	
Temperature	
Operation	
Nominal	5 to 40°C
Maximum	55°C
Storage	-25 to 55°C
Transport	-25 to 70°C
Relative humidity	
Operation	5 to 85%
Storage	5 to 95%
Transport	Max. 95% at 40°C
Mechanical properties	
Vibration and shock	3M4 per IEC 60721-3-3
Dimensions	
Width	45 mm
Height	263.8 mm
Depth	70 mm
Weight	0.85 kg

Table 3: 8B0F0160H000.000-1 - Technical data

- 1) TT and TN power systems are commonly referred to as "Delta/Wye with grounded wye neutral" in the USA.
- 2) Valid under the following conditions: 3x 528 VAC mains input voltage, 50°C ambient temperature, cos phi = 0.8.
The exact value depends on the application.
- 3) Valid under the following conditions: 25°C ambient temperature, frequency 50 Hz.
- 4) Limit values from EN 61800-3 C3 (second environment).
- 5) Valid under the following conditions: 3x 400 VAC mains input voltage, 50 Hz frequency.
NOTE: Increased leakage currents may occur when switching on the mains (short-term single-phase or two-phase operation resulting from contact bounce in the line contactor) due to higher-frequency leakage currents occurring during operation with long motor cables or strong imbalances of the three-phase system. Observe the information in section "Dimensioning" in the drive system user's manual!
- 6) Value valid for 2% mains asymmetry per EN 50160. The value is 36.8 mA for 3% mains asymmetry per EN 61800-3.
- 7) Continuous operation at an installation elevation of 2000 m to 4000 m above sea level is possible taking the specified reduction of continuous current into account. Requirements that go beyond this must be arranged with B&R.

3.1 Derating

Derating curve starting at 50°C

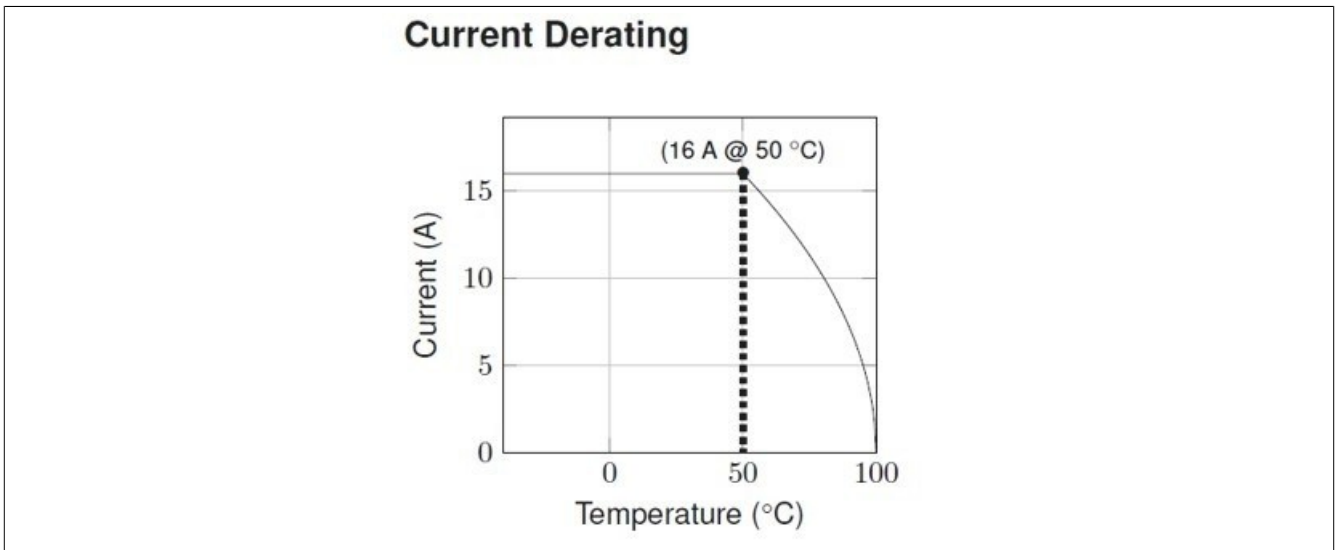

4 Dimension diagram and installation dimensions

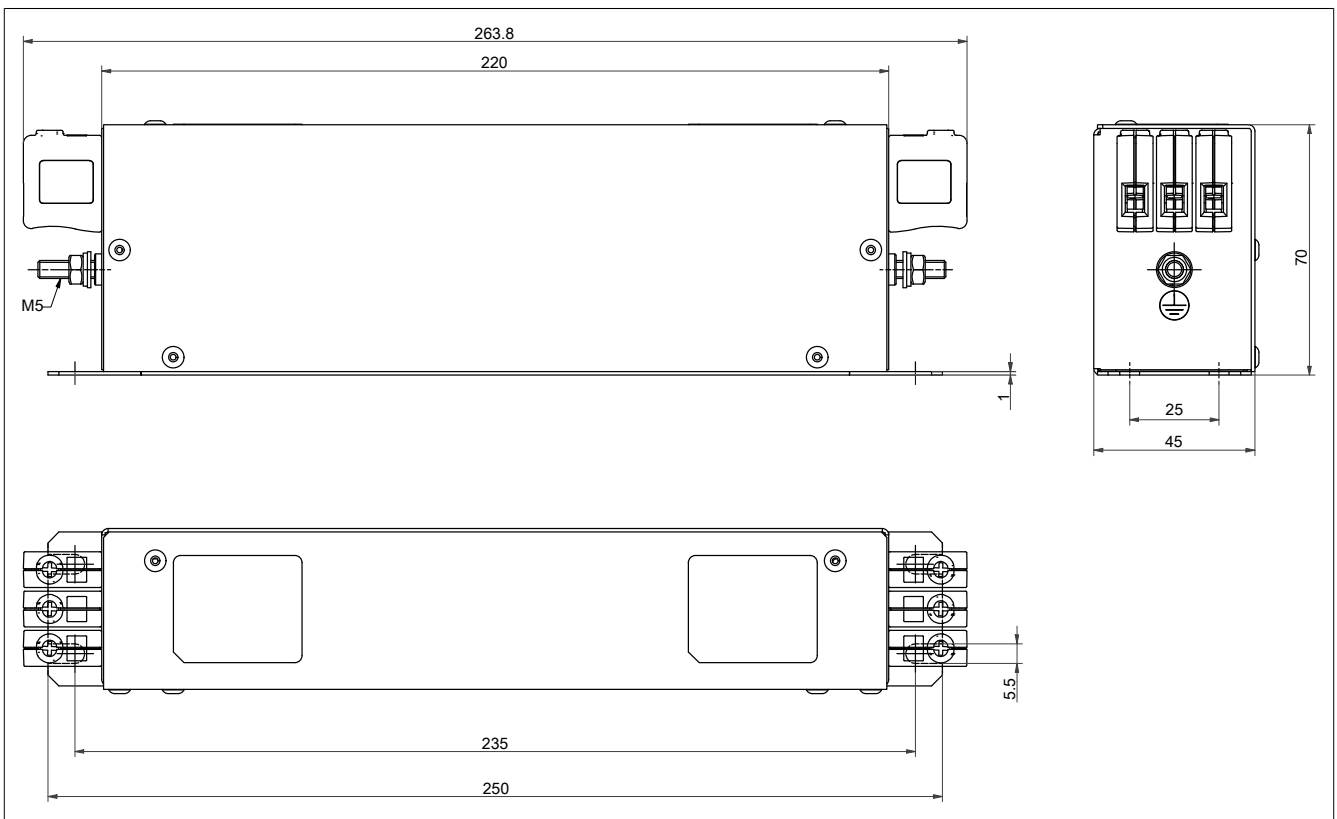

Figure 1: Dimension diagram and installation dimensions

For sufficient air circulation, a clearance of at least 60 mm must be provided above, below and in front of the module.

5 Wiring

5.1 8B0F line filters - Pinout overview

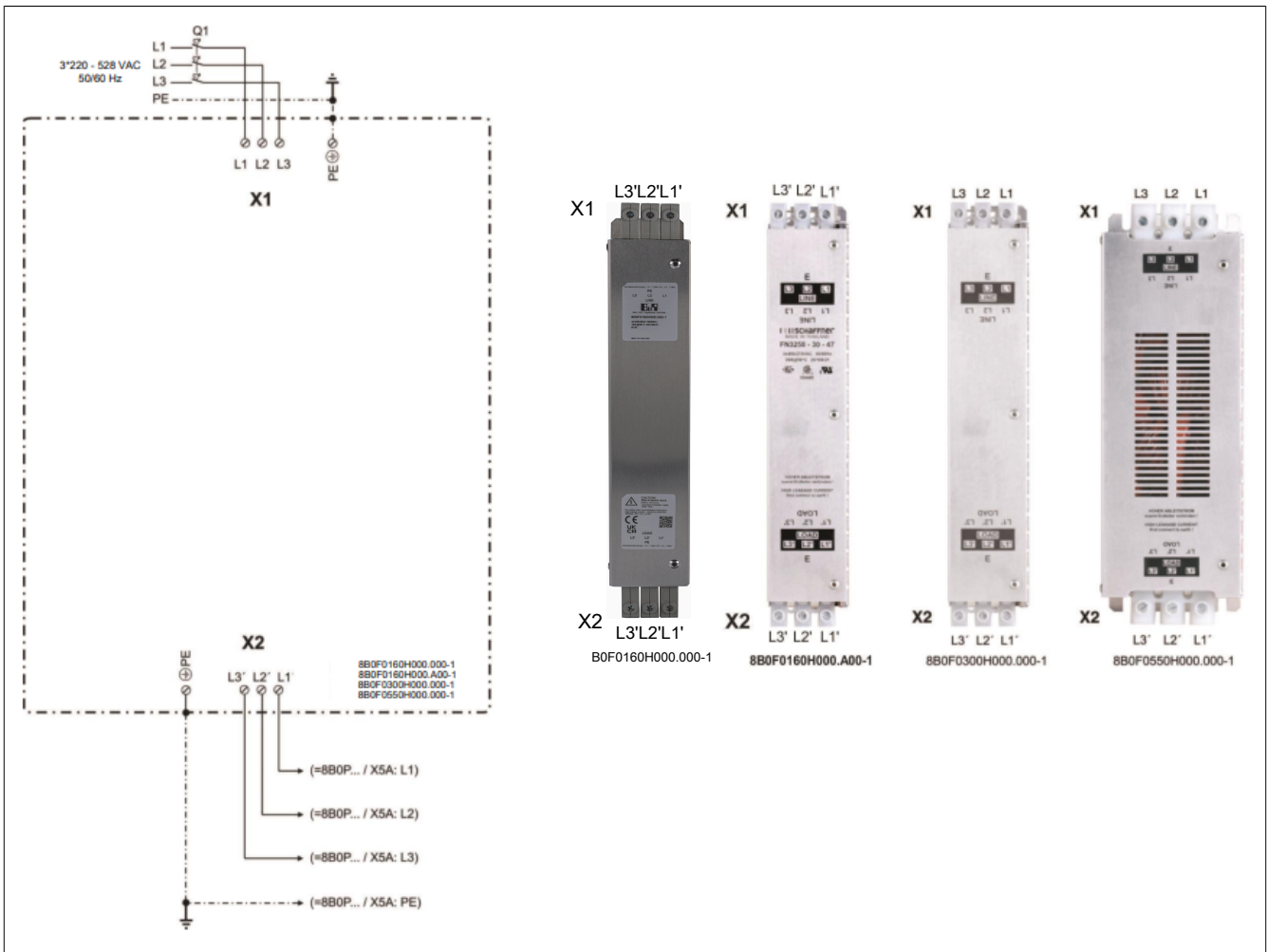

Figure 2: 8B0F0160H000.A00-1, 8B0F0300H000.000-1, 8B0F0550H000.000-1, 8B0F0160H000.000-1 - Pinout overview

5.2 X1 - Pinout

X1	Name	Function
	L1	Mains connection L1 (mains side)
	L2	Mains connection L2 (mains side)
	L3	Mains connection L3 (mains side)
Terminal connection cross section		
Flexible and fine stranded conductors with wire end sleeves UL/cULus CSA		0.25-6 mm ² 28-8 AWG 28-8 AWG
Tightening torque of the terminal screws		1.0-1.2 Nm

Table 4: Connector X1 - Pinout

5.3 X2 - Pinout

X2	Name	Function
	L1'	Mains connection L1 (load side)
	L2'	Mains connection L2 (load side)
	L3'	Mains connection L3 (load side)
Terminal connection cross section		
Flexible and fine stranded conductors with wire end sleeves UL/cULus CSA		0.25 - 6 mm ² 28 - 8 AWG 28 - 8 AWG
Tightening torque of the terminal screws		1.0 - 1.2 Nm

Table 5: Connector X2 - Pinout

5.4 Protective ground connection (PE) (mains and load sides)

The protective ground conductor is secured to the threaded bolt provided for this purpose using a cable lug.

Figure	Pin	Name	Function
	---	PE	Protective ground conductor
	Terminal cross section		
Cable lug for threaded bolt		[mm ²]	AWG
		0.25 - 16	23 - 5
Tightening torque of the clamping screws [Nm]:			2.2 Nm

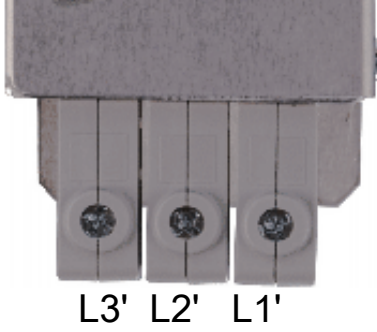
Table 6: 8B0F - Protective ground connection (PE)

Danger!

Before switching on the power supply, it must be ensured that the housing of the line filter is properly connected to ground potential (PE rail). Ground connections must also be made if the line filter is only connected for testing purposes or only operated for a short time!

5.5 Input/Output circuit diagram

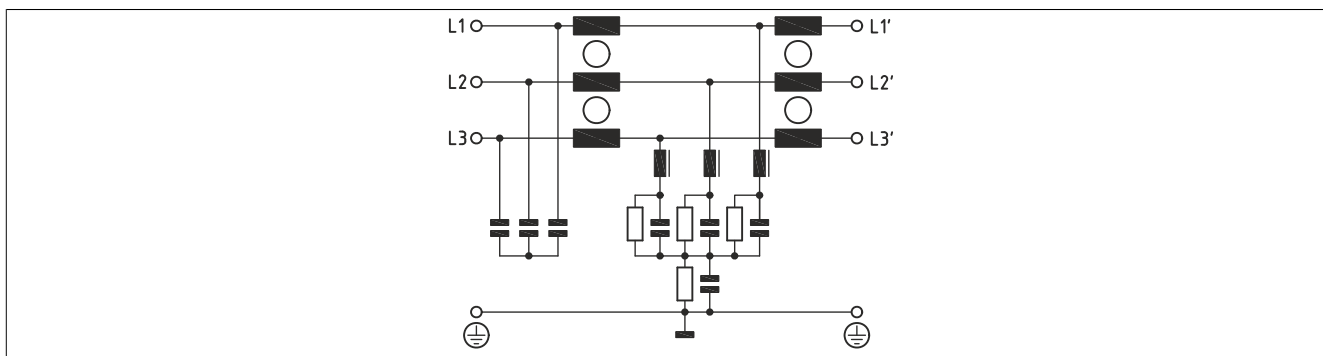

Figure 3: 8B0F - Input/Output circuit diagram