

# L70 Hardware Design

**GPS Module Series**

Rev. L70\_Hardware\_Design\_V2.2

Date: 2014-06-11



**Our aim is to provide customers with timely and comprehensive service. For any assistance, please contact our company headquarters:**

**Quectel Wireless Solutions Co., Ltd.**

Office 501, Building 13, No.99, Tianzhou Road, Shanghai, China, 200233

Tel: +86 21 5108 6236

Mail: [info@quectel.com](mailto:info@quectel.com)

**Or our local office, for more information, please visit:**

<http://www.quectel.com/support/salesupport.aspx>

**For technical support, to report documentation errors, please visit:**

<http://www.quectel.com/support/techsupport.aspx>

**GENERAL NOTES**

QUECTEL OFFERS THIS INFORMATION AS A SERVICE TO ITS CUSTOMERS. THE INFORMATION PROVIDED IS BASED UPON CUSTOMERS' REQUIREMENTS. QUECTEL MAKES EVERY EFFORT TO ENSURE THE QUALITY OF THE INFORMATION IT MAKES AVAILABLE. QUECTEL DOES NOT MAKE ANY WARRANTY AS TO THE INFORMATION CONTAINED HEREIN, AND DOES NOT ACCEPT ANY LIABILITY FOR ANY INJURY, LOSS OR DAMAGE OF ANY KIND INCURRED BY USE OF OR RELIANCE UPON THE INFORMATION. ALL INFORMATION SUPPLIED HEREIN ARE SUBJECT TO CHANGE WITHOUT PRIOR NOTICE.

**COPYRIGHT**

THIS INFORMATION CONTAINED HERE IS PROPRIETARY TECHNICAL INFORMATION OF QUECTEL CO., LTD. TRANSMITTABLE, REPRODUCTION, DISSEMINATION AND EDITING OF THIS DOCUMENT AS WELL AS UTILIZATION OF THIS CONTENTS ARE FORBIDDEN WITHOUT PERMISSION. OFFENDERS WILL BE HELD LIABLE FOR PAYMENT OF DAMAGES. ALL RIGHTS ARE RESERVED IN THE EVENT OF A PATENT GRANT OR REGISTRATION OF A UTILITY MODEL OR DESIGN.

**Copyright © Quectel Wireless Solutions Co., Ltd. 2014. All rights reserved.**

# About the Document

## History

Revision	Date	Author	Description
1.0	2012-07-10	King HAO	Initial
1.1	2012-12-21	King HAO/ Rain ZHOU	<ol style="list-style-type: none"> <li>1. Modified the current consumption of L70 module.</li> <li>2. Added the description of LOCUS function.</li> <li>3. Modified the description of standby mode.</li> <li>4. Modified the description of periodic standby mode.</li> <li>5. Modified Chapter 4: Antenna Interface.</li> <li>6. Modified the Tape and reel specification of L70 module.</li> </ol>
2.0	2013-05-16	King HAO	<ol style="list-style-type: none"> <li>1. Updated the current consumption of L70 module.</li> <li>2. Added the description of TIMER pin.</li> <li>3. Updated the description of backup mode.</li> <li>4. Added the description of periodic backup mode.</li> <li>5. Added the description of AlwaysLocate backup mode.</li> <li>6. Updated the description of LOCUS.</li> <li>7. Added the ordering information of L70 module.</li> </ol>
2.1	2014-05-10	Tony GAO	<ol style="list-style-type: none"> <li>1. Modified the input power at RF_IN.</li> <li>2. Changed the tracking sensitivity to -165dBm.</li> </ol>
2.2	2014-06-11	Tony GAO	Updated packaging information.

## Contents

About the Document.....	2
Contents.....	3
Table Index.....	5
Figure Index.....	6
<b>1 Introduction.....</b>	<b>7</b>
<b>2 Product Concept.....</b>	<b>8</b>
2.1. General Description.....	8
2.2. Key Features.....	9
2.3. Block Diagram.....	10
2.4. Evaluation Board.....	10
2.5. The Protocols Module Supports.....	11
<b>3 Application.....</b>	<b>12</b>
3.1. Pin Assignment.....	12
3.2. Pin Definition.....	12
3.3. Power Supply.....	14
3.4. Operating Modes.....	16
3.4.1. Full On Mode.....	16
3.4.2. Standby Mode.....	17
3.4.3. Backup Mode.....	18
3.4.4. Periodic Mode.....	20
3.4.5. AlwaysLocate™ Mode.....	22
3.5. Reset.....	23
3.6. UART Interface.....	24
3.7. EASY Technology.....	25
3.8. Multi-tone AIC.....	25
3.9. ANTON.....	26
3.10. LOCUS.....	26
<b>4 Antenna Interface.....</b>	<b>27</b>
4.1. Antenna Specification.....	27
4.2. Recommended Circuit for Antenna.....	27
4.2.1. Active Antenna.....	28
4.2.1.1. Active Antenna without ANTON.....	28
4.2.1.2. Active Antenna with ANTON.....	28
4.2.2. Passive Antenna.....	30
4.2.2.1. Passive Antenna without External LNA.....	30
4.2.2.2. Passive Antenna with External LNA.....	30
<b>5 Electrical, Reliability and Radio Characteristics.....</b>	<b>32</b>
5.1. Absolute Maximum Ratings.....	32
5.2. Operating Conditions.....	33

---

5.3.	Current Consumption .....	33
5.4.	Electro-static Discharge .....	34
5.5.	Reliability Test .....	34
<b>6</b>	<b>Mechanics .....</b>	<b>36</b>
6.1.	Mechanical View of the Module .....	36
6.2.	Bottom Dimension and Recommended Footprint.....	37
6.3.	Top View of the Module.....	38
6.4.	Bottom View of the Module .....	38
<b>7</b>	<b>Manufacturing .....</b>	<b>39</b>
7.1.	Assembly and Soldering .....	39
7.2.	Moisture Sensitivity .....	40
7.3.	ESD Protection.....	40
7.4.	Tape and Reel .....	40
7.5.	Ordering Information .....	41
<b>8</b>	<b>Appendix Reference .....</b>	<b>42</b>

Quectel  
Confidential

## Table Index

TABLE 1: MODULE KEY FEATURES .....	9
TABLE 2: THE PROTOCOLS SUPPORTED BY THE MODULE .....	11
TABLE 3: PIN DESCRIPTION .....	12
TABLE 4: MODULE STATES SWITCH .....	16
TABLE 5: DEFAULT CONFIGURATIONS .....	17
TABLE 6: PMTK COMMAND FORMAT .....	20
TABLE 7: RECOMMENDED ANTENNA SPECIFICATION .....	27
TABLE 8: ABSOLUTE MAXIMUM RATINGS .....	32
TABLE 9: THE MODULE POWER SUPPLY RATINGS.....	33
TABLE 10: THE MODULE CURRENT CONSUMPTION .....	33
TABLE 11: THE ESD ENDURANCE TABLE (TEMPERATURE: 25°C, HUMIDITY: 45%) .....	34
TABLE 12: RELIABILITY TEST .....	34
TABLE 13: REEL PACKING .....	41
TABLE 14: ORDERING INFORMATION .....	41
TABLE 15: RELATED DOCUMENTS .....	42
TABLE 16: TERMS AND ABBREVIATIONS .....	42

Quectel  
Confidential

## Figure Index

FIGURE 1: BLOCK DIAGRAM .....	10
FIGURE 2: PIN ASSIGNMENT .....	12
FIGURE 3: INTERNAL POWER CONSTRUCTION.....	15
FIGURE 4: POWER AND CURRENT CONSUMPTION VERSUS VCC.....	15
FIGURE 5: THE EXTERNAL SWITCH CIRCUIT FOR TIMER .....	18
FIGURE 6: RTC SUPPLY FROM NON-CHARGEABLE BATTERY .....	19
FIGURE 7: REFERENCE CHARGING CIRCUIT FOR CHARGEABLE BATTERY.....	19
FIGURE 8: SEIKO MS920SE CHARGE AND DISCHARGE CHARACTERISTICS .....	20
FIGURE 9: PERIODIC MODE .....	21
FIGURE 10: ALWAYSLOCATE™ MODE .....	22
FIGURE 11: REFERENCE RESET CIRCUIT USING OC CIRCUIT.....	23
FIGURE 12: RESTART TIMING .....	23
FIGURE 13: CONNECTION OF SERIAL INTERFACES .....	24
FIGURE 14: RS-232 LEVEL SHIFT CIRCUIT.....	25
FIGURE 15: REFERENCE DESIGN WITH ACTIVE ANTENNA.....	28
FIGURE 16: REFERENCE DESIGN FOR ACTIVE ANTENNA WITH ANTON.....	29
FIGURE 17: REFERENCE DESIGN WITH PASSIVE ANTENNA .....	30
FIGURE 18: REFERENCE DESIGN FOR PASSIVE ANTENNA WITH LNA.....	31
FIGURE 19: TOP VIEW AND SIDE VIEW (UNIT: MM).....	36
FIGURE 20: BOTTOM DIMENSION (UNIT: MM).....	37
FIGURE 21: FOOTPRINT OF RECOMMENDATION (UNIT: MM).....	37
FIGURE 22: TOP VIEW OF THE MODULE .....	38
FIGURE 23: BOTTOM VIEW OF THE MODULE .....	38
FIGURE 24: RAMP-SOAK-SPIKE-REFLOW OF FURNACE TEMPERATURE .....	39
FIGURE 25: TAPE AND REEL SPECIFICATION.....	40

# 1 Introduction

This document defines and specifies L70 GPS module. It describes L70 module hardware interfaces and its external application reference circuits, mechanical size and air interface.

This document can help you quickly understand the interface specifications, electrical and mechanical details of L70 module. We also offer you other documents such as L70 software application notes and user guider. These documents can ensure you use L70 module to design and set up applications quickly.

Quectel  
Confidential



## 2 Product Concept

### 2.1. General Description

The L70 GPS module brings the high performance of MTK positioning engine to the industrial applications. It is able to achieve the industry's highest level of sensitivity, accuracy and TTFF with the lowest power consumption in a small-footprint lead-free package. With 66 search channels and 22 simultaneous tracking channels, it acquires and tracks satellites in the shortest time even at indoor signal level. The embedded flash memory provides capacity for users to store some useful navigation data and allows for future updates.

L70 module combines with many advanced features including EASY, AIC, LOCUS and AlwaysLocate™. These features are beneficial to save consumption, accelerate TTFF, and improve sensitivity for GPS system. The module supports various location, navigation and industrial applications including autonomous GPS, SBAS (including WAAS, EGNOS, MSAS, and GAGAN), QZSS, and AGPS.

EASY technology as the key feature of L70 is one kind of AGPS. Collecting and processing all internal aiding information like GPS time, Ephemeris, Last Position etc, the GPS module will have a fast TTFF in either Hot or Warm start.

L70 module is an SMD type module with the compact 10.1mm × 9.7mm × 2.5mm form factor, which can be embedded in your applications through the 18-pin pads. It provides necessary hardware interfaces between the module and the main board.

The module is fully ROHS compliant to EU regulation.

## 2.2. Key Features

**Table 1: Module Key Features**

Feature	Implementation
Power Supply	<ul style="list-style-type: none"> <li>● Supply voltage: 2.8V~4.3V typical: 3.3V</li> </ul>
Power Consumption	<ul style="list-style-type: none"> <li>● Acquisition: 18mA @VCC=3.3V</li> <li>● Tracking: 12mA @VCC=3.3V</li> <li>● Standby: 200uA @VCC=3.3V</li> <li>● Backup: 7uA @V_BCKP=3.3V</li> </ul>
Receiver Type	<ul style="list-style-type: none"> <li>● GPS L1 1575.42MHz C/A Code</li> <li>● 66 search channels, 22 simultaneous tracking channels</li> </ul>
Sensitivity	<ul style="list-style-type: none"> <li>● Acquisition: -148dBm</li> <li>● Re-acquisition: -160dBm</li> <li>● Tracking: -165dBm</li> </ul>
TTFB (EASY Enabled)	<ul style="list-style-type: none"> <li>● Cold start: 15s typ. @-130dBm</li> <li>● Warm start: 5s typ. @-130dBm</li> <li>● Hot start: 1s typ. @-130dBm</li> </ul>
TTFB (EASY Disabled)	<ul style="list-style-type: none"> <li>● Cold start (Autonomous): 35s typ. @-130dBm</li> <li>● Warm start (Autonomous): 30s typ. @-130dBm</li> <li>● Hot start (Autonomous): 1s typ. @-130dBm</li> </ul>
Horizontal Position Accuracy (Autonomous)	<ul style="list-style-type: none"> <li>● &lt;2.5m CEP@-130dBm</li> </ul>
Max Update Rate	<ul style="list-style-type: none"> <li>● Up to 10Hz, 1Hz by default</li> </ul>
Accuracy of 1PPS Signal	<ul style="list-style-type: none"> <li>● Typical accuracy &lt;15ns (Time service is not supported)</li> <li>● Time pulse width 100ms</li> </ul>
Velocity Accuracy	<ul style="list-style-type: none"> <li>● Without aid: 0.1m/s</li> </ul>
Acceleration Accuracy	<ul style="list-style-type: none"> <li>● Without aid: 0.1m/s<sup>2</sup></li> </ul>
Dynamic Performance	<ul style="list-style-type: none"> <li>● Maximum altitude: 18,000m</li> <li>● Maximum velocity: 515m/s Maximum</li> <li>● Acceleration: 4G</li> </ul>
UART Port	<ul style="list-style-type: none"> <li>● UART port: TXD1 and RXD1</li> <li>● Supports baud rate from 4800bps to 115200bps,9600bps by default</li> <li>● UART port is used for NMEA output, MTK proprietary commands input and firmware upgrade</li> </ul>
Temperature Range	<ul style="list-style-type: none"> <li>● Normal operation: -40°C ~ +85°C</li> <li>● Storage temperature: -45°C ~ +125°C</li> </ul>
Physical Characteristics	<ul style="list-style-type: none"> <li>● Size: 10.1±0.15 × 9.7±0.15 × 2.5±0.15mm</li> <li>● Weight: Approx. 0.6g</li> </ul>

**NOTES**

1. The power consumption is measured under GPS signal generator and EASY, AIC and SBAS are enabled.
2. The sensitivity is measured with passive antenna but without external LNA. It might be higher by about 2dB with external LNA or only with active antenna.

### 2.3. Block Diagram

The following figure shows a block diagram of L70 module. It consists of a single chip GPS IC which includes RF part and Baseband part, a SAW filter, a TCXO and a crystal oscillator.

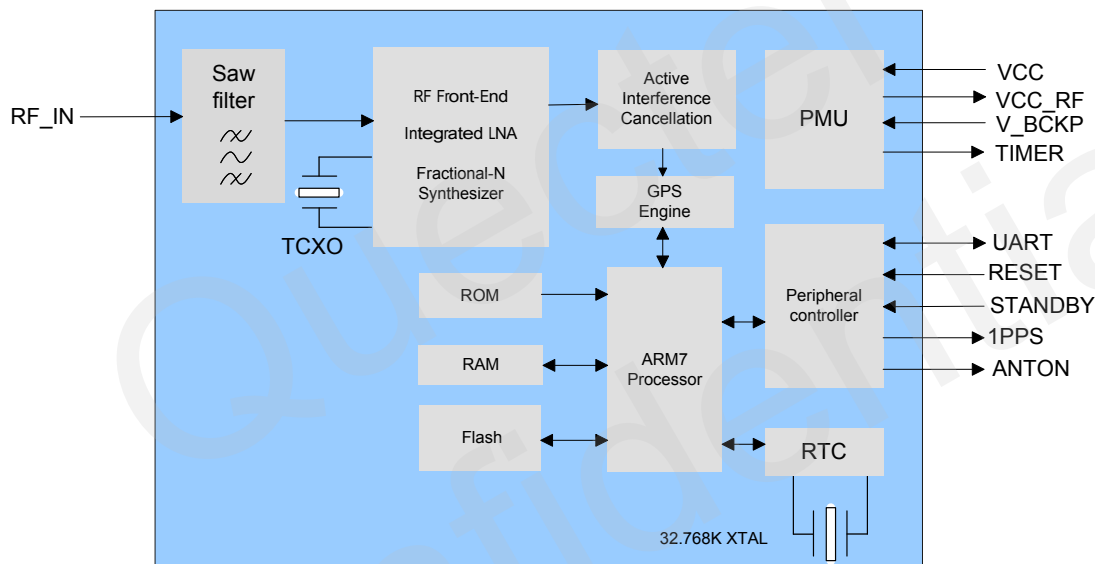

**Figure 1: Block Diagram**

### 2.4. Evaluation Board

In order to help you use L70 module on your applications, Quectel supplies an Evaluation Board (EVB) with micro USB serial cable, active antenna and other peripherals to test the module.

For more details, please refer to the **document [1]**.

## 2.5. The Protocols Module Supports

Table 2: The Protocols Supported by the Module

Protocol	Type
NMEA	Output, ASCII, 0183, 3.01
PMTK	Input, MTK proprietary protocol

**NOTE**

Please refer to **document [2]** about NMEA standard protocol and MTK proprietary protocol.

Quectel  
Confidential

# 3 Application

The L70 module is equipped with an 18-pin 1.1mm pitch SMT pad that connects to your application platform. Sub-interfaces included in these pads are described in details in the following chapters.

## 3.1. Pin Assignment



Figure 2: Pin Assignment

## 3.2. Pin Definition

Table 3: Pin Description

Power Supply					
Pin Name	Pin No.	I/O	Description	DC Characteristics	Comment
VCC	8	I	Main power supply	Vmax=4.3V Vmin=2.8V Vnom=3.3V	Supply current of no less than 100mA.
V_BCKP	6	I	Backup power supply	Vmax=4.5V Vmin=1.5V	Supply power for RTC domain when VCC is

				Vnom=3.3V	powered off.
VCC_RF	14	O	Power supply for external RF components	Vmax=4.3V Vmin=2.8V Vnom=3.3V	Usually supply power for external active antenna or LNA. If unused, keep this pin open. VCC_RF ≈ VCC

### Reset

Pin Name	Pin No.	I/O	Description	DC Characteristics	Comment
RESET	9	I	System reset	VILmin=-0.3V VILmax=0.8V VIHmin=2.0V VIHmax=3.6V	Low level active. If unused, keep this pin open or connect it to VCC.

### UART Port

Pin Name	Pin No.	I/O	Description	DC Characteristics	Comment
RXD1	3	I	Receive data	VILmin=-0.3V VILmax=0.8V VIHmin=2.0V VIHmax= 3.6V	
TXD1	2	O	Transmit data	VOLmin=-0.3V VOLmax=0.4V VOHmin=2.4V VOHmax=3.1V	

### RF Interface

Pin Name	Pin No.	I/O	Description	DC Characteristics	Comment
RF_IN	11	I	RF signal input	Characteristic impedance of 50Ω	Refer to <b>chapter 4</b>

### Other Interfaces

Pin Name	Pin No.	I/O	Description	DC Characteristics	Comment
ANTON	13	O	External LNA control pin or active antenna power control pin in power saving mode	The typical value is 2.8V in full on mode and will be pulled down in power saving mode	If unused, keep this pin open.
STANDBY	5	I	Used to enter into or exit from standby mode	VILmin=-0.3V VILmax=0.8V VIHmin=2.0V VIHmax=3.6V	Pulled up internally. It is edge-triggered. If unused, keep this pin open.

1PPS	4	O	One pulse per second	VOLmin=-0.3V VOLmax=0.4V VOHmin=2.4V VOHmax=3.1V	Synchronized at rising edge, the pulse width is 100ms. If unused, keep this pin open.
TIMER	18	O	An open drain output signal can be used to control GPS module main power on/off	VOLmin=-0.3V VOLmax=0.4V VOHmin=2.4V VOHmax=3.1V	It belongs to RTC domain. If unused, keep this pin open or connect to Ground externally.
RESERVED	16,17				Keep these pins open.

### 3.3. Power Supply

VCC pin supplies power for BB, RF, I/O and RTC domain. The load current of VCC varies according to the VCC level, processor load, the number of satellites is tracking and the rate of satellite re-acquisition. Typical VCC peak current may reach to 30mA during GPS acquisition after power up. So it is important to supply sufficient current and make the power clean and stable. VCC supply ripple voltage should meet the requirement: 54mV (RMS) max @f=0...3MHz and 15mV (RMS) max @ f >3MHz. You should choose the LDO without built-in output high-speed discharge function to keep long output voltage drop-down period. The decouple combination of 10uF and 100nF capacitor is recommended nearby VCC pin.

The V\_BCKP pin supplies power for RTC domain. A cell battery with the combination of 4.7uF and 100nF capacitor is recommended nearby V\_BCKP pin. The voltage of RTC domain ranges from 1.5V to 4.5V. In order to achieve a better TTFF, RTC domain should be valid all the time. It can supply power for SRAM memory in RTC domain which contains all the necessary GPS information for quick start-up and a small amount of user configuration variables.

The module's internal power construction is shown as below.

VCC not only supplies power for PMU but also for VCC\_RF and RTC domain. V\_BCKP supplies power for RTC domain only. The two diodes form an "OR" gate supply power for RTC domain. TIMER signal belongs to RTC domain, which has been highlighted as red line in the following figure can be used to control the power switch on/off. For more details about TIMER function, please refer to **chapter 3.4.3**.

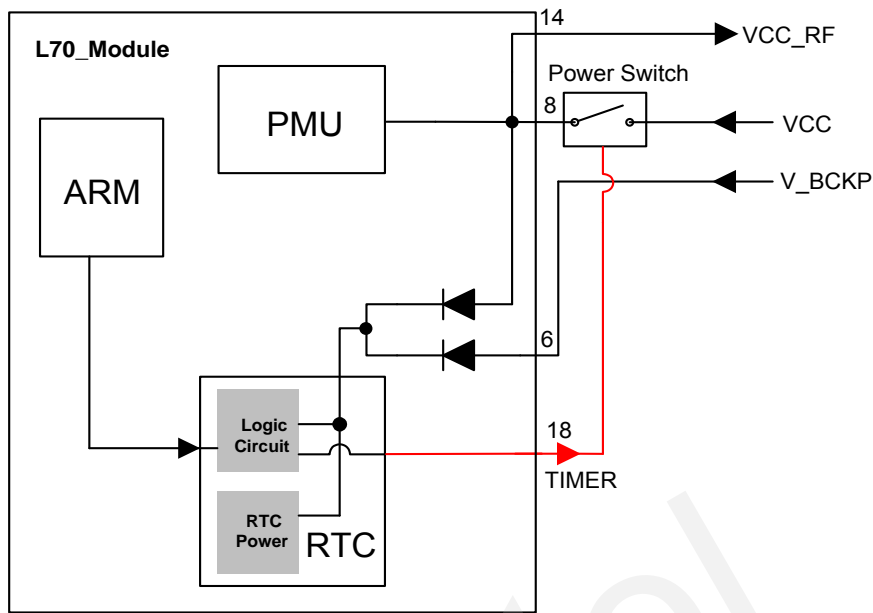

Figure 3: Internal Power Construction

The following picture shows the average power and current consumption versus VCC supply voltage. It was measured with GPS signal generator in tracking mode.

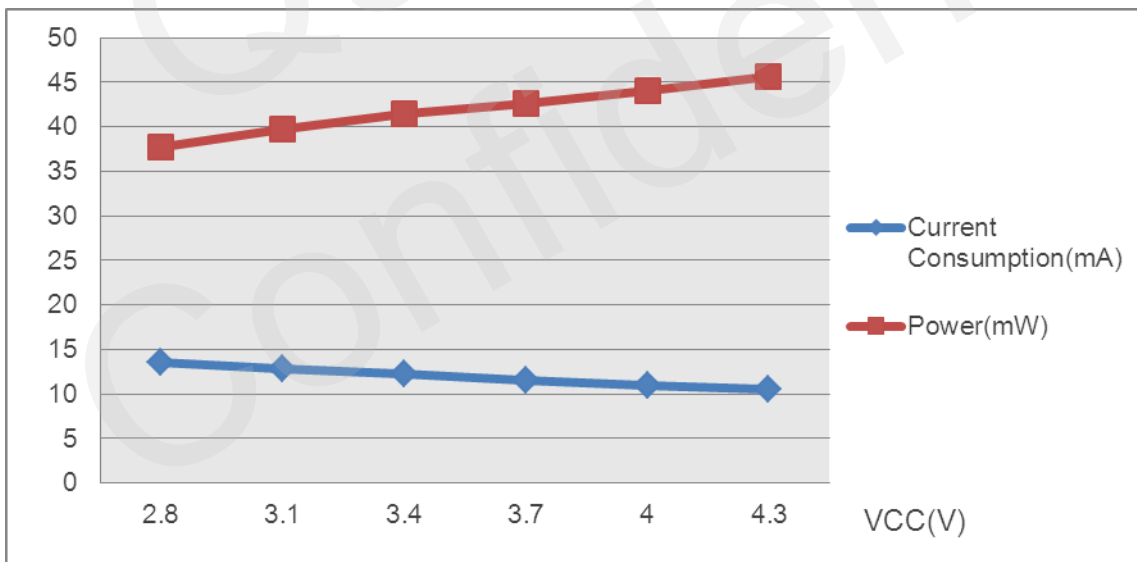

Figure 4: Power and Current Consumption versus VCC



### 3.4. Operating Modes

The table below briefly illustrates the relationship among different operating modes of L70 module.

**Table 4: Module States Switch**

Current Mode	Next Mode				
	Backup	Standby	Full on	Periodic	AlwaysLocate
Backup	N/A	N/A	Refer to <b>chapter 3.4.3</b>	N/A	N/A
Standby	N/A	N/A	<ul style="list-style-type: none"> <li>● Pull STANDBY pin high</li> <li>● Send any data via UART1</li> </ul>	N/A	N/A
Full on	Refer to <b>chapter 3.4.3</b>	<ul style="list-style-type: none"> <li>● Pull STANDBY pin low</li> <li>● PMTK161</li> </ul>	N/A	PMTK225	PMTK225
Periodic	N/A	N/A	Refer to <b>chapter 3.4.4</b>	N/A	N/A
Always Locate	N/A	N/A	Refer to <b>chapter 3.4.5</b>	N/A	N/A

**NOTE**

Please refer to **document [2]** about MTK proprietary protocol for more details.

#### 3.4.1. Full On Mode

Full on mode includes tracking mode and acquisition mode. Acquisition mode is defined as the module starts to search satellites, determine visible satellites and coarse carrier frequency and code phase of satellite signals. When the acquisition is completed, it switches to tracking mode automatically. Tracking mode is defined as the module keeps tracking satellites and demodulates the navigation data from the specific satellites.

Whether the combination of VCC and V\_BCKP is valid or only VCC is valid, the module will enter into full on mode automatically and follow the default configurations as below. You can refer to **chapter 3.3** about internal power construction to have a good comprehension. You also can use PMTK commands to change the configurations to satisfy your requirements.

**Table 5: Default Configurations**

Item	Configuration	Comment
Baud Rate	9600bps	
Protocol	NMEA	RMC, VTG, GGA, GSA, GSV and GLL
Update Rate	1Hz	
SBAS	Enable	
AIC	Enable	
LOCUS	Disable	
EASY	Enable	EASY will be disabled automatically when update rate exceeds 1Hz.

### 3.4.2. Standby Mode

Standby mode is a low-power mode. In standby mode, the internal core and I/O power domain are still active, but RF and TCXO are powered off, the module stops satellites search and navigation. UART1 is still accessible like PMTK commands or any other data, but there is no NMEA messages output.

There are two ways to enter into standby mode and exit from standby mode.

- **Using PMTK command:** Sending PMTK command "\$PMTK161,0\*28" will make L70 module enter into standby mode. Sending any data via UART1 can wake the module up. When the module exit from standby mode, it will use all internal aiding information like GPS time, Ephemeris, Last Position etc, resulting to a fastest possible TTFF in either Hot or Warm start. The typical standby current consumption in this way is about 200uA @VCC=3.3V.
- **Using STANDBY pin:** Pulling STANDBY pin low also can make L70 module enter into standby mode and releasing STANDBY which has been pulled high internally will make the module back to full on mode. Note that pulling down STANDBY pin to ground will cause the extra current consumption which makes the typical standby current reach to about 280uA @VCC=3.3V.

#### NOTE

Setting the host's GPIO which control STANDBY pin as input is recommended before turning on the module to avoid entering into standby mode unexpectedly during starting the module due to its edge-triggered characteristic, after that, you can reset the GPIO as output to control the STANDBY pin. If unused, keep this pin open.

### 3.4.3. Backup Mode

Backup mode is a lower power mode than standby mode. In this mode, only the backup supply V\_BCKP is powered on while the main supply VCC is switched off by host or the TIMER signal of L70. In order to enter into backup mode autonomously via the TIMER pin, an external switch circuit is necessary. The following figure has shown a typical reference design about the switch circuit for TIMER.

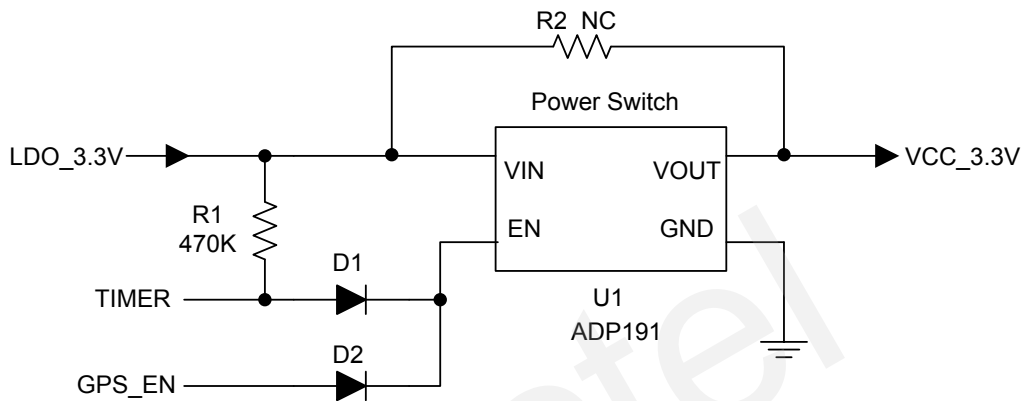

Figure 5: The External Switch Circuit for TIMER

#### NOTES

1. U1 is an integrated power switch component. The part number ADP191 is recommended. U1 also can be replaced by discrete components, please refer to **document [3]** for more details.
2. TIMER pin also can be used to control the EN pin of a LDO, please refer to **document [3]** for more details.
3. TIMER and GPS\_EN signals form an “OR” logic via the Schottky diodes D1 and D2. GPS\_EN is a GPIO signal comes from the host.
4. TIMER is an open drain output signal. When TIMER pin is used, please pull it high by using an external resistor. R1 is the pull-up resistor for TIMER signal.
5. U1, R1, D1 and D2 can be omitted by mounting R2 with 0R. In this case, TIMER function is disabled.

Keeping GPS\_EN signal low and sending PMTK command “\$PMTK225, 4\*2F” will make L70 module enter into backup mode forever. When this command is executed successfully, TIMER signal will be pulled down to close the power switch, so L70 module can go into backup mode as the main power VCC is cut off. For this case, pulling the GPS\_EN signal high by host is the only way to wake the module up.

In backup mode, L70 module stops to acquire and track satellites. UART1 is not accessible. But the backed-up memory in RTC domain which contains all the necessary GPS information for quick start-up and a small amount of user configuration variables is alive. Due to the backed-up memory, EASY technology is available. The typical consumption in backup mode can be low as 7uA.

The V\_BCKP pin can be directly supplied by an external capacitor or battery (rechargeable or non-chargeable). Please refer to the following figures for RTC backup reference design.

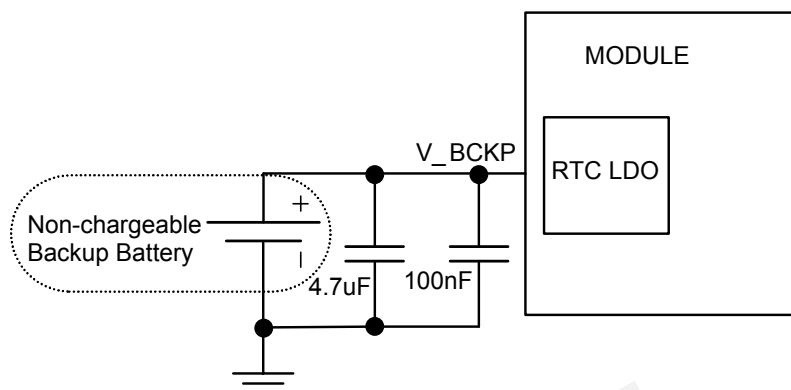

**Figure 6: RTC Supply from Non-chargeable Battery**

The V\_BCKP pin does not support charging function for rechargeable battery. It is necessary to add an external charging circuit for rechargeable battery.

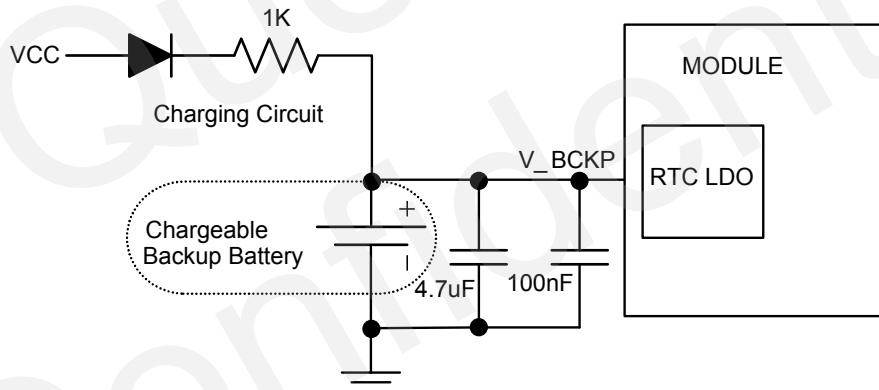

**Figure 7: Reference Charging Circuit for Chargeable Battery**

Coin-type Rechargeable Capacitor such as MS920SE from Seiko can be used and Schottky diode such as RB520S30T1G from ON Semiconductor is recommended to be used here for its low voltage drop.

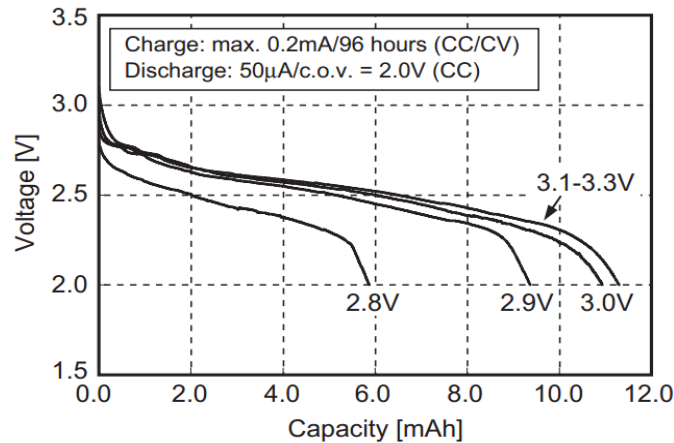

Figure 8: Seiko MS920SE Charge and Discharge Characteristics

### 3.4.4. Periodic Mode

Periodic mode is a power saving mode of L70 that can control the full on mode and standby/backup mode periodically to reduce power consumption. It contains periodic standby mode and periodic backup mode.

The format of the command which enters into periodic mode is as follows:

Table 6: PMTK Command Format

Parameter	Format	Description
<b>Format:</b> \$PMTK225,<Type>,<Run_time>,<Sleep_time>,<2nd_run_time>,<2nd_sleep_time>*<checksum> <CR><LF>		
Type	Decimal	<b>Type=1</b> for Periodic Backup Mode <b>Type=2</b> for Periodic Standby Mode
Run_time	Decimal	Full on period (ms)
Sleep_time	Decimal	Standby/Backup period (ms)
2nd_run_time	Decimal	Full on period (ms) for extended acquisition in case GPS module acquisition fails during the <b>Run_time</b>
2nd_sleep_time	Decimal	Standby/Backup period (ms) for extended sleep in case GPS module acquisition fails during the <b>Run_time</b>
Checksum	Hexadecimal	Hexadecimal checksum
<b>Example:</b> \$PMTK225,1,3000,12000,18000,72000*16<CR><LF> \$PMTK225,2,3000,12000,18000,72000*15<CR><LF>		

Sending "\$PMTK225,0\*2B" in any time will make the module to full on mode from periodic standby mode. Sending "\$PMTK225,0\*2B" just in **Run\_time** or **2nd\_run\_time** can make the module to full on mode from periodic backup mode.

**NOTES**

1. Periodic backup mode needs the external switch circuit to support, please refer to **chapter 3.4.3**.
2. Before entering into periodic backup mode, please ensure the GPS\_EN signal is low and power supply for V\_BCKP is alive.

The following figure has shown the operation of periodic mode. When you send PMTK command, the module will be in the full on mode firstly. After several minutes, the module will enter into the periodic mode and follow the parameters set by you. When the module fails to fix the position in **run time**, the module will switch to **2nd\_run\_time** and **2nd\_sleep\_time** automatically. As long as the module fixes the position again, the module will return to **Run\_time** and **Sleep\_time**.

Please ensure the module is in the tracking state before entering into periodic mode. Otherwise the module will have a risk of failure to track the satellites. If GPS module is located in weak signal environment, it is better to set the longer **2nd\_run\_time** to ensure the success of re-acquisition.

The average current value can be calculated by the following formula:

$$I_{\text{periodic}} = (I_{\text{tracking}} * T1 + I_{\text{standby/backup}} * T2) / (T1 + T2) \quad T1: \text{Run\_time}, T2: \text{Sleep\_time}$$

Example:

PMTK225,2,3000,12000,18000,72000\*15 for periodic mode with 3s in tracking mode and 12s in standby mode. The average current consumption is calculated below:

$$I_{\text{periodic}} = (I_{\text{tracking}} * T1 + I_{\text{standby}} * T2) / (T1 + T2) = (12\text{mA} * 3\text{s} + 0.2\text{mA} * 12\text{s}) / (3\text{s} + 12\text{s}) \approx 2.6 \text{ (mA)}$$

PMTK225,1,3000,12000,18000,72000\*16 for periodic mode with 3s in tracking mode and 12s in backup mode. The average current consumption is calculated below:

$$I_{\text{periodic}} = (I_{\text{tracking}} * T1 + I_{\text{backup}} * T2) / (T1 + T2) = (12\text{mA} * 3\text{s} + 0.007\text{mA} * 12\text{s}) / (3\text{s} + 12\text{s}) \approx 2.4 \text{ (mA)}$$

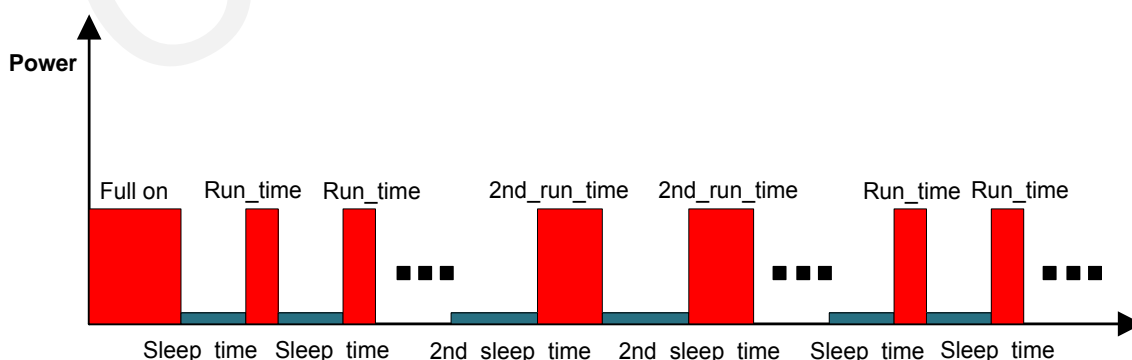

Figure 9: Periodic Mode

### 3.4.5. AlwaysLocate™ Mode

AlwaysLocate™ is an intelligent power saving mode. It contains AlwaysLocate™ backup mode and AlwaysLocate™ standby mode.

AlwaysLocate™ standby mode supports the module to switch automatically between full on mode and standby mode. According to the environmental and motion conditions, the module can adaptively adjust the full on time and standby time to achieve a balance between positioning accuracy and power consumption. Sending "\$PMTK225,8\*23" and the module returning: "\$PMTK001,225,3\*35" means the module accesses AlwaysLocate™ standby mode successfully. It will benefit power saving in this mode. Sending "\$PMTK225,0\*2B" in any time will make the module back to full on mode.

AlwaysLocate™ backup mode is similar to AlwaysLocate™ standby mode. The difference is that AlwaysLocate™ backup mode switches automatically between full on mode and backup mode. The PMTK command to enter into AlwaysLocate™ backup mode is "\$PMTK225,9\*22". The module can exit from AlwaysLocate™ backup mode by command "\$PMTK225,0\*2B" sent just after the module has been waked up from previous backup cycle.

The positioning accuracy in AlwaysLocate™ mode will be somewhat degraded, especially in high speed. The following picture shows the rough power consumption of L70 module in different daily scenes when AlwaysLocate™ mode is enabled.

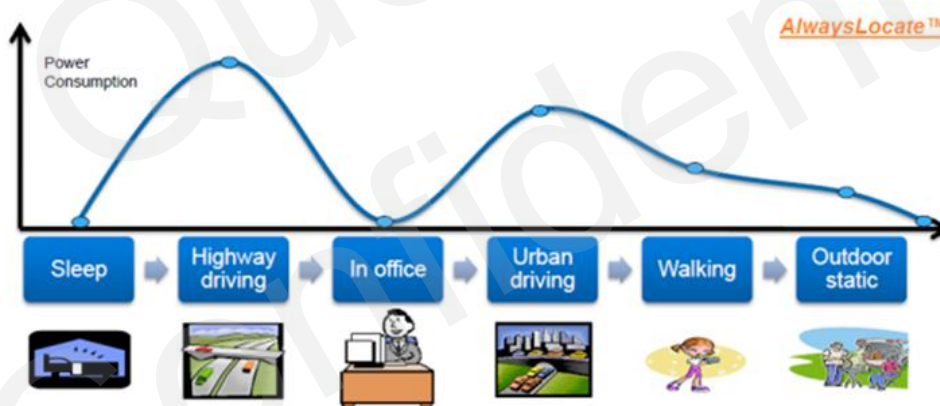

Figure 10: AlwaysLocate™ Mode

Example:

The typical average consumption is about 1.5mA in AlwaysLocate™ standby mode and 1.4mA in AlwaysLocate™ backup mode.

#### NOTES

1. Power consumption is measured under outdoor static mode with active antenna.
2. The same as periodic backup mode, AlwaysLocate™ backup mode also needs the external switch circuit to support, please refer to **chapter 3.4.3**.

- Before entering into periodic backup mode, please ensure the GPS\_EN signal is low and power supply for V\_BCKP is alive.

### 3.5. Reset

L70 module can be restarted by driving the RESET to a low level voltage for a certain time and then releasing it. This operation will reset the digital part of the GPS receiver. Note that Non-Volatile Backup RAM content is not cleared and thus fast TTFB is possible. An OC driver circuit shown as below is recommended to control the RESET.

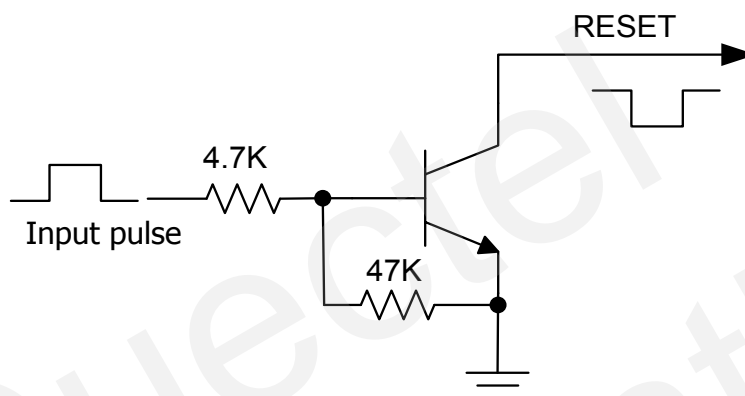

Figure 11: Reference Reset Circuit Using OC Circuit

The restart timing of L70 has been illustrated below.

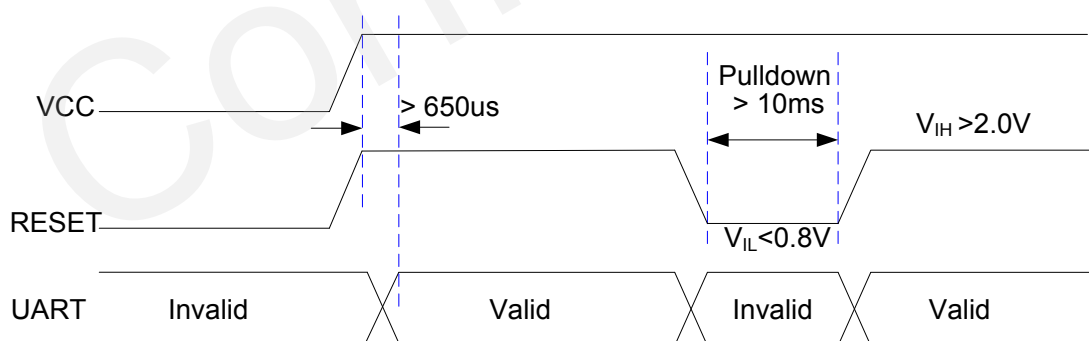

Figure 12: Restart Timing



### 3.6. UART Interface

The module provides one universal asynchronous receiver & transmitter serial port. The module is designed as a DCE (Data Communication Equipment), following the traditional DCE-DTE (Data Terminal Equipment) connection. The module and the client (DTE) are connected through the following signals shown as Figure 13. It supports data baud-rate from 4800bps to 115200bps.

UART port:

- TXD1: Send data to the RXD signal line of DTE
- RXD1: Receive data from the TXD signal line of DTE

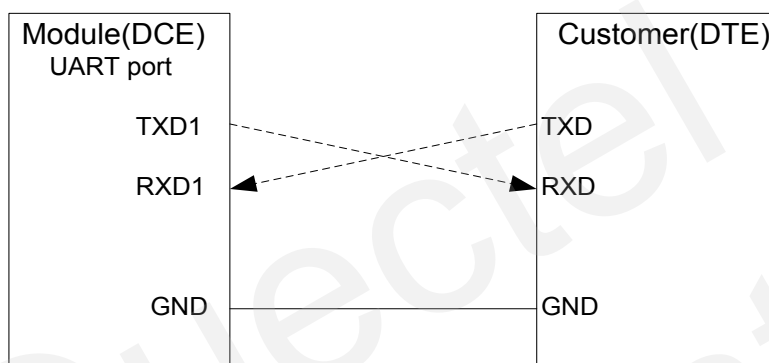
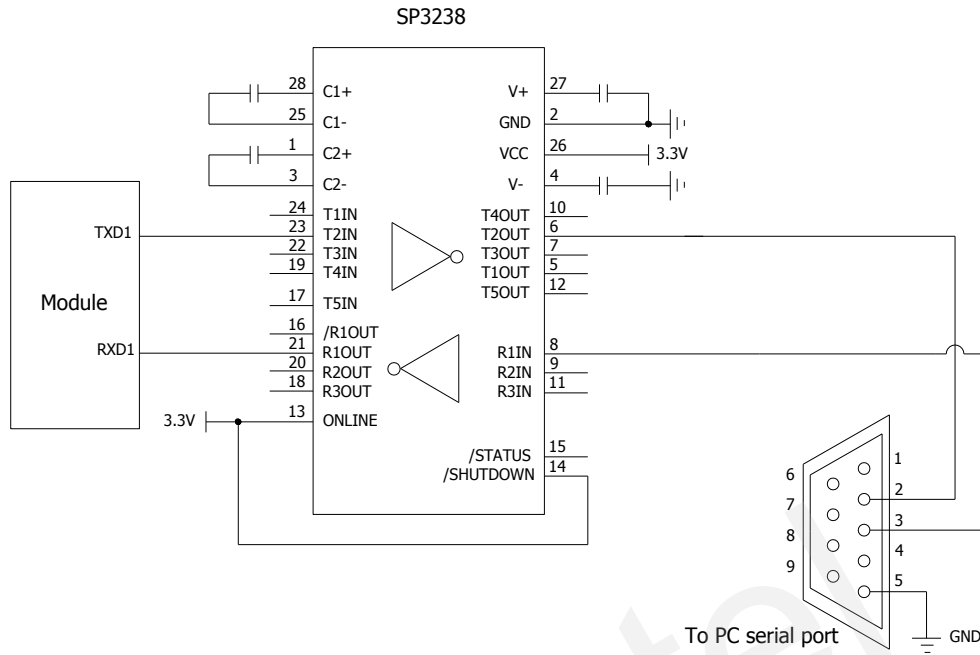

**Figure 13: Connection of Serial Interfaces**

This UART port has the following features:

- UART port can be used for firmware upgrade, NMEA output and PMTK proprietary commands input.
- The default output NMEA type setting is **RMC, VTG, GGA, GSA, GSV and GLL**.
- UART port supports the following data rates:  
4800, 9600, 14400, 19200, 38400, 57600, 115200.  
**The default setting is 9600bps, 8 bits, no parity bit, 1 stop bit.**
- Hardware flow control and synchronous operation are not supported.

The UART port does not support the RS-232 level but only CMOS level. If the module's UART port is connected to the UART port of a computer, it is necessary to add a level shift circuit between the module and the computer. Please refer to the following figure.



**Figure 14: RS-232 Level Shift Circuit**

### 3.7. EASY Technology

EASY technology works as embedded software which can accelerate TTFF by predicting satellite navigation messages from received ephemeris. The GPS engine will calculate and predict orbit information automatically up to 3 days after first receiving the broadcast ephemeris, and saving the predicted information into the internal memory. GPS engine will use this information for positioning if no enough information from satellites, so the function will be helpful for positioning and TTFF improvement.

The EASY function can reduce TTFF to 5s for warm start. In this case, RTC domain should be valid. In order to gain enough broadcast ephemeris information from GPS satellites, the GPS module should receive the information for at least 5 minutes in a good signal condition after fixing the position.

EASY function is enabled by default. The command "\$PMTK869,1,0\*34" can be used to disable EASY. For more details, please refer to the **document [2]**.

### 3.8. Multi-tone AIC

L70 module provides an advanced technology called multi-tone AIC (Active Interference Cancellation) to reject RF interference which comes from other active components on the main board.

Up to 12 multi-tone AIC embedded in the module can provide effective narrow-band interference and jamming elimination. The GPS signal could be recovered from the jammed signal, which can ensure better navigation quality. AIC is enabled by default, closing it will save about 1mA @VCC=3.3V consumption. The following commands can be used to set AIC.

Enable AIC function: "\$PMTK 286,1\*23".

Disable AIC function: "\$PMTK 286,0\*22".

### 3.9. ANTON

L70 module provides a pin called ANTON which is related to module states. Its voltage level will be changed in different module states. When the module works in full on mode, this pin is a high level, while works in standby mode, backup mode as well as sleep time in periodic mode and AlwaysLocate™ mode, this pin is a low level. Based on this characteristic, ANTON pin can be used to control the power supply of active antenna or the enable pin of an external LNA to save power consumption. There is an example of this pin's application described in **chapter 4.2**.

### 3.10. LOCUS

L70 module supports the embedded logger function called LOCUS. It can log position information to the internal flash memory automatically when this function is enabled by sending PMTK command "\$PMTK185, 0\*22". Due to this function, the host can go to sleep to save power consumption and do not need to receive the NMEA information all the time. The module can provide a log capacity of more than 16 hours.

The detail procedures of this function are illustrated bellow:

- The module has fixed the position (only 3D\_fixed is available);
- Sending PMTK command "\$PMTK184,1\*22" to erase internal flash;
- Sending PMTK command "\$PMTK185,0\*22" to start log;
- Module logs the basic information (UTC time, latitude, longitude and height) every 15 seconds to internal flash memory;
- Stop logging the information by sending "\$PMTK185,1\*23";
- Host can get the data from the module via UART1 by sending "\$PMTK622,1\*29".

The raw data which host gets has to be parsed via LOCUS parser code provided by Quectel. For more details, please contact Quectel's technical support team.

# 4 Antenna Interface

L70 module receives L1 band signal from GPS satellites at a nominal frequency of 1575.42MHz. The RF signal is obtained from the RF\_IN pin. The impedance of RF trace line in main PCB should be controlled by 50 Ohm, and the length should be kept as short as possible.

## 4.1. Antenna Specification

Table 7: Recommended Antenna Specification

Antenna Type	Specification
Passive Antenna	Center frequency: 1575.42MHz Band width: >5MHZ VSWR: <2 (Typ.) Polarization: RHCP or Linear Gain: >0dBi
Active Antenna	Center frequency: 1575.42MHz Band width: >5MHZ VSWR: <2 (Typ.) Polarization: RHCP or Linear Noise figure: <1.5dB Gain (antenna): >-2dBi Gain (embedded LNA): 20dB (Typ.) Total gain: >18dBi (Typ.)

## 4.2. Recommended Circuit for Antenna

Both active and passive antenna can be used for L70 module.

## 4.2.1. Active Antenna

### 4.2.1.1. Active Antenna without ANTON

The following figure is a typical reference design with active antenna. In this mode, the antenna directly power from the VCC\_RF.

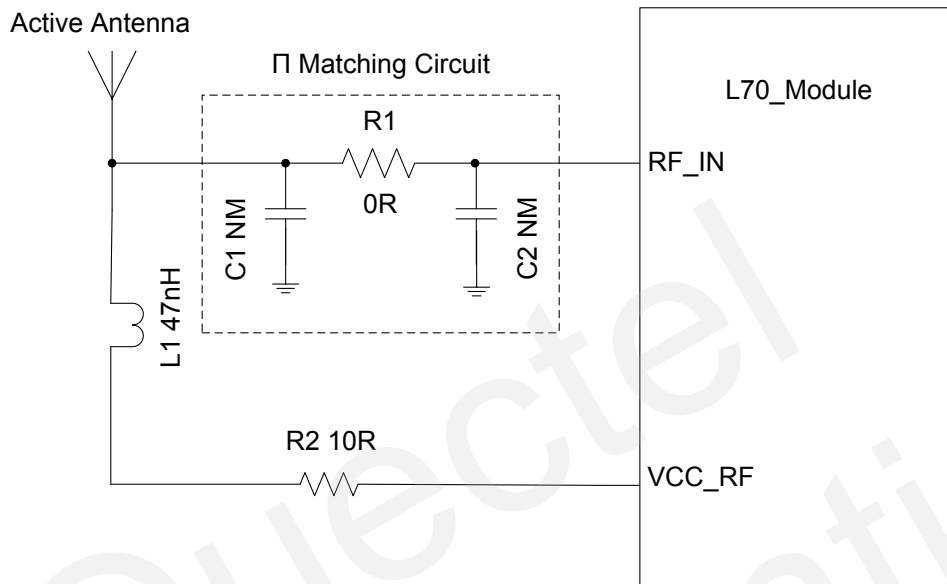

**Figure 15: Reference Design with Active Antenna**

C1, R1, C2 are reserved matching circuit for antenna impedance modification. By default, C1 and C2 are not mounted, R1 is 0 ohm.

L70 module provides power supply for external active antenna by VCC\_RF. The voltage ranges from 2.8V to 4.3V, typical value is 3.3V. If the VCC\_RF voltage does not meet the requirement for powering the active antenna, an external LDO should be used.

The inductor L1 is used to prevent the RF signal from leaking into the VCC\_RF and route the bias supply to the active antenna and the recommended value of L1 is no less than 47nH. R2 can protect the whole circuit in case the active antenna is shorted to ground.

### 4.2.1.2. Active Antenna with ANTON

L70 module can also save power consumption by controlling the power supply of active antenna through the pin "ANTON".

The reference circuit for active antenna with "ANTON" function is given as below.

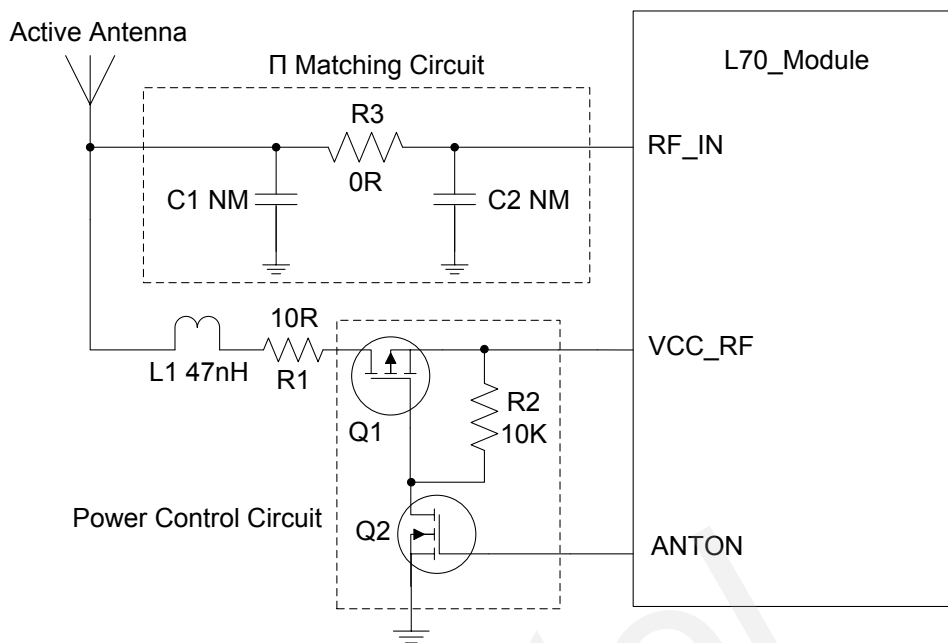

**Figure 16: Reference Design for Active Antenna with ANTON**

ANTON is an optional pin which can be used to control the power supply of the active antenna. When the ANTON pin is pulled down, MOSFET Q1 and Q2 are in high impedance state and the power supply for antenna is cut off. When ANTON is pulled high, it will make Q1 and Q2 in the on-state, VCC\_RF will provide power supply for the active antenna. The high and low level of ANTON signal is determined by the module's states. Please refer to **chapter 3.9** for more details. If unused, please keep this pin open.

For minimizing the current consumption, the value of resistor R2 should not be too small, and the recommended value is 10k ohm.

## 4.2.2. Passive Antenna

### 4.2.2.1. Passive Antenna without External LNA

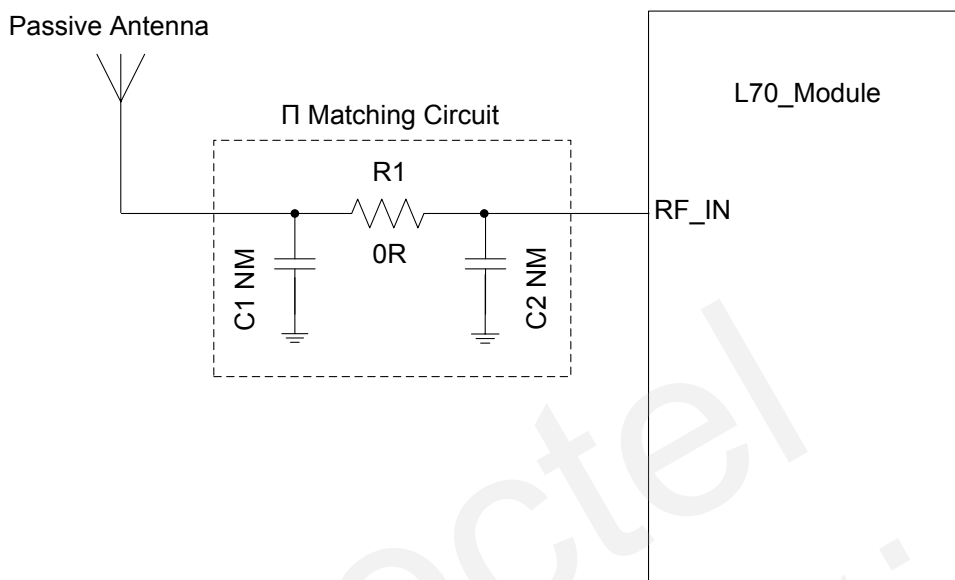

**Figure 17: Reference Design with Passive Antenna**

The above figure is a typical reference design with passive antenna.

C1, R1, C2 are reserved matching circuit for antenna impedance modification. By default, C1 and C2 are not mounted, R1 is 0 ohm. Impedance of RF trace should be controlled by 50 ohm and the length should be kept as short as possible.

If an external LNA is added between passive antenna and L70 module, the total sensitivity will be improved about 2dB, and the TFF will be shorter in weak signal, which might be helpful for better performance.

### 4.2.2.2. Passive Antenna with External LNA

In order to improve the GPS receiver sensitivity and TFF, an external LNA between the passive antenna and the L70 module is recommended. The reference design is shown as below.

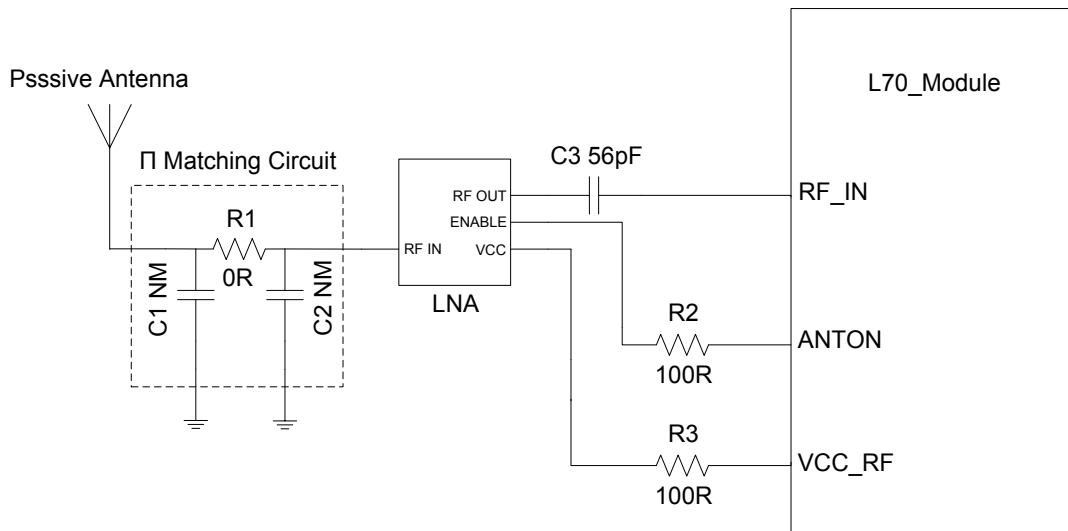

**Figure 18: Reference Design for Passive Antenna with LNA**

Here, C1, R1, C2 form a reserved matching circuit for passive antenna and LNA. By default, C1 and C2 are not mounted, R1 is 0 ohm. C3 is reserved for impedance matching between LNA and L70 module and the default value of C3 capacitor is 56pF which you might optimize according to the real conditions. ANTON is an optional pin which can be used to control the enable pin of the LNA.

#### NOTES

1. In order to be compatible with Quectel's GNSS module, it is recommended that the part number of the LNA component is MAX2659 or SKY65602. The both LNA components can support GPS and GLONASS system. For the details about the GNSS module, please contact Quectel's technical support team.
2. The power consumption of the device will be reduced by controlling "LNA ENABLE" through the pin "ANTON" of L70. If "ANTON" function is unused, please connect the pin "LNA ENABLE" to VCC to keep LNA always on.



# 5 Electrical, Reliability and Radio Characteristics

## 5.1. Absolute Maximum Ratings

Absolute maximum ratings for power supply and voltage on digital pins of the module are listed in the following table.

**Table 8: Absolute Maximum Ratings**

Parameter	Min.	Max.	Unit
Power Supply Voltage (VCC)	-0.3	5.0	V
Backup Battery Voltage (V_BCKP)	-0.3	5.0	V
Input Voltage at Digital Pins	-0.3	3.6	V
Input Power at RF_IN ( $P_{RF\_IN}$ )		15	dBm
Storage Temperature	-45	125	°C

**NOTE**

Stressing the device beyond the “Absolute Maximum Ratings” may cause permanent damage. These are stress ratings only. The product is not protected against over voltage or reversed voltage. If necessary, voltage spikes exceeding the power supply voltage specification, given in table above, must be limited to values within the specified boundaries by using appropriate protection diodes.

## 5.2. Operating Conditions

**Table 9: The Module Power Supply Ratings**

Parameter	Description	Conditions	Min.	Typ.	Max.	Unit
VCC	Supply voltage	Voltage must stay within the min/max values, including voltage drop, ripple, and spikes.	2.8	3.3	4.3	V
I <sub>VCCP</sub>	Peak supply current	VCC=3.3V			100	mA
V <sub>BCKP</sub>	Backup voltage supply		1.5	3.3	4.5	V
VCC <sub>RF</sub>	Output voltage RF section			VCC		V
TOPR	Normal operating temperature		-40	25	85	°C

### NOTES

1. The figure I<sub>VCCP</sub> can be used to determine the maximum current capability of power supply.
2. Operation beyond the "Operating Conditions" is not recommended and extended exposure beyond the "Operating Conditions" may affect device reliability.

## 5.3. Current Consumption

The values for current consumption are shown in the following table.

**Table 10: The Module Current Consumption**

Parameter	Conditions	Min.	Typ.	Max.	Unit
I <sub>VCC</sub> @Acquisition	@VCC=3.3V		18		mA
I <sub>VCC</sub> @Tracking	@VCC=3.3V		12		mA
I <sub>VCC</sub> @Standby	@VCC=3.3V		200		uA
I <sub>BCKP</sub> @Backup	@V <sub>BCKP</sub> =3.3V		7		uA

## NOTES

1. The VCC\_RF current is not reckoned in above consumption.
2. The tracking current is tested in the following conditions:
  - For Cold Start, 10 minutes after First Fix.
  - For Hot Start, 15 seconds after First Fix.

## 5.4. Electro-static Discharge

L70 module is an ESD sensitive device. ESD protection precautions should still be emphasized. Proper ESD handing and packaging procedures must be applied throughout the processing, handing and operation of any application.

The ESD bearing capability of the module is listed in the following table. Note that you should add ESD components to module pins in the particular applications.

**Table 11: The ESD Endurance Table (Temperature: 25°C, Humidity: 45%)**

Pin	Contact Discharge	Air Discharge
RF_IN	±5KV	±10KV
VCC	±5KV	±10KV
UART	±3KV	±6KV
Others	±2KV	±4KV

## 5.5. Reliability Test

**Table 12: Reliability Test**

Test Item	Conditions	Standard
Thermal Shock	-30°C...+80°C, 144 cycles	GB/T 2423.22-2002 Test Na IEC 68-2-14 Na
Damp Heat, Cyclic	+55°C; >90% Rh 6 cycles for 144 hours	IEC 68-2-30 Db Test
Vibration Shock	5~20Hz, 0.96m2/s3; 20~500Hz, 0.96m2/s3-3dB/oct, 1hour/axis; no function	2423.13-1997 Test Fdb IEC 68-2-36 Fdb Test

---

Heat Test	85°C, 2 hours, operational	GB/T 2423.1-2001 Ab IEC 68-2-1 Test
Cold Test	-40°C, 2 hours, operational	GB/T 2423.1-2001 Ab IEC 68-2-1 Test
Heat Soak	90°C, 72 hours, non-operational	GB/T 2423.2-2001 Bb IEC 68-2-2 Test B
Cold Soak	-45°C, 72 hours, non-operational	GB/T 2423.1-2001 A IEC 68-2-1 Test

---

Quectel  
Confidential

# 6 Mechanics

This chapter describes the mechanical dimensions of the module.

## 6.1. Mechanical View of the Module

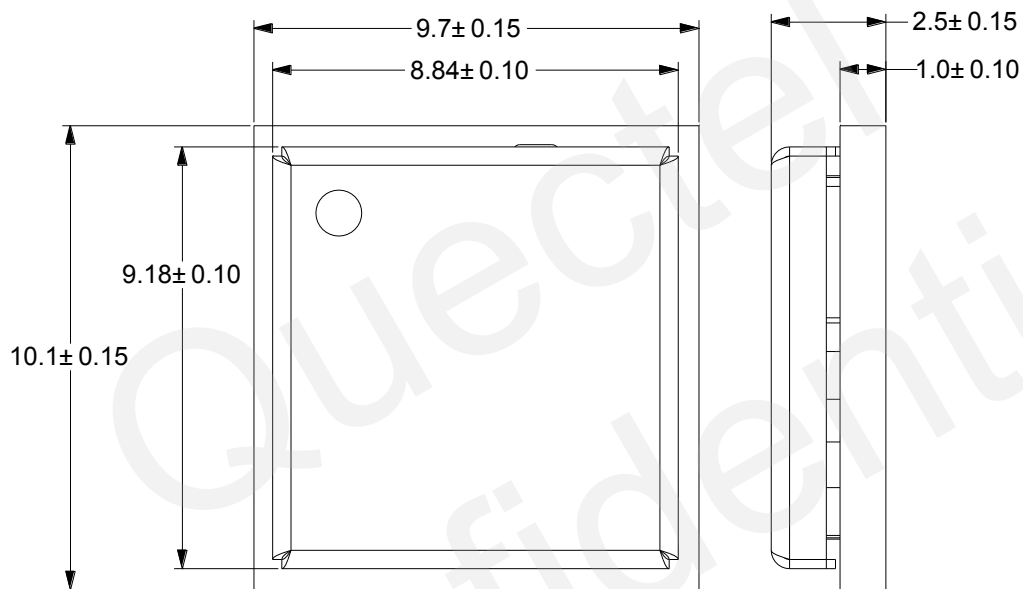

Figure 19: Top View and Side View (Unit: mm)

## 6.2. Bottom Dimension and Recommended Footprint

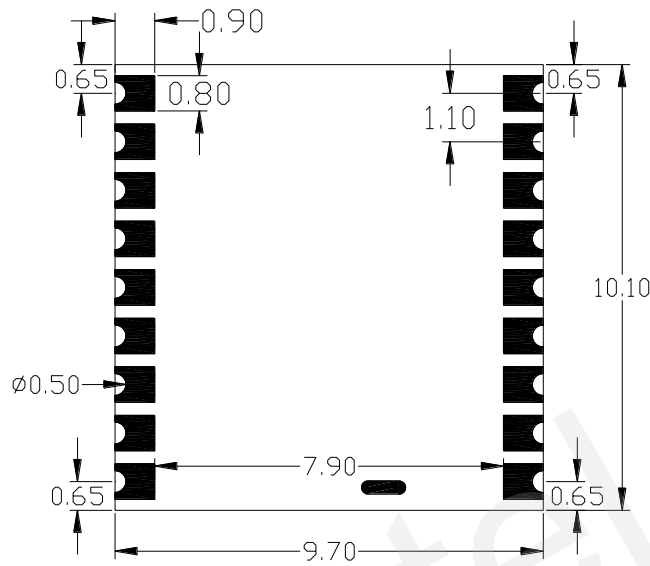

Figure 20: Bottom Dimension (Unit: mm)

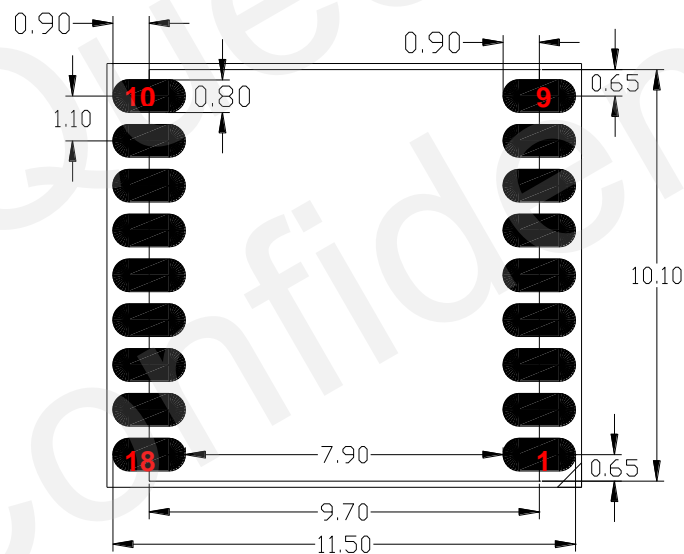

Figure 21: Footprint of Recommendation (Unit: mm)

### NOTE

For easy maintenance of this module and accessing to these pads, please keep a distance of no less than 3mm between the module and other components in host board.

### 6.3. Top View of the Module

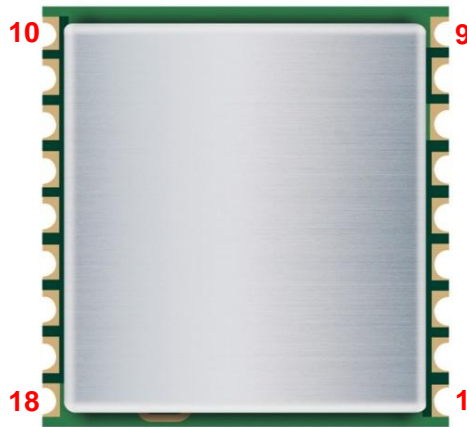

Figure 22: Top View of the Module

### 6.4. Bottom View of the Module

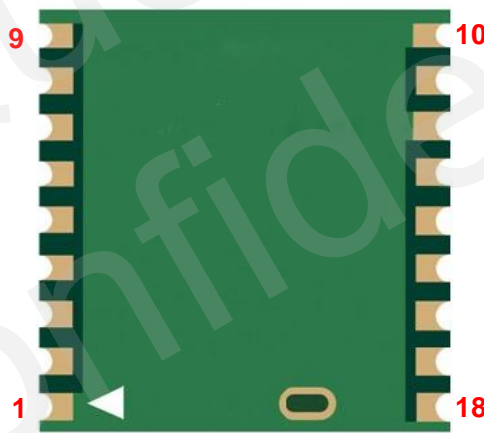

Figure 23: Bottom View of the Module

# 7 Manufacturing

## 7.1. Assembly and Soldering

L70 module is intended for SMT assembly and soldering in a Pb-free reflow process on the top side of the PCB. It is suggested that the minimum height of solder paste stencil is 130um to ensure sufficient solder volume. Pad openings of paste mask can be increased to ensure proper soldering and solder wetting over pads. It is suggested that peak reflow temperature is 235~245°C (for SnAg3.0Cu0.5 alloy). Absolute max reflow temperature is 260°C. To avoid damage to the module when it is repeatedly heated, it is suggested that the module should be mounted after the first panel has been reflowed. The following picture is the actual diagram which we have operated.

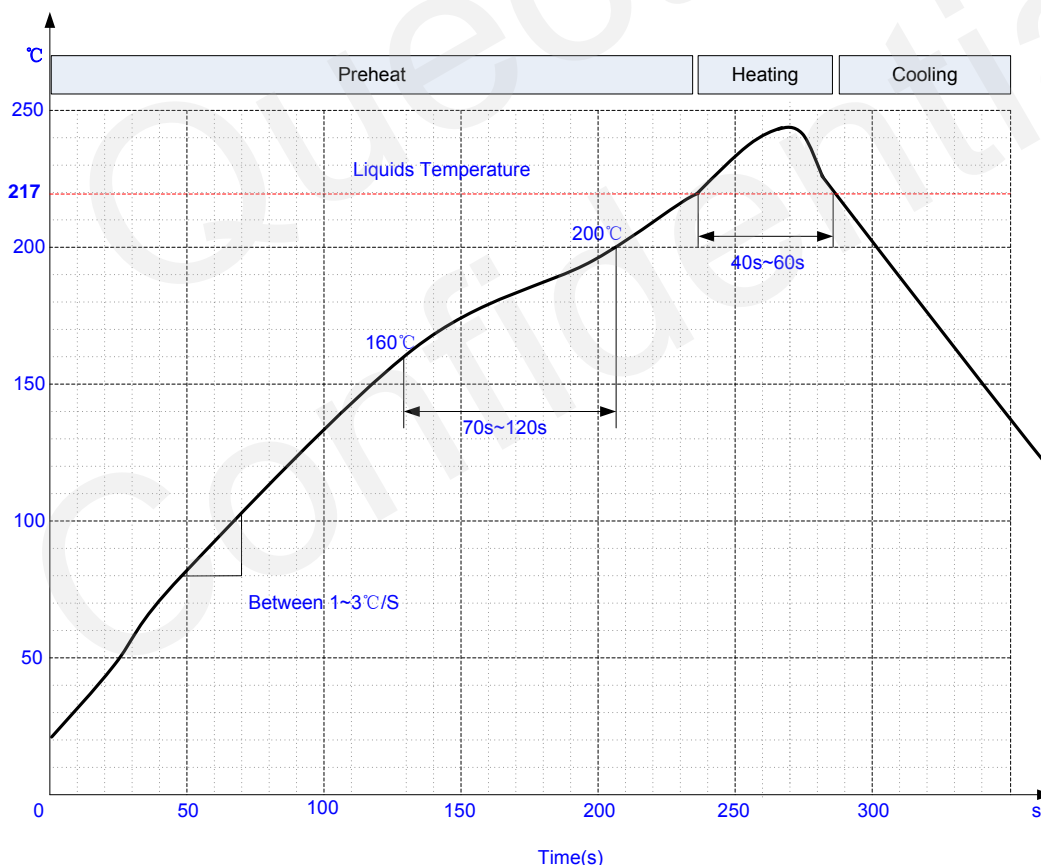

Figure 24: Ramp-soak-spike-reflow of Furnace Temperature



## 7.2. Moisture Sensitivity

L70 module is sensitivity to moisture absorption. To prevent L70 from permanent damage during reflow soldering, baking before reflow is required in following cases:

- Humidity indicator card: At least one circular indicator is no longer blue
- The seal is opened and the module is exposed to excessive humidity.

L70 should be baked for 192 hours at temperature  $40^{\circ}\text{C}+5^{\circ}\text{C}/-0^{\circ}\text{C}$  and  $<5\%$  RH in low-temperature containers, or 24 hours at temperature  $125^{\circ}\text{C}\pm 5^{\circ}\text{C}$  in high-temperature containers. Care should be taken that plastic tape is not heat resistant. L70 should be taken out before preheating, otherwise, the tape maybe damaged by high-temperature heating.

## 7.3. ESD Protection

L70 module is sensitive to ESD and requires special precautions when handling. Particular care must be exercised when handing patch antenna, duo to the risk of electrostatic charges.

## 7.4. Tape and Reel

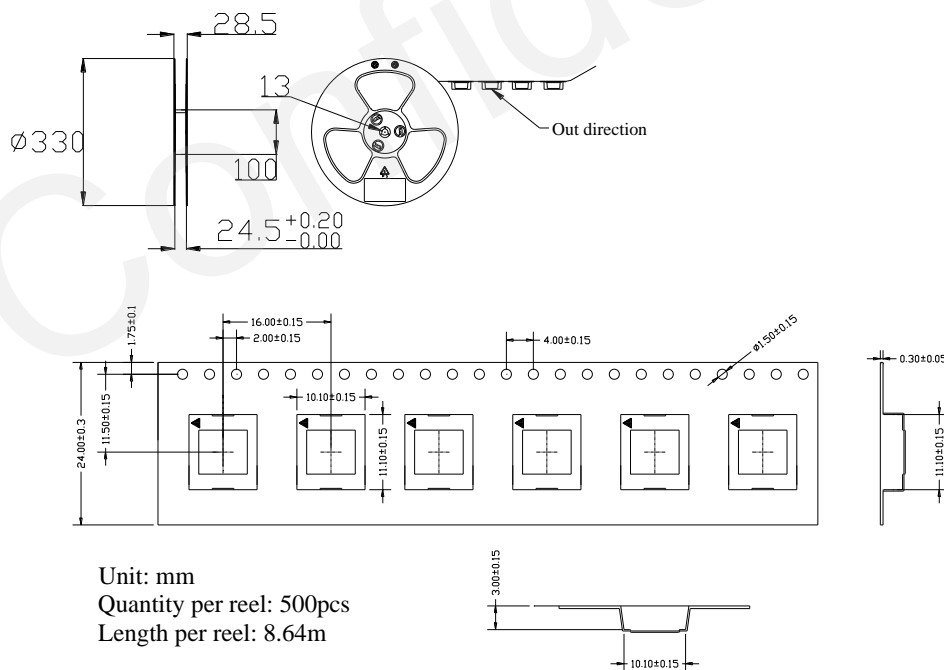

Figure 25: Tape and Reel Specification

**Table 13: Reel Packing**

Model Name	MOQ for MP	Minimum Package: 500pcs	Minimum Package x 4=2000pcs
L70	500pcs	Size: 370mm × 350mm × 56mm N.W: 0.25kg G.W: 1.00kg	Size: 380mm × 250mm × 365mm N.W: 1.1kg G.W: 4.4kg

## 7.5. Ordering Information

**Table 14: Ordering Information**

Model Name	Ordering Code
L70	L70B-M39

Quectel  
Confidential

# 8 Appendix Reference

**Table 15: Related Documents**

SN	Document Name	Remark
[1]	Quectel_L70_EVB_User Guide	L70 EVB User Guide
[2]	Quectel_L70_GPS_Protocol_Specification	L70 GPS Protocol Specification
[3]	Quectel_L70&L76_Reference_Design	L70&L76 Reference Design

**Table 16: Terms and Abbreviations**

Abbreviation	Description
AGPS	Assisted GPS
AIC	Active Interference Cancellation
CEP	Circular Error Probable
DGPS	Differential GPS
EASY	Embedded Assist System
EGNOS	European Geostationary Navigation Overlay Service
EPO	Extended Prediction Orbit
ESD	Electrostatic Discharge
GPS	Global Positioning System
GNSS	Global Navigation Satellite System
GGA	GPS Fix Data
GLL	Geographic Position – Latitude/Longitude
GLONASS	Global Navigation Satellite System

GSA	GNSS DOP and Active Satellites
GSV	GNSS Satellites in View
HDOP	Horizontal Dilution of Precision
I/O	Input /Output
Kbps	Kilo Bits Per Second
LNA	Low Noise Amplifier
MSAS	Multi-Functional Satellite Augmentation System
MOQ	Minimum Order Quantity
NMEA	National Marine Electronics Association
PDOP	Position Dilution of Precision
PMTK	MTK Proprietary Protocol
PPS	Pulse Per Second
PRN	Pseudo Random Noise Code
QZSS	Quasi-Zenith Satellite System
RHCP	Right Hand Circular Polarization
RMC	Recommended Minimum Specific GNSS Data
SBAS	Satellite-based Augmentation System
SAW	Surface Acoustic Wave
TTFF	Time To First Fix
UART	Universal Asynchronous Receiver & Transmitter
VDOP	Vertical Dilution of Precision
VTG	Course over Ground and Ground Speed, Horizontal Course and Horizontal Velocity
WAAS	Wide Area Augmentation System
Inom	Nominal Current
Imax	Maximum Load Current
Vmax	Maximum Voltage Value

---

Vnom	Nominal Voltage Value
Vmin	Minimum Voltage Value
VIHmax	Maximum Input High Level Voltage Value
VIHmin	Minimum Input High Level Voltage Value
VILmax	Maximum Input Low Level Voltage Value
VILmin	Minimum Input Low Level Voltage Value
VImax	Absolute Maximum Input Voltage Value
VImin	Absolute Minimum Input Voltage Value
VOHmax	Maximum Output High Level Voltage Value
VOHmin	Minimum Output High Level Voltage Value
VOLmax	Maximum Output Low Level Voltage Value
VOLmin	Minimum Output Low Level Voltage Value

---

Quectel  
Confidential