

Sep.1.2019 Copyright 2019 HIROSE ELECTRIC CO., LTD. All Rights Reserved.
In case of consideration for using Automotive equipment / device which demand high reliability, kindly contact our sales window correspondents.

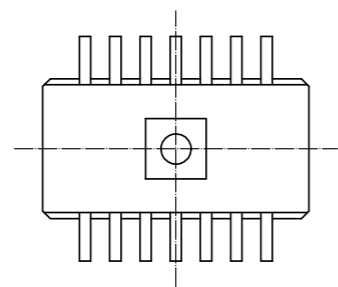

RECOMMENDED PATTERN

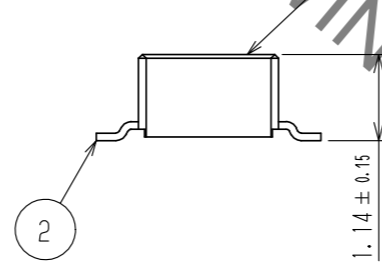
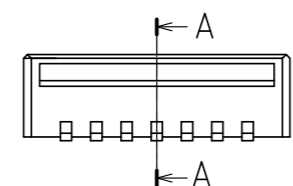
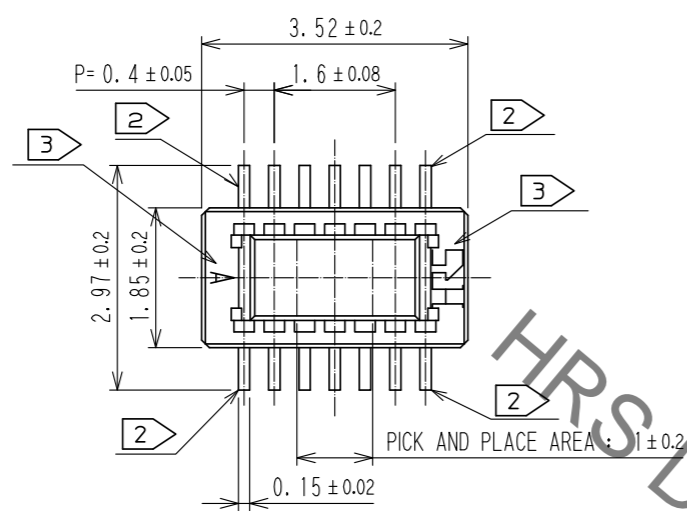
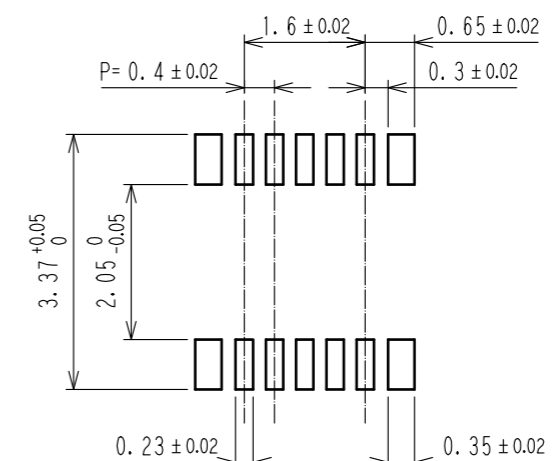

RECOMMENDED METAL MASK THICKNESS: 120 μm
RECOMMENDED METAL MASK OPENING RATIO: 80% FOR LEAD PAD

A-A(20:1)

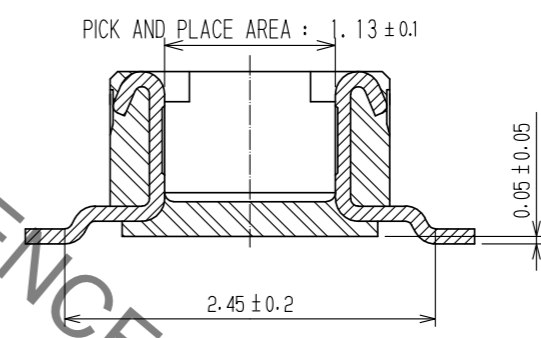

- NOTES 1. ALL LEADS CO-PLANARITY SHALL BE USED 0.1MAX.
 2. EACH ONE CONTACT AT 4 CORNERS SHALL BE USED AS METAL HOLD DOWN.
 3. HRS MARK AND CAV NO. IS INDICATED IN APPROX POSITION SHOWN.

2	PHOSPHOR BRONZE	CONTACT AREA: GOLD 0.05 μm MIN	6	PS	CLEAR, REINFORCEMENT COLLAR			
		SMT LEAD: GOLD 0.05 μm MIN	5	PS	BLACK			
		UNDERPLATING: NICKEL 1 μm MIN	4	POLYESTER	CLEAR, COVER TAPE			
1	LCP	BLACK, UL94V-0	3	PS	CLEAR, EMBOSSED CARRIER TAPE			
NO.	MATERIAL	FINISH . REMARKS	NO.	MATERIAL	FINISH . REMARKS			
UNITS mm		SCALE 10 : 1	COUNT 	DESCRIPTION OF REVISIONS		DESIGNED	CHECKED	DATE
HRS HIROSE ELECTRIC CO., LTD.		APPROVED : MO. ISHIDA	16. 10. 05	DRAWING NO. EDC-314291-58-01				
		CHECED : TS. MIYAZAKI	16. 10. 05	PART NO. DF40C-10DP-0.4V(58)				
		DESIGNED : SH. HOSODA	16. 10. 05	CODE NO. CL684-4035-0-58				
		DRAWN : SN. NUMAZAKI	16. 10. 04					

Sep.1.2019 Copyright 2019 HIROSE ELECTRIC CO., LTD. All Rights Reserved.
In case of consideration for using Automotive equipment / device which demand high reliability, kindly contact our sales window correspondents.

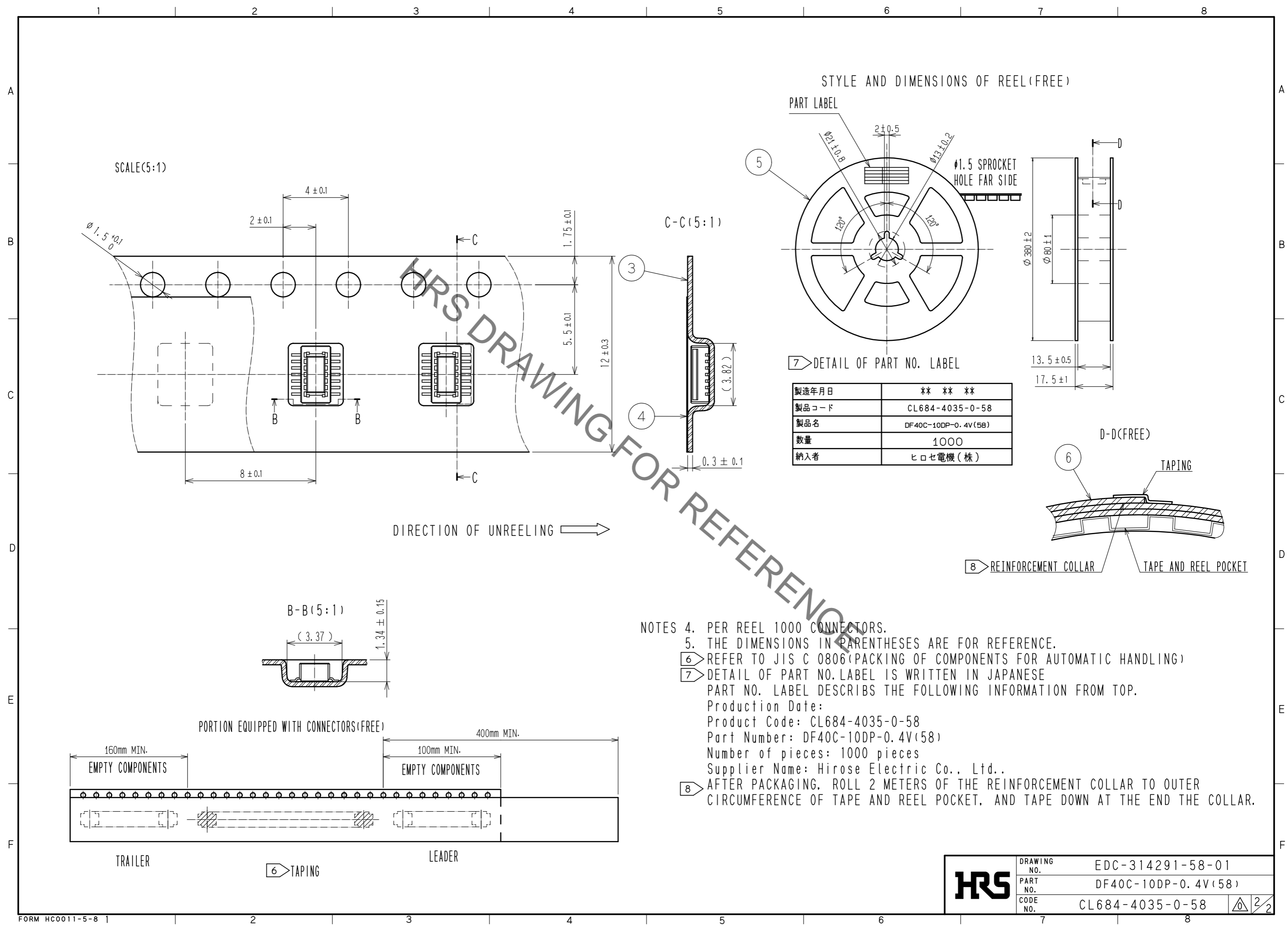

STYLE AND DIMENSIONS OF REEL (FREE)

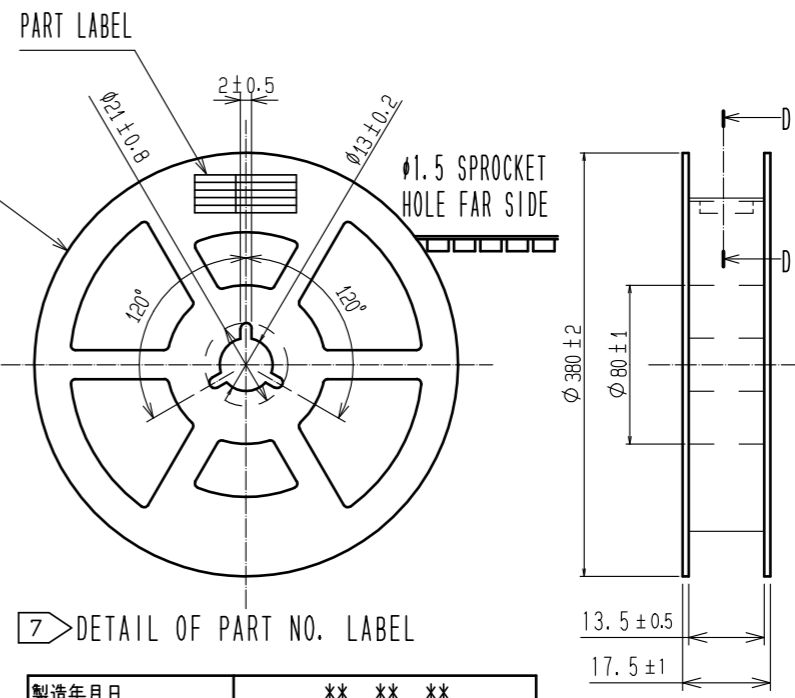

DETAIL OF PART NO. LABEL

製造年月日	** ** *
製品コード	CL684-4035-0-58
製品名	DF40C-10DP-0.4V(58)
数量	1000
納入者	ヒロセ電機(株)

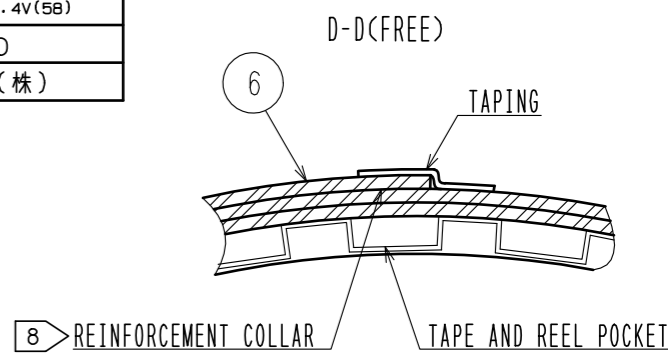

- NOTES
4. PER REEL 1000 CONNECTORS.
 5. THE DIMENSIONS IN PARENTHESES ARE FOR REFERENCE.
 6. REFER TO JIS C 0806 (PACKING OF COMPONENTS FOR AUTOMATIC HANDLING)
 7. DETAIL OF PART NO. LABEL IS WRITTEN IN JAPANESE
PART NO. LABEL DESCRIBES THE FOLLOWING INFORMATION FROM TOP.
Production Date:
Product Code: CL684-4035-0-58
Part Number: DF40C-10DP-0.4V(58)
Number of pieces: 1000 pieces
Supplier Name: Hirose Electric Co., Ltd..
 8. AFTER PACKAGING, ROLL 2 METERS OF THE REINFORCEMENT COLLAR TO OUTER CIRCUMFERENCE OF TAPE AND REEL POCKET, AND TAPE DOWN AT THE END THE COLLAR.

HRS	DRAWING NO.	EDC-314291-58-01
	PART NO.	DF40C-10DP-0.4V(58)
	CODE NO.	CL684-4035-0-58
		2/2