

ISO-TECH

Instruction Manual IDM 507 Process Multimeter

EN

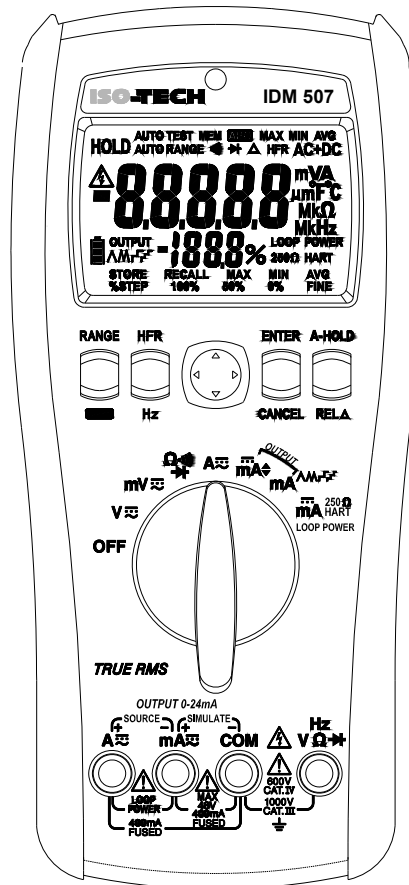

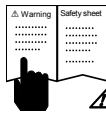

⚠ Read First

⚠ Safety Information

Understand and follow operating instructions carefully. Use the meter only as specified in this manual; otherwise, the protection provided by the meter may be impaired.

⚠ WARNING

Identifies hazardous conditions and actions that could cause **BODILY HARM** or **DEATH**.

⚠ CAUTION

Identifies conditions and actions that could **DAMAGE** the meter or equipment under test.











⚠ WARNING

- When using test leads or probes, keep your fingers behind the finger guards.
- Remove test lead from Meter before opening the battery door or Meter case.
- Use the Meter only as specified in this manual or the protection by the Meter might be impaired.
- Always use proper terminals, switch position, and range for measurements.
- Verify the Meter's operation by measuring a known voltage. If in doubt, have the Meter serviced.
- Do not apply more than the rated voltage, as marked on Meter, between terminals or between any terminal and earth ground.
- Only replace the blown fuse with the proper rating as specified in this manual.
- Use caution with voltages above 30 Vac rms, 42 Vac peak, or 30 Vdc. These voltages pose a shock hazard.
- To avoid false readings that can lead to electric shock and injury, replace battery as soon as low battery indicator.
- Disconnect circuit power and discharge all high-voltage capacitors before testing resistance, continuity, diodes, or capacitance.
- Do not use Meter around explosive gas or vapor.
- To reduce the risk of fire or electric shock do not expose this product to rain or moisture.
- Do not touch any circuits or parts of circuits if they may be subject to voltages higher than 30V_{AC} rms or 30V_{DC}.

⚠ CAUTION

- Disconnect the test leads from the test points before changing the position of the function rotary switch.
- Never connect a source of voltage with the function rotary switch in Ω , A, Loop-Power position.
- Do not expose Meter to extremes in temperature or high humidity.
- Never set the meter in Ω , A, Loop-Power function to measure the voltage of a power supply circuit in equipment that could result in damage the meter and the equipment under test.

Symbols as marked on the Meter and Instruction manual

	Risk of electric shock
	See instruction manual
	AC measurement
	DC measurement
	Equipment protected by double or reinforced insulation
	Battery
	Fuse
	Earth
	Conforms to EU directives
	Do not discard this product or throw away

Unsafe Voltage

To alert you to the presence of a potentially hazardous voltage, when the Tester detects a voltage ≥ 30 V or a voltage overload (OL) in V, mV. The "⚠" symbol is displayed and High voltage indicator is turned on.

Maintenance

Do not attempt to repair this Meter. It contains no user serviceable parts. Repair or servicing should only be performed by qualified personnel.

Cleaning

Periodically wipe the case with a dry cloth and detergent. Do not use abrasives or solvents.

The Meter Description

Front Panel Illustration

1. LCD display: 50,000 counts.
2. Push buttons for features.
3. Rotary switch for turn the power on / off and select the function.
4. Input terminal for A function / Loop-Power mode + / source mode +.
5. Input terminal for mA function / Loop-Power mode - / source mode - / simulate mode +.
6. Input terminal for V / Ω / Diode / Hz functions.
7. Common (Ground reference) input terminal for all functions.

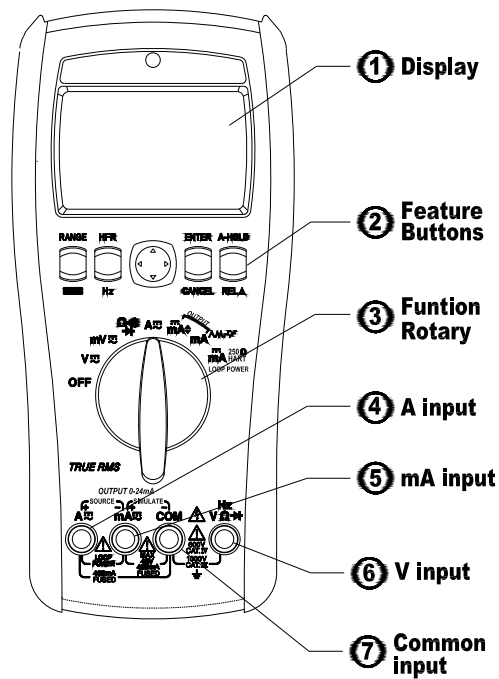

Making Basic Measurements

Preparation and Caution Before Measurement
⚠ : **Observe the rules** of ⚠ Warnings and ⚠ Cautions

When connecting the test leads to the **DUT (Device Under Test)** connect the common (mA) test lead before connecting the live lead; when removing the test leads, remove the test live lead before removing the common test lead.

The figures on the following pages show how to make basic measurements.

Auto / Manual Test

- When switch rotary in V / mV / A position, press the Function button > 1sec to enter auto test mode. In this mode, the meter showed the indication "**AUTO TEST**" on the display.
- Press the Function button that you can change to manual test mode from auto test mode.
- When the meter In auto test mode, it will automatically detect the input signal and determine. Then it will show the suitable result on the display.
- In manual test mode, you can press the Function button to select the measuring function.

Auto / Manual Range

- In a complex range of measuring function, you can start the auto range mode. This mode can automatically detect the input signal and determine. Then it will show the suitable result on the display.
- When press the RANGE button > 1sec, you can enter auto range mode. In this mode, the meter shows the indication "**AUTO RANGE**" on the display.
- Press the RANGE button that you can change to manual range mode from auto range mode.
- In manual range mode, you can press the RANGE button to select the measuring range.

Measuring Voltage

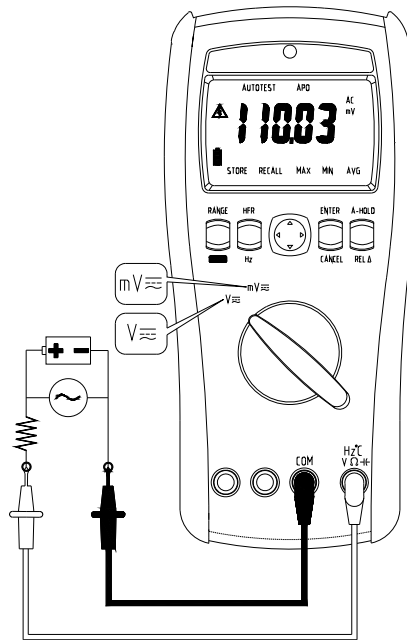

- Press the Function button to select the presently measuring function (AC / DC / AC+DC).
- Press the Function button > 1 sec to enter the auto test mode, and press again to exit this mode.
- The auto test mode can automatically determine the voltage / current which is AC or DC.
- The AC+DC mode is defined by $\sqrt{AC^2 + DC^2}$

Measuring Current

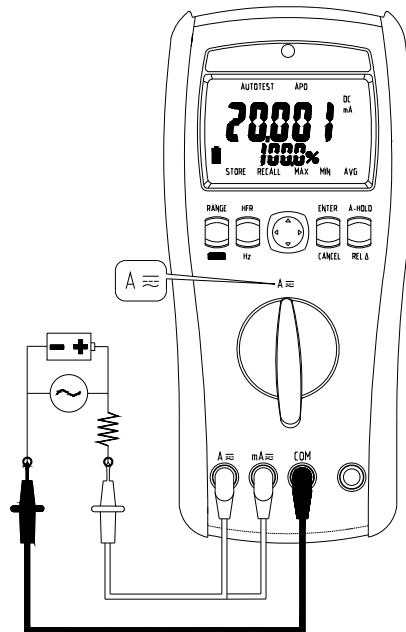

- The basic operations are same as voltage function.

Measuring Frequency

- When measuring voltage or current, press the Hz button to measuring the frequency for voltage or current.
- Press the Hz button again to exit this mode.

High Frequency Reject (Low Pass Filter)

- When measuring voltage or current, press the HFR button to equip with low pass filter.
- Press the HFR button again to exit this mode.
- The cut-off frequency (-3dB point) is at **800Hz**.

Measuring Resistance

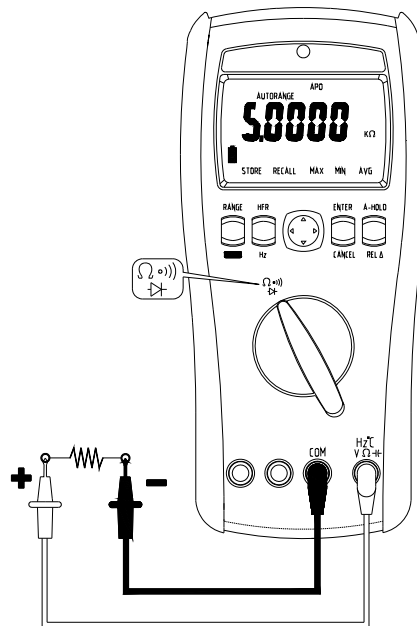

- Press the Function button to select the presently measuring function (Ω / Continuity Check / Diode Test).

Continuity Check

- Press the Function button to select continuity check when the rotary is in resistance position.
- The buzzer allows you to quickly continuity tests without watching the display.
- The buzzer sounds when a short ($< 30\Omega$) is detected.

Diode Test

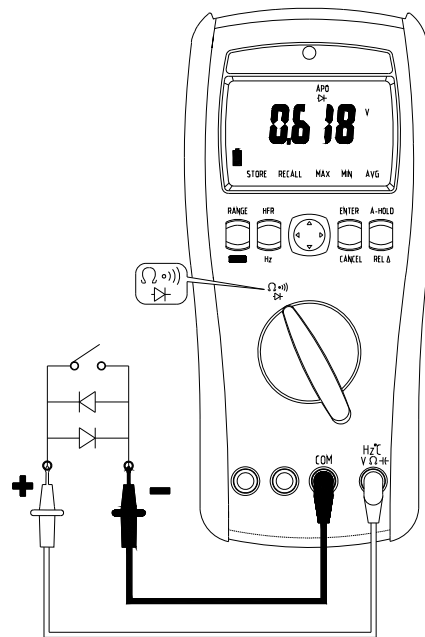

- Press the Function button to select diode test when the rotary is in resistance position.
- In diode test, you can test direction and forward voltage.
- If the DUT was not a diode (Open, Short, Resistance or Capacitance), the display showed "-----".

DC Current Output

- To use the DC current output function, turn the rotary in output position (Adjustable DC output or Auto DC output).
- The DC current output function has both modes: Source Mode & Simulate Mode
- The output mode has both types: 0-20mA & 4-20mA. That is selectable. When power on, press the RANGE button to select. And the selection was set to default.





Adjustable DC Current Output

- To use the adjustable DC current output function, turn the rotary in adjustable output position ()
- In this function, you can adjust the DC current output.
- %STEP: 0% / 25% / 50% / 75% / 100% / 120% / 125%
- Fast Setup: 0% / 50% / 100%
- Fine Setup : Minimum resolution 1uA, 0mA to 24mA

% STEP	0-20mA Mode	4-20mA Mode
0%	0mA	4mA
25%	5mA	8mA
50%	10mA	12mA
75%	15mA	16mA
100%	20mA	20mA
120%	24mA	N/A
125%	N/A	24mA

Auto DC Current Output

- To use the auto DC current output function, turn the rotary in auto output position ()
- In this function, you can press the BLUE button to select 4 kinds of the auto DC current output.
- Press the HOLD button to pause / continue the output.

Mode	Type	Action
	Linear	0% to 100% to 0% per 40 sec
	Linear	0% to 100% to 0% per 20 sec
	25% Step	0% to 100% to 0%, a step per 15 sec
	25% Step	0% to 100% to 0%, a step per 5 sec

Source Mode

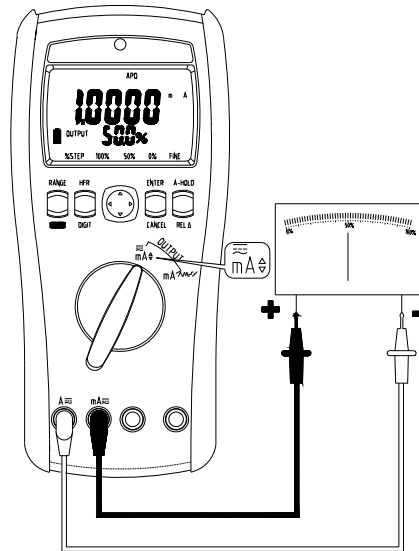

- When meter in the source mode, it provided internal power supply (Batteries > 4.5V) to drive the DC current output.
- To operate in the source mode, put the both probes in A terminal (Source +) and mA terminal (Source -). Then the meter will automatically enter the source mode.
- Do not turn the rotary when the probe in the A terminal. This action maybe caused > 30mA to pass through the loop circuit.
- The source mode can work in both modes: Adjustable DC output & Auto DC output
- In auto DC current output mode, you can press the HOLD button to pause / continue the output.

Simulate Mode

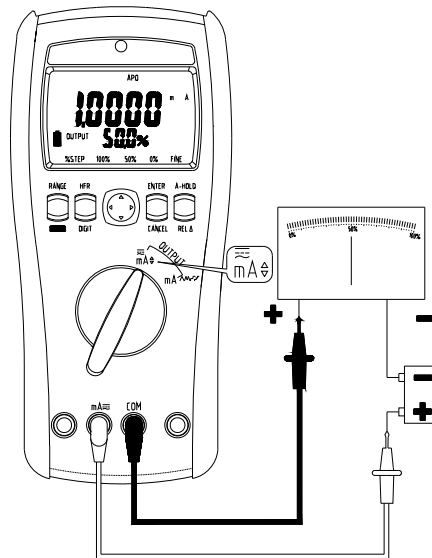

- When meter in the simulate mode, it used external power supply (12V to 48V) to drive the DC current output.
- To operate in the simulate mode, put the both probes in mA terminal (Simulate +) and COM terminal (Simulate -). Then the meter will automatically enter the simulate mode.
- Do not turn the rotary when the probe in the A terminal. This action maybe caused $> 30\text{mA}$ to pass through the loop circuit.
- The simulate mode can work in both modes: Adjustable DC output & Auto DC output.
- In auto DC current output mode, you can press the HOLD button to pause / continue the output.

Loop Power

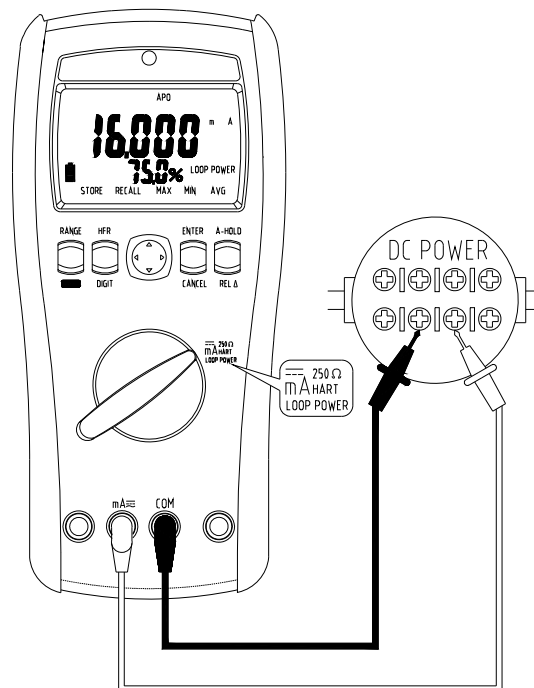

- In this function, the meter provided internal power supply to output > 24V / 20mA.
- To operate in the loop power function, put the probes in A terminal (Source +) and mA terminal (Source -). Then the meter will automatically drive.
- Do not turn the rotary when the probe in the A terminal. This action may cause > 30mA to pass through the loop circuit.

250Ω Hart

- When switch rotary in loop power position, press the Function button to equip with 250Ω Hart.
- Press the Function button again to strip 250Ω Hart.

Auto Hold

- Press the A-HOLD button to start the auto hold mode, and press again to exit.
- In this mode, the meter show the indication “**HOLD**” on the display.
- When the difference is bigger (> **50d**) than hold data, and it is also **stable**. Then the meter will automatically hold a new data on the display.
- When the reading is smaller the limit, the auto hold mode is not working.

Function	Limit
V	< 0.1V
mV	< 1mV
others	No Limit

Relative Δ

- Press the REL Δ button to start relative mode. The meter remembers the presently reading as reference and shows the indication “ **Δ** ” on the display.
- In this mode, the meter deducts the reference from each reading, and shows the result on the display.
- Press the REL Δ button to select display (Reference or Result). The indication “ **Δ** ” blinks on the display when it shows the result.
- Press the REL Δ button > 1sec to exit this mode.

Maximum / Minimum / Average

- When blink cursor of menu is MAX / MIN / AVG, press the ENTER button to start MAX / MIN / AVG mode.
- In this mode, the meter records each data to compare the maximum and minimum. And calculate the average.
- You can move the blink cursor of menu to select what was showed on the display.
- Press the CANCEL button to exit this mode.

Store / Recall

- When blink cursor of menu is STORE, press the ENTER button to store the presently reading to memory.
- The meter can store maximum 100 data in the memory.
- You can enter the recall mode to review the stored data.
- When blink cursor of menu is RECALL, press the ENTER button to start recall mode.
- In the recall mode, you can press the UP or DOWN button to review the stored data. When press it > 1sec, you can fast search.
- Press the CANCEL button to exit this mode.
- To clear all data of stored function in memory, see the **Power On Options**.

Auto Power Off

- If there is no any action in the meter, then the meter will automatically turn off to save the power of batteries.
- The APO time is default 20 minutes.
- When the meter was power on, the APO was set to default. To disable the APO, see the **Power On Options**.

Auto Backlight

- The backlight is automatically turned on at dark environment.
- When the meter was power on, the auto backlight was set to default. To disable the automatic, and enable / disable the backlight, see the **Power On Options**.

Buzzer

- Equip 2kHz tone buzzer.
- Valid button press: Beep once
- Invalid button press: Beep twice
- To enable / disable the buzzer, see the **Power On Options**.

Power On Options

When turn the power on, press the function button to execute the below options.

Button	Action
RANGE	Select the output type (0-20mA & 4-20mA) and set it to default.
FUNCTION	Disable APO.
HFR	Show the firmware version.
ENTER	Enable / Disable the buzzer and set the option to default.
CANCEL	Clear all data of stored function in memory.
A-HOLD	Enable backlight & disable automatic.
REL Δ	Disable backlight & disable automatic.

Battery and Fuse Replacement

Refer to the following figure to replace fuse and the batteries :

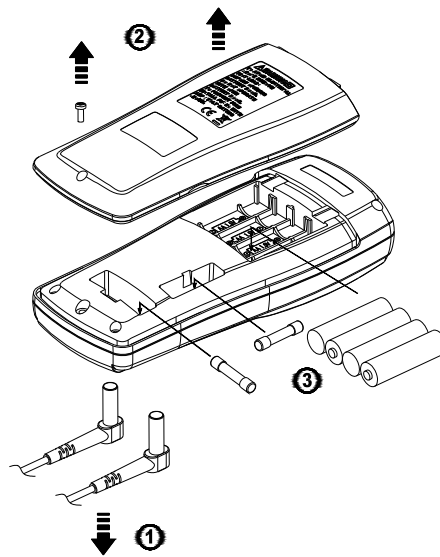

- Be always replaced the batteries & fuse that conform the specifications.
- Battery Type: 4 x 1.5V IEC LR6 or AA size
- Fuse Type: 2 x 440mA, 1000V IR 10kA Fuse (Bussmann DMM-B-44/100)
- When the battery low indication “” was showed on the display, replace the batteries.
- To save the power of batteries, you can disable the Auto Backlight and Buzzer. See the **Power On Options** on how to disable both functions. Besides, always use the simulate mode on the DC current output mode.
- To check the fuse, use the other meter to inspect it.

Specifications

General Specifications

Maximum voltage applied to any terminal :

1000V_{DC} or 1000V_{AC} rms

Display : 50,000 counts, over range to 110%.

Polarity Indication :

Automatic, positive implied, negative indicated.

Over Range Indication : OL

Measuring Rate : 10 samples per second

Power Requirements : 4 x 1.5V IEC LR6 or AA size

Battery Life: 100 hours

Low Battery Indication : “  ” is displayed when the batteries voltage drops below operating voltage.

Low Battery Voltage: Approx 4.5V

Auto Power Off: Default 20 minutes.

Operating Ambient : -10°C to 30°C (< 85% RH),
30°C to 40°C (< 75% RH),
40°C to 50°C (< 45% RH)

Storage Temperature :

-20°C to 60°C, 0% RH to 80% RH (batteries not fitted)

Temperature Coefficient :

0.1 x (Specified Accuracy) / °C, < 18°C or > 28°C

Operating Altitude : 6561.7ft (2000m)

Calibration Cycle : 1 time per year

Weight : 630g including battery.

Dimensions (W x H x D) : 95 x 207 x 52 (mm) with holster.

Accessories :

Batteries, test leads, user manual & software CD.

Safety : Complies with EN 61010-1, EN 61010-2-030

CAT IV 600V, CAT III 1000V

I	The circuits not connected to mains.
II	The circuits directly connected to Low-voltage installation.
III	The building installation.
IV	The source of the Low-voltage installation.

EMC : EN 61326-1, EN 61326-2, EN 55011, EN 61000-4

Pollution Degree : 2

Shock Vibration : 5Hz to 55Hz, 3g max

Sinusoidal vibration for MIL-PRE-28800F class 2.

Drop Protection : 5ft (1.5m)

Indoor Use

Electrical Specifications

- Accuracy is \pm (% reading + number of digits)
- Ambient temperature: $23^{\circ}\text{C} \pm 5^{\circ}\text{C}$ (< 80% RH)
- For the best measurements, with REL Δ function to compensate for offsets.

1. Voltage

Function	Range	Accuracy
AC ^[1]	50.000mV 500.00mV	Sine Wave: \pm (0.7% + 20d) for 40Hz to 70Hz \pm (1.5% + 40d) for 71Hz to 10kHz
	5.0000V 50.000V 500.00V 1000.0V ^[2]	Sine Wave: \pm (0.5% + 20d) for 40Hz to 70Hz \pm (1.5% + 40d) for 71Hz to 1000Hz \pm (3.0% + 80d) for 1001Hz to 10kHz
DC	50.000mV	\pm (0.05% + 30d)
	500.00mV 5.0000V 50.000V 500.00V 1000.0V	\pm (0.05% + 5d)

[1] Below 5% of AC range, add 20d to accuracy.
[2] The bandwidth of range is 40Hz to 1kHz.

Input Protection : $1000V_{\text{DC}}$ or $1000V_{\text{AC}}$ rms

Input Impedance : $10M\Omega$, < 100pF

Bandwidth : 40Hz to 10kHz

Minimum Resolution : $1\mu\text{V}$ in the 50mV range

CMRR / NMRR (Common / Normal Mode Rejection Ratio) :

V_{AC} : CMRR > 60dB at DC, 50Hz / 60Hz

V_{DC} : CMRR > 100dB at DC, 50Hz / 60Hz

NMRR > 50dB at DC, 50Hz / 60Hz

AC Conversion Type :

AC conversions are ac-coupled, true rms responding, calibrated to the sine wave input.

For non-sine wave add the following Crest Factor corrections :

For Crest Factor of 1.4 to 2.0, add 1.0% to AC accuracy.

For Crest Factor of 2.0 to 2.5, add 2.5% to AC accuracy.

For Crest Factor of 2.5 to 3.0, add 4.0% to AC accuracy.

AC+DC Accuracy : AC accuracy + DC accuracy + 1.0%

HFR Accuracy : AC accuracy + 1.0% for 40Hz to 400Hz

The Cut-Off Frequency of HFR : 800Hz (-3dB point)

Attenuation Characteristic of HFR : Approx -24dB

2. Current

Function	Range	Accuracy
AC ^[1]	50.000mA 1.000A	Sine Wave: ± (1.0% + 20d) for 40Hz to 70Hz ± (2.0% + 40d) for 71Hz to 10kHz
DC	50.000mA 1.000A	± (0.05% + 5d)

[1] Below 5% of AC range, add 20d to accuracy.

Input Protection : Equipped with High Energy Fuse.
440mA, 1000V IR 10kA Fuse (Bussmann DMM-B-44/100)

Input Impedance :

0.1Ω at A input, 13Ω at mA input. Not contain protection circuit.

Bandwidth : 40Hz to 10kHz

Minimum Resolution : 1μA in the 50mA range

Maximum Measuring Time :

1 minutes at A input, 10 minutes at mA input.

Rest time is 20 minutes minimum.

AC Additional Specifications :

The AC additional specifications are same as voltage.

3. Frequency Counter

Range	Resolution	Accuracy
500.00Hz	0.01Hz	± 3d
5.0000kHz	0.1Hz	
50.000kHz	1Hz	
100.00kHz	10Hz	

Input Protection : 1000V_{DC} or 1000V_{AC} rms

Minimum Frequency : 5Hz

4. Frequency Counter Sensitivity

Function	Range	Sensitivity (Peak-to-Peak)	
		5 to 10k (Hz)	10k to 100k (Hz)
mV	50.000mV 500.00mV	10mV	100mV
V	5.0000V	1V	1V
	50.000V 500.00V 1000.0V	1V	Unspecified
	A	50.000mA	
1.000A		300mA	

5. Resistance

Range	Resolution	Output Current	Accuracy
500.00Ω	0.01Ω	1mA	± (0.2% + 30d)
5.0000kΩ	0.1Ω	100uA	± (0.2% + 10d)
50.000kΩ	1Ω	10uA	
500.00kΩ	10Ω	1uA	± (0.5% + 10d)
5.0000MΩ	100Ω	100nA	± (1.0% + 10d)
50.00MΩ ^[1]	10kΩ	10nA	± (2.0% + 10d)

[1] There is a little rolling less than < 20d.

Input Protection : 1000V_{DC} or 1000V_{AC} rms

Maximum Open Circuit Voltage : Approx 3.5V

6. Continuity Check

Range	Resolution	Output Current	Accuracy
500.00Ω	0.01Ω	1mA	± (0.1% + 30d)

Input Protection : 1000V_{DC} or 1000V_{AC} rms

Maximum Open Circuit Voltage : Approx 3.5V

Continuity Threshold : < 30Ω

Continuity Indicator : 2kHz Tone Buzzer

7. Diode Test

Range	Resolution	Output Current	Accuracy
2.000V	1mV	±1mA	± (1.0% + 10d)

Input Protection : 1000V_{DC} or 1000V_{AC} rms

Maximum Open Circuit Voltage : Approx ±3V

8. DC Voltage Output

Function	Range	Accuracy
Source Mode	32.0V	± 5.0%
Loop Power	32.0V	± 5.0%

Input Protection : Equipped with High Energy Fuse.

440mA, 1000V IR 10kA Fuse (Bussmann DMM-B-44/100)

Power Source : Internal batteries, > 4.5V

Output Short Protection

9. Auto DC Current Output

Range	Resolution	Accuracy
0.000mA to 20.000mA Over range to 24.000mA	1uA	± (0.5% + 5d)
4.000mA to 20.000mA Over range to 24.000mA		

Input Protection : Equipped with High Energy Fuse.
440mA, 1000V IR 10kA Fuse (Bussmann DMM-B-44/100)





Power Source :

Source Mode : Internal batteries, > 4.5V

Simulate Mode : External loop supply, 6V to 48V

Output Short Protection

10. Auto DC Current Output

Mode	Type	Action
	Linear	0% to 100% to 0% per 40 sec
	Linear	0% to 100% to 0% per 20 sec
	25% Step	0% to 100% to 0%, a step per 15 sec
	25% Step	0% to 100% to 0%, a step per 5 sec

Input Protection : Equipped with High Energy Fuse.
440mA, 1000V IR 10kA Fuse (Bussmann DMM-B-44/100)

Power Source :

Source Mode : Internal batteries, > 4.5V

Simulate Mode : External loop supply, 6V to 48V

Output Short Protection

11. Loop Power

Function	Range	Driver	Accuracy
Normal	50.000mA	30V / 1.25kΩ	± (0.05% + 5d)
250Ω Hart	50.000mA	24V / 1kΩ	± (0.05% + 5d)

Input Protection : Equipped with High Energy Fuse.
440mA, 1000V IR 10kA Fuse (Bussmann DMM-B-44/100)

Power Source : Internal batteries, > 4.5V

Minimum Output Voltage : 24V

Output Short Protection

Limited Warranty

This meter is warranted to the original purchaser against defects in material and workmanship for 3 years from the date of purchase. During this warranty period, RS Components will, at its option, replace or repair the defective unit, subject to verification of the defect or malfunction.

This warranty does not cover fuses, disposable batteries, or damage from abuse, neglect, accident, unauthorized repair, alteration, contamination, or abnormal conditions of operation or handling.

Any implied warranties arising out of the sale of this product, including but not limited to implied warranties of merchantability and fitness for a particular purpose, are limited to the above. RS Components shall not be liable for loss of use of the instrument or other incidental or consequential damages, expenses, or economic loss, or for any claim or claims for such damage, expense or economic loss. Some states or countries laws vary, so the above limitations or exclusions may not apply to you. For full terms and conditions, refer to the RS website.

Asia

Iso-Tech
460 Alexandra Road, #15-01A
PSA Building
Singapore 119963

USA

7410 Pebble Drive
Fort Worth
Texas 76118-6961

Europe

Iso-Tech
PO Box 99
Corby
Northamptonshire
NN17 9RS
United Kingdom

Canada

1701 Woodward Drive
Ste 108 Ottawa
Ontario K2C 0R4, Canada

Japan

West Tower (12th Floor)
Yokohama Business Park
134 Godocho, Hodogaya
Yokohama, Kanagawa 240-0005 Japan

South America

Av. Pdte. Eduardo Frei M. 6001-71
Centro Empresas El Cortijo
Conchali, Santiago, Chile