

## HINGE L 45/45

Article Nr. 21.1378/0

[See the product on the website](#) →

[Download CAD Files](#) →

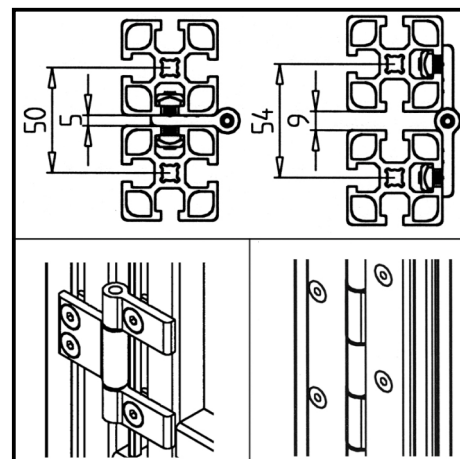
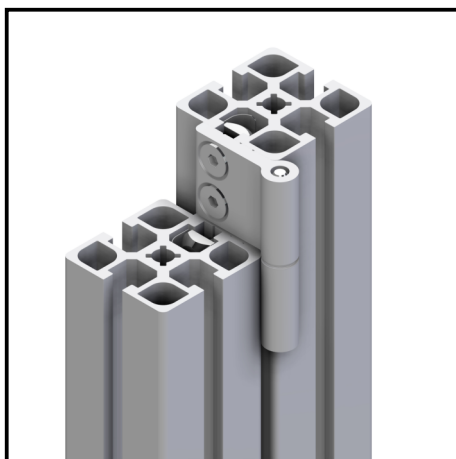
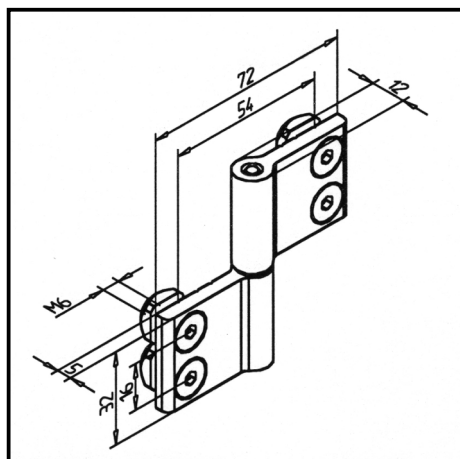

### TECHN. DATA / ITEMS SUPPLIED

- Aluminium, anodized E6/EV1
- With stainless steel shaft
- With fastening material steel, zinc plated
- Load capacity up to 400 N
- Weight = 0.089 kg/piece

### APPLICATIONS

- Detachable doors, hatches, moving parts on profiles 45
- Guard unit fixing angle
- If the hinges are arranged in the opposite direction, non-detachable and horizontally mounted structures can also be produced
- Connection of profiles 45 at various angles

### ASSEMBLY

- Fasten to profile groove with supplied hardware
- The hinge profile 5GB **part no.** 20.0093/0 (not anodized) is available for the production of hinges in variable lengths and bore spacings as well as piano hinges