

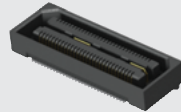

QSH-060-01-L-D-DP-A

QSH-060-01-L-D-A-K



QSH-030-01-F-D-A

QSH SERIES

(0,50 mm) .0197"

# HIGH SPEED GROUND PLANE SOCKET

## SPECIFICATIONS

For complete specifications and recommended PCB layouts see [www.samtec.com?QSH](http://www.samtec.com?QSH)

**Insulator Material:**

Liquid Crystal Polymer

**Contact Material:**

Phosphor Bronze

**Plating:** Au or Sn over 50µ" (1,27 µm) Ni

**Current Rating:**

Contact:

2 A per pin

(1 pin powered per row)

Ground Plane:

25 A per ground plane

(1 ground plane powered)

**Operating Temp Range:**

-55°C to +125°C

**Voltage Rating:**

125 VAC (5 mm Stack Height)

**Max Cycles:** 100

ROHS Compliant: Yes

**Processing:**

Lead-Free Solderable: Yes

**SMT Lead Coplanarity:**

(0,10 mm) .004" max (030-060)

(0,15 mm) .006" max (090)

**Board Stacking:**

For applications requiring more than two connectors per board contact [ipg@samtec.com](mailto:ipg@samtec.com)

**Board Mates:**

QTH

**Cable Mates:**

HQCD, HQDP

(See Also Available note)



10 year Mixed Flowing Gas with 50µ" Gold  
Call Samtec for maximum mated cycles

Blade & Beam Design

Integral metal plane for power or ground

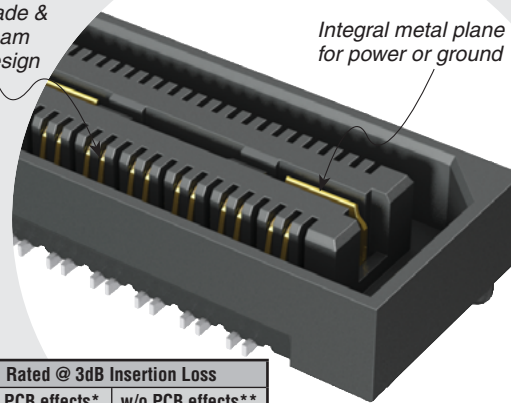

QTH/QSH 5 mm Stack Height	Type	Rated @ 3dB Insertion Loss	
		with PCB effects*	w/o PCB effects**
Single-Ended Signaling	-D	9 GHz / 18 Gbps	9.5 GHz / 19 Gbps
Differential Pair Signaling	-D	8 GHz / 16 Gbps	10.5 GHz / 21 Gbps
Differential Pair Signaling	-DP	9.5 GHz / 19 Gbps	16.5 GHz / 33 Gbps

\*Performance data includes effects of a non-optimized PCB.

\*\*Test board losses de-embedded from performance data.

Performance data for other stack heights and complete test data available at [www.samtec.com?QSH](http://www.samtec.com?QSH) or contact [sig@samtec.com](mailto:sig@samtec.com)

**infinch**  
CERTIFIED

28+  
Gbps

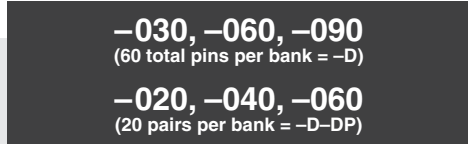

**-F**  
= Gold Flash on Signal Pins and Ground Plane, Matte Tin on tails

**-L**  
= 10µ" (0,25 µm) Gold on Signal Pins and Ground Plane, Matte Tin on tails

**-C\***  
= Electro-Polished Selective  
50µ" (1,27 µm) min Au over 150µ" (3,81 µm) Ni on Signal Pins in contact area,  
10µ" (0,25 µm) min Au over 50µ" (1,27 µm) Ni on Ground Plane in contact area,  
Matte Tin over 50µ" (1,27 µm) min Ni on all solder tails

**-D**  
= Single-Ended

**-D-DP**  
= Differential Pair (-01 only)

**-K**  
= (8,25 mm) .325" DIA Polyimide Film Pick & Place Pad

**-TR**  
= Tape & Reel (-090 positions maximum)

**-L**  
= Latching Option (Not available on -060 (-D-DP) & -090 positions)

QTH LEAD STYLE	MATED HEIGHT WITH QSH*
-01	(5,00) .197
-02	(8,00) .315
-03	(11,00) .433
-04	(16,00) .630
-05	(19,00) .748
-07	(25,00) .984

\*Processing conditions will affect mated height.

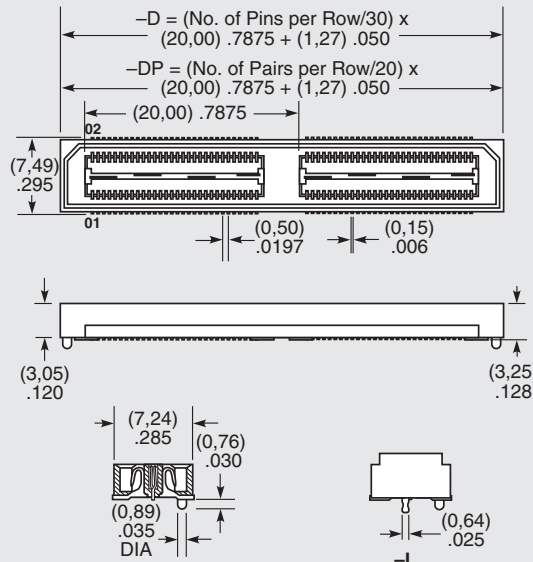

\*Note: -C Plating passes 10 year MFG testing

Note: Some lengths, styles and options are non-standard, non-returnable.

## OTHER SOLUTIONS

- Board Spacing Standoffs. See SO Series

## RECOGNITIONS

For complete scope of recognitions see [www.samtec.com/quality](http://www.samtec.com/quality)



FILE NO. E111594 FILE NO. 090371\_0\_000

## ALSO AVAILABLE (MOQ Required)

- 14 mm, 15 mm, 22 mm and 30 mm stack height (Caution: Some automatic placement/inspection machines may have component height restrictions. Please consult machinery specifications.)
- 30µ" (0,76 µm) Gold (Specify -H plating for Data Rate cable mating applications.)
- Edge Mount & Guide Posts
- 80 (-DP), 120, 150 positions per row
- Retention Option
- Contact Samtec.