



Impact Printer Mechanism (M192)

Stock No. 244-597

General specification

Print method

Impact dot matrix printer (8 print solenoids)

Print format

1. Total number of dots: Maximum 240 dots/dot line
2. Number of columns: Maximum 40 (5 x 7 dot matrix and 1 dot column space)
(5 columns/print solenoid x 8)

Printing speed

1. 1 dot line: Typ. 83ms (at 4.8V⁻⁻⁻, 25°C, continuous printing)
2. 5 x 7 dot matrix (3-dot line spacing):
1.5 lines/sec $\pm 15\%$ (at 4.8V⁻⁻⁻, 25°C, continuous printing)

Character size

1. Dot pitch: Horizontal; 0.2mm, vertical; 0.37mm
2. 5 x 7 dot matrix: 1.1mm (W) x 2.6mm (H)

Copying capability

1 original + 1 copy

Paper

57.5mm wide (RS stock no. 202-868)

Paper feed

Paper is automatically fed every dot line. Fast paper feeding is possible (3.6 lines/sec $\pm 15\%$ (at 4.8V⁻⁻⁻, 25°C, continuous printing)). Paper release mechanism.

Inking

Ribbon cassette (black; RS stock no. 200-846, purple; RS stock no. 202-830), ribbon is automatically fed while motor is rotating.

Motor

1. Terminal voltage: $4.8 \pm_{1.0}^{0.7} V^{---}$ (Ni-Cd battery, nominal voltage 4.8V)
 $4.8 \pm_{1.0}^{0.4} V^{---}$ (when stabilized power supply is used)
2. Mean current: Typ. 0.35 A (4.8V⁻⁻⁻, at 25°C, as measured with an ammeter)

Timing detector

Tachometer-generator (connected directly to the motor)

Reset detector

Reed switch

Print solenoid

1. Terminal voltage: $4.8 \pm_{1.5}^{0.7} V^{---}$ (Ni-Cd battery, nominal voltage 4.8V)
 $4.8 \pm_{1.5}^{0.4} V^{---}$ (when stabilized power supply is used)
2. DC resistance $1.3\Omega \pm 10\%$ (at 25°C)

Fast paper feed trigger solenoid

1. Terminal voltage: $4.8 \pm_{1.0}^{0.7} V^{---}$ (Ni-Cd battery, nominal voltage 4.8V)
 $4.8 \pm_{1.0}^{0.4} V^{---}$ (when stabilized power supply is used)
(Use the same power supply as that for the motor so that the terminal voltages
m a t c h)
2. DC resistance $20\Omega \pm 10\%$ (at 25°C)

Connection

1. Printer side: PCB fixed to the frame (with 2.5mm pitch copper pattern)
2. Circuit side: Flat cables or lead wires.

Operating ambient temperature

0 to 50°C

Overall dimensions

91mm (W) x 46.9mm (D) x 15.8mm (H) (excluding manual feed knob)

Weight

Approx. 100g

Note: Terminal voltage is the voltage at the printer board terminal, and it is the voltage which should be ensured after the voltage on the drive circuit side drops due to energizing.

Connections

A copper foil edge connector with a 2.5mm pitch is fixed to the printer frame. The printer can be connected to external circuits by soldering flat cables or lead wires to the copper foil pattern. When selecting and using cables and wires, the current capacity must be taken into account for each of the print solenoid signals, i.e. the common, A, B, C, D, E, F, G and H. Be sure that the soldered portions are not placed under mechanical stress.

Ribbon cassette handling

1. It is desirable to mount the ribbon cassette after removing the paper.
2. Before mounting the cassette, the ribbon should be tightened by rotating the ribbon feed roller in the direction shown by the arrow. Then place the cassette so as to insert the ribbon between the gap by matching the cutouts on the left and right sides of the printer frame. The cassette can be easily installed by pushing it down gently. Be careful not to lock the ribbon feed roller (see figures 1 and 2).

(It will be easier to install if the cassette is pressed down while rotating the ribbon feed roller in the direction of the arrow.)

Even if the ribbon is tucked up or sags while mounting, it can be tightened and fixed to its proper position by rotating the roller after inserting the cassette frame. (See figure 3.)

3. To remove the ribbon cassette, push the portion marked PUSH with a finger. The other side of the cassette will go up. Then rotate and remove the cassette using the PUSH mark as the centre of rotation. When designing the case, be sure to provide the necessary space which allows the

Figure 1.

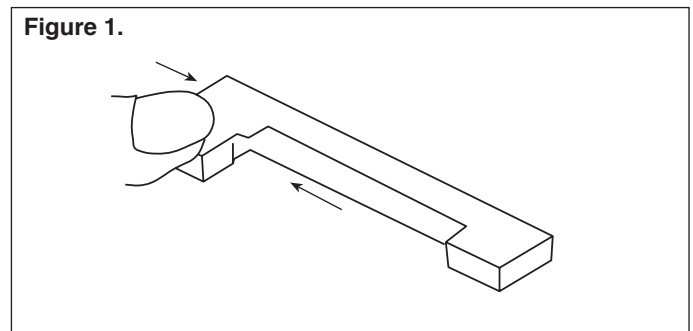

rotation. (See figure 4.)

Figure 2.

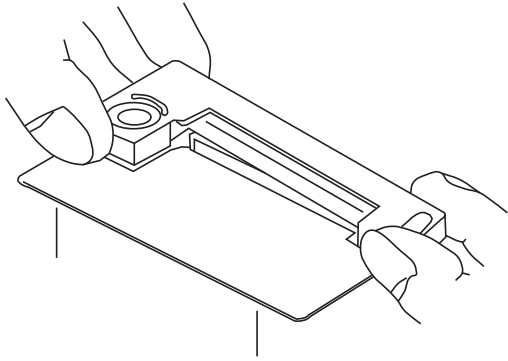

Figure 3.

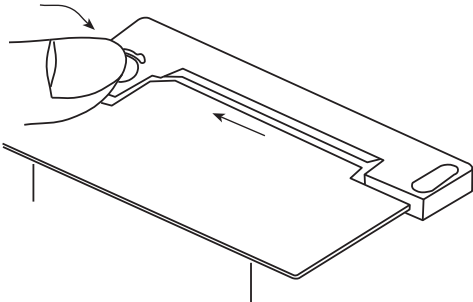
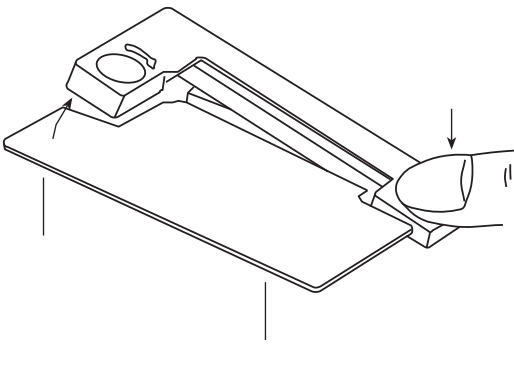

Figure 4.



Paper entrance and paper holder design

1. The centre of the paper holder on the case side must be aligned with the centre of the paper entrance width on the printer side. The paper guide must be able to guide paper which is 57.5 ± 0.5 mm wide.
2. Clearance between the paper holder on the case side and the roll paper width must be 2.0mm or less. However, the clearance must be sufficient to prevent the holder from pressing or rubbing against both sides of the paper roll.
3. Paper supply load at the paper entrance should be 30g or less.

Paper cutter design

When designing the paper cutter, the following should be taken into account:

1. The more the paper near the paper exit (i.e. paper cutter mounting position) approaches the vertical, the more the paper resonates, making printing noise greater.
2. On the other hand, the more the paper approaches the horizontal, the more the paper feed load increases. This may cause paper feeding problems.

Case design around the paper feed knob

Because the paper feed knob rotates while the printer is operating, the following items should be considered:

1. The paper feed knob must not touch the case.
2. The knob must not project outside the case. The knob should be protected.

Paper roll-in protection

When designing the case, be sure to prevent printed paper from being taken up again.

External interference protection

Since a reed switch is employed as the reset detector, be sure to protect the printer from external magnetic fields. In particular the upper surface of the cover should be kept away from magnetic fields.

Other notes on designing the outer case

The openings in the case, such as the paper entrance and paper cut position (i.e. paper exit) should be as small as possible in order to minimize noise.

Notes on printer handling

1. Printing without paper or ribbon **is prohibited** to avoid damaging the printer.
2. Because plated steel plate is used in this unit, the cut edges may get rusty.