

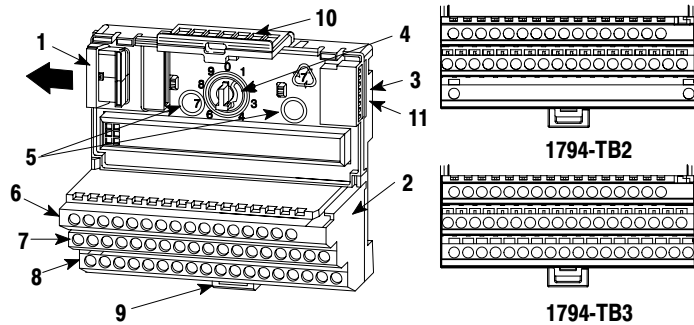

Installation Instructions

FLEX I/O Terminal Base

(Cat. No. 1794-TB2, -TB3)



Component Identification

1	Female flexbus connector
2	Terminal base unit (1794-TB3 shown)
3	Male flexbus connector
4	Keyswitch – Set to the position required for the installed module
5	Mounting holes for panel mounting
6	Input/output terminal strip for connecting input/output wiring
7	Terminal strip for input/output commons
8	Terminal strip for power connections – 2 terminals on 1794-TB2, 18 terminals on 1794-TB3
9	Locking tab
10	Module locking latch
11	Cover plug for male flexbus connector

Important User Information

Because of the variety of uses for the products described in this publication, those responsible for the application and use of these products must satisfy themselves that all necessary steps have been taken to assure that each application and use meets all performance and safety requirements, including any applicable laws, regulations, codes and standards. In no event will Allen–Bradley be responsible or liable for indirect or consequential damage resulting from the use or application of these products.

Any illustrations, charts, sample programs, and layout examples shown in this publication are intended solely for purposes of example. Since there are many variables and requirements associated with any particular installation, Allen–Bradley does not assume responsibility or liability (to include intellectual property liability) for actual use based upon the examples shown in this publication.

Allen–Bradley publication SGI–1.1, Safety Guidelines for Application, Installation, and Maintenance of Solid–State Control (available from your local Allen–Bradley office), describes some important differences between solid–state equipment and electromechanical devices that should be taken into consideration when applying products such as those described in this publication.

Reproduction of the contents of this copyrighted publication, in whole or part, without written permission of Rockwell Automation, is prohibited.

Throughout this publication, notes may be used to make you aware of safety considerations. The following annotations and their accompanying statements help you to identify a potential hazard, avoid a potential hazard, and recognize the consequences of a potential hazard.

WARNING



Identifies information about practices or circumstances that can cause an explosion in a hazardous environment, which may lead to personal injury or death, property damage, or economic loss.

ATTENTION



Identifies information about practices or circumstances that can lead to personal injury or death, property damage, or economic loss.

IMPORTANT

Identifies information that is critical for successful application and understanding of the product.

ATTENTION**Environment and Enclosure**

This equipment is intended for use in a Pollution Degree 2 industrial environment, in overvoltage Category II applications (as defined in IEC publication 60664-1), at altitudes up to 2000 meters without derating.

This equipment is considered Group 1, Class A industrial equipment according to IEC/CISPR Publication 11. Without appropriate precautions, there may be potential difficulties ensuring electromagnetic compatibility in other environments due to conducted as well as radiated disturbance.

This equipment is supplied as “open type” equipment. It must be mounted within an enclosure that is suitably designed for those specific environmental conditions that will be present, and appropriately designed to prevent personal injury resulting from accessibility to live parts. The interior of the enclosure must be accessible only by the use of a tool. Subsequent sections of this publication may contain additional information regarding specific enclosure type ratings that are required to comply with certain product safety certifications.

See NEMA Standards publication 250 and IEC publication 60529, as applicable, for explanations of the degrees of protection provided by different types of enclosures. Also, see the appropriate sections in this publication, as well as the Allen-Bradley publication 1770-4.1, (“Industrial Automation Wiring and Grounding Guidelines”), for additional installation requirements pertaining to this equipment.

ATTENTION**Preventing Electrostatic Discharge**

This equipment is sensitive to electrostatic discharge, which can cause internal damage and affect normal operation. Follow these guidelines when you handle this equipment:

- Touch a grounded object to discharge potential static.
 - Wear an approved grounding wriststrap.
 - Do not touch connectors or pins on component boards.
 - Do not touch circuit components inside the equipment.
 - If available, use a static-safe workstation.
 - When not in use, keep modules in appropriate static-safe packaging.
-

ATTENTION

Remove field-side power before removing or inserting this module. This module is designed so you can **remove and insert it under backplane power**. When you remove or insert a module with field-side power applied, an electrical arc may occur. An electrical arc can cause personal injury or property damage by:

- sending an erroneous signal to your system's field devices causing unintended machine motion
- causing an explosion in a hazardous environment

Repeated electrical arcing causes excessive wear to contacts on both the module and its mating connector. Worn contacts may create electrical resistance.

Mounting on a DIN Rail

ATTENTION

Do not remove or replace a terminal base unit when power is applied. Interruption of the flexbus can result in unintended operation or machine motion.



1. Remove the cover plug (if used) in the male connector of the unit to which you are connecting this terminal base unit.
2. Check to make sure that the 16 pins in the male connector on the adjacent device are straight and in line so that the mating female connector on this terminal base unit will mate correctly.
3. Make certain that the female flexbus connector **C** is **fully retracted** into the base unit.

ATTENTION

Make certain the female connector **C** is fully retracted into the base unit. Failure to do so can damage the pins in the mating connector when the base unit is rotated into place.



4. Position the terminal base on the 35 x 7.5mm DIN rail **A** (A-B pt. no. 199-DR1).

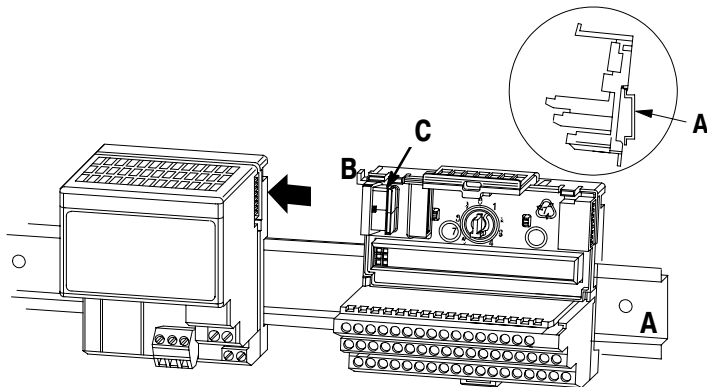

Position terminal base at a slight angle and hooked over the top of the DIN rail A.

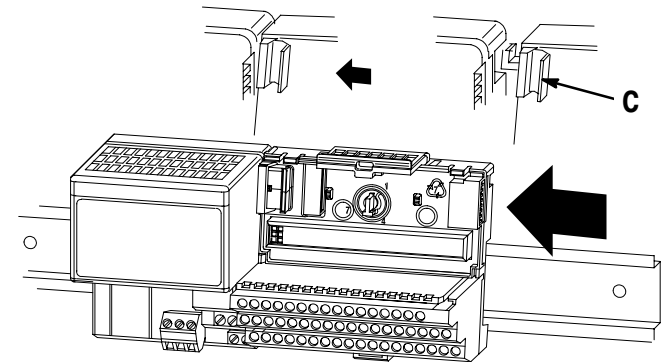

Slide the terminal base unit over tight against the adapter. Make sure the hook on the terminal base slides under the edge of the adapter and the flexbus connector is fully retracted.

ATTENTION

Do not force the terminal base into the adjacent base/adapter. Forcing the units together can bend or break the hook and allow the units to separate and break communication over the backplane.

5. Rotate the terminal base onto the DIN rail with the top of the rail hooked under the lip on the rear of the terminal base. **Use caution to make sure that the female flexbus connector does not strike any of the pins in the mating male connector.**

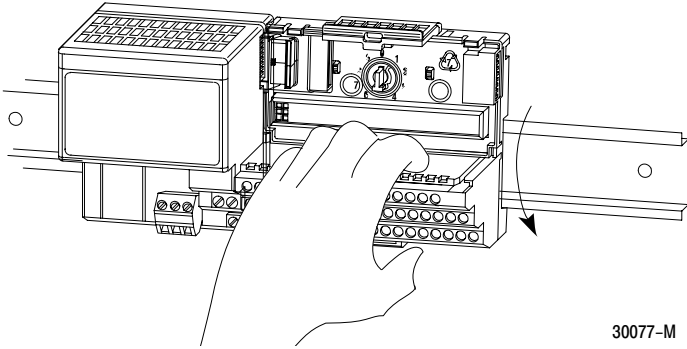

30077-M

Press down on the terminal base unit to lock the terminal base on the DIN rail. If the terminal base does not lock into place, use a screwdriver or similar device to open the locking tab, press down on the terminal base until flush with the DIN rail and release the locking tab to lock the base in place.

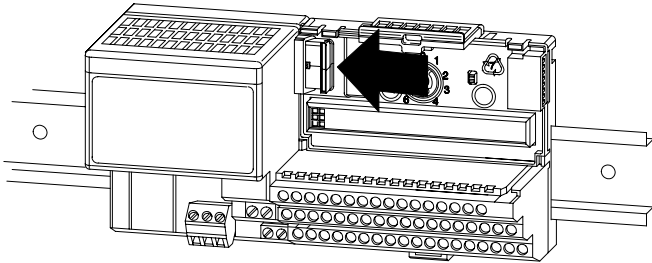

Gently push the flexbus connector into the side of the adapter to complete the backplane connection.

6. For specific wiring information, refer to the installation instructions for the module you are installing in this terminal base unit.
7. Repeat the above steps to install the next terminal base.

Wiring

ATTENTION Total current draw through the terminal base unit is limited to 10A. Separate power connections may be necessary.



1. Make wiring connections as described in the installation instructions included with the specific module that mounts on your terminal base unit.
2. Connect power and common from this terminal base unit to the next using jumpers or individual external wiring.

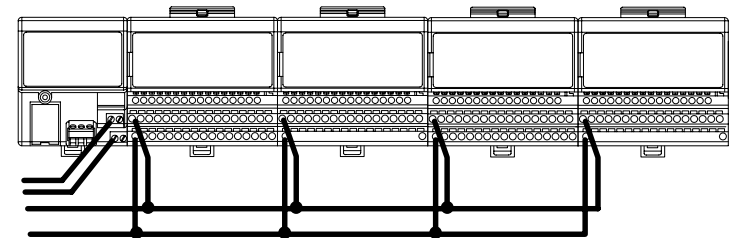
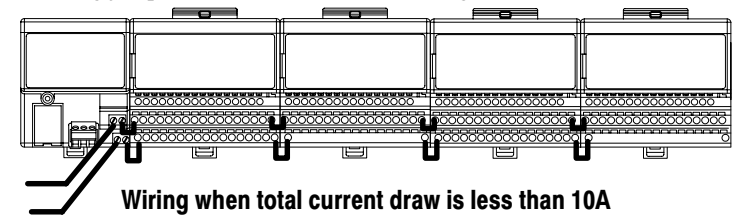

WARNING**EXPLOSION HAZARD**

- Do not disconnect equipment unless power has been removed or the area is known to be nonhazardous.
- Do not disconnect connections to this equipment unless power has been removed or the area is known to be nonhazardous. Secure any external connections that mate to this equipment by using screws, sliding latches, threaded connections or other means provided with this product.
- Substitution of components may impair suitability for Class I, Division 2.

The following information applies when operating this equipment in hazardous locations:

Products marked "CL I, DIV 2, GP A, B, C, D" are suitable for use in Class I Division 2 Groups A, B, C, and D Hazardous Locations and nonhazardous locations only. Each product is supplied with markings on the rating nameplate indicating the hazardous location temperature code. When combining products within a system, the most adverse temperature code (lowest "T" number) may be used to help determine the overall temperature code of the system. Combinations of equipment in your system are subject to investigation by the local Authority Having Jurisdiction at the time of installation.

WARNING**EXPLOSION HAZARD -**

- Do not disconnect equipment unless power has been removed or the area is known to be nonhazardous.
- Do not disconnect connections to this equipment unless power has been removed or the area is known to be nonhazardous. Secure any external connections that mate to this equipment by using screws, sliding latches, threaded connectors, or other means provided with this product.
- Substitution of components may impair suitability for Class I, Division 2.
- If this product contains batteries, they must only be changed in an area known to be nonhazardous.

Informations sur l'utilisation de cet équipement en environnements dangereux:

Les produits marqués CL I, DIV 2, GP A, B, C, D ne conviennent que une utilisation en environnements de Classe I Division 2 Groupes A, B, C, D dangereux et non dangereux. Chaque produit est livré avec des marquages sur sa plaque d'identification qui indiquent le code de température pour les environnements dangereux. Lorsque plusieurs produits sont combinés dans un système, le code de température le plus défavorable (code de température le plus faible) peut être utilisé pour déterminer le code de température global du système. Les combinaisons d'équipements dans le système sont sujettes à inspection par les autorités locales qualifiées au moment de l'installation.

AVERTISSEMENT**RISQUE D'EXPLOSION -**

- Couper le courant ou s'assurer que l'environnement est classé non dangereux avant de débrancher l'équipement.
 - Couper le courant ou s'assurer que l'environnement est classé non dangereux avant de débrancher les connecteurs. Fixer tous les connecteurs externes reliés à cet équipement à l'aide de vis, loquets coulissants, connecteurs filetés ou autres moyens fournis avec ce produit.
 - La substitution de composants peut rendre cet équipement inadapté à une utilisation en environnement de Classe 1, Division 2.
 - S'assurer que l'environnement est classé non dangereux avant de changer les piles.
-

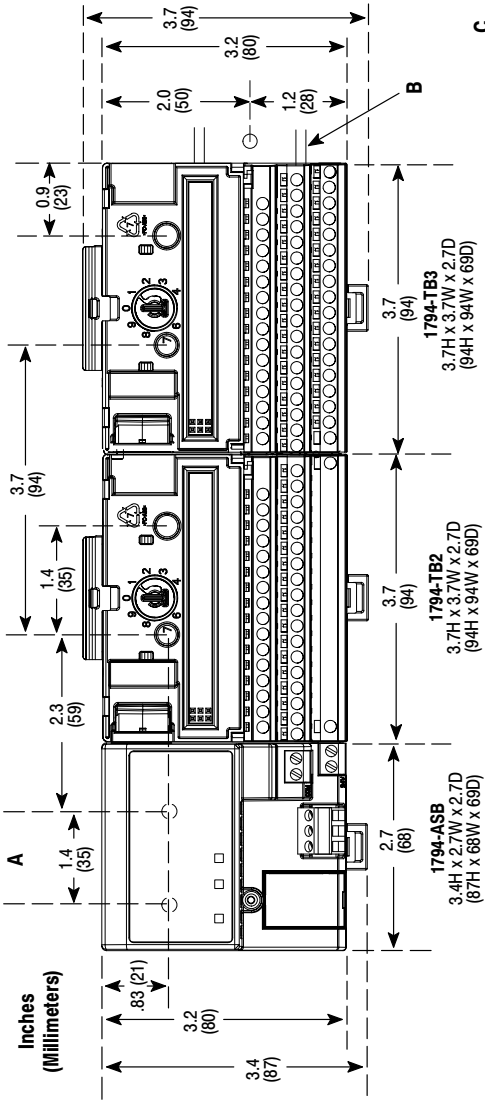

Secure DIN rail approximately every 200mm.

A = Mounting hole dimensions for optional mounting kit

B = DIN rail

C = Operating temperature 1.0 (25.4) below each module when mounted in any position must not exceed 55 degrees C (131 degrees F)



Specifications – Terminal Base Cat. No. 1794–TB2 and –TB3

Number of Terminals	1794–TB2 – 1 row of 16 1 row of 18 1 row of 2 1794–TB3 – 1 row of 16 2 rows of 18
Terminal Screw Torque	7 pound–inches (0.6Nm)
Dimensions (with module installed in base) Inches (Millimeters)	3.7H x 3.7W x 2.7D (94H x 94.0W x 69D)
Current Capacity	10A maximum
Voltage Rating	132V ac maximum
Isolation Voltage	Channel-to-channel isolation determined by inserted module.
Environmental Conditions	
Operating Temperature	IEC 60068–2–1 (Test Ad, Operating Cold) IEC 60068–2–2 (Test Bd, Operating Dry Heat) IEC 60068–2–14 (Test Nb, Operating Thermal Shock) 32 to 131°F (0 to 55°C)
Storage Temperature	IEC 60068–2–1 (Test Ab, Unpackaged, Nonoperating Cold) IEC 60068–2–2 (Test Bb, Unpackaged, Nonoperating Dry Heat) IEC 60068–2–14 (Test Na, Unpackaged, Nonoperating Thermal Shock) –40 to 185°F (–40 to 85°C)
Relative Humidity	IEC 60068–2–30 (Test Db, Unpackaged, Nonoperating Damp Heat) 5 to 95%, noncondensing
Shock Operating Nonoperating	IEC 60068–2–27 (Test Ea, Unpackaged Shock) 30g 50g
Vibration	IEC 60068–2–6 (Test Fc, Operating) 5g @ 10–500Hz
ESD Immunity	IEC 61000–4–2 4kV contact discharges 8kV air discharges
Radiated RF Immunity	IEC 61000–4–3 10V/m with 1kHz sine–wave 80% AM from 30MHz to 1000MHz
EFT/B Immunity	IEC 61000–4–4 ±2kV @ 5kHz on signal ports

Specifications continued on next page.

Specifications – Terminal Base Cat. No. 1794–TB2 and –TB3

Surge Transient Immunity	IEC 61000–4–5 ±1kV line–line (DM) and ±2kV line–earth (CM) on signal ports
Conducted RF Immunity	IEC 61000–4–6 10V rms with 1kHz sine wave 80% AM from 150kHz to 80MHz
Emissions	CISPR 11 Group 1, Class A (with appropriate enclosure)
Enclosure Type Rating	None (open–style)
Conductors Wire Size	12 gauge (4mm ²) stranded copper wire maximum rated at 75°C or greater 3/64 inch (1.2mm) insulation maximum Established by installed module
Category ¹	
Agency Certification (when product is marked)	<ul style="list-style-type: none"> UL UL Listed Industrial Control Equipment UL UL Listed for Class I, Division 2 Group A, B, C and D Hazardous Locations CSA CSA Certified Process Control Equipment for Class I, Division 2 Group A, B, C, D Hazardous Locations EEx² European Union 94/9/EEC ATEX Directive, compliant with EN 50021; Potentially Explosive Atmospheres, Protection “n” CE² European Union 89/336/EEC EMC Directive, compliant with: EN 50081–2, Industrial Emissions EN 50082–2, Industrial Immunity EN 61326, Meas./Control/Lab., Industrial Requirements EN 61000–6–2, Industrial Immunity C–Tick² Australian Radiocommunications Act, compliant with: AS/NZS 2064, Industrial Emissions

¹ You use this conductor category information for planning conductor routing as described in Allen-Bradley publication 1770–4.1, Industrial Automation Wiring and Grounding Guidelines.

² See the Product Certification link at www.ab.com for Declarations of Conformity, Certificates and other certification details

European Zone 2 Certification

This equipment is intended for use in potentially explosive atmospheres as defined by European Union Directive 94/9/CE.

The LCIE (Laboratoire Central des Industries Electriques) certifies that this equipment has been found to comply with the Essential Health and Safety Requirements relating to the design and construction of Category 3 equipment intended for use in potentially explosive atmospheres, given in Annex II to this Directive. The examination and test results are recorded in confidential report No. 28 682 010.

Compliance with the Essential Health and Safety Requirements has been assured by compliance with EN 50021 (1999).

IMPORTANT

Observe the following additional Zone 2 certification requirements:

- This equipment is not resistant to sunlight or other sources of UV radiation.
 - The secondary of a current transformer shall not be open-circuited.
 - The marking "ALCR" is to be considered "as applicable" to individual products.
 - Equipment of lesser Enclosure Type Rating must be installed in an enclosure providing at least IP54 protection when applied in Class I, Zone 2 environments.
 - This equipment must be powered by energy limited associated equipment as defined in EN 50021 when applied in Class I, Zone 2 environments.
 - Provision shall be made to prevent the rated voltage from being exceeded by transient disturbances of more than 40% when applied in Class I, Zone 2 environments.
-



With major offices worldwide. 

World Headquarters, Allen-Bradley
1201 South Second Street
Milwaukee, WI 53204 USA
Tel: (1) 414 382-2000 Fax: (1) 414 382-4444

1794-IN070B-EN-P - December 2001
Supersedes publication 1794-5.2 - February 1999

PN957491-36
Copyright 2001 Allen-Bradley Company, Inc. Printed in USA