

S200 UL 1077 Series Supplementary protective devices



S200

Supplementary protective devices
UL 1077 Series



Description

The S200 UL 1077 Series miniature supplementary protector offers a compact solution for protection requirements. The S200 devices are DIN rail mounted.

The S200 is available with application-specific trip characteristics to provide maximum circuit protection.

The supplementary protectors offer thermal-magnetic trip protection according to B, C, D, K and Z characteristics.

For the worldwide market, the breakers carry UL, CSA, IEC, CE and many other agency approvals and certifications.

Features

- Energy limiting
- Fast breaking time (2.3 – 2.5 ms)
- Bus connection system
- Wide range of accessories
- Available with variable depth handle mechanism
- CE certified and marked
- DIN rail mounting
- Finger safe terminals
- Multi-function terminals
- Suitable for reverse feed
- UL1077 Recognized supplemental protective device. UL file # E76126

	S200	S200P	S200PR	S280UC
Amperage	0.5 – 63 A	0.2 – 63 A	0.2 – 63A	0.2 – 63 A
Voltage	480Y/277 VAC	480Y/277 VAC	240 VAC	250/500 VDC
Poles	1, 2, 3, 4	1, 2, 3, 4	1, 2, 3, 4	1, 2, 3, 4
Trip characteristics	B, C, D, K	B, C, D, K, Z	K	K, Z
Interrupting ratings	6 kA: IEC 60898 6 kA: UL 1077 6 kA: CSA 22.2 No. 235	Up to 25kA: IEC 60947-2 10kA: UL 1077	10kA: UL1077 10kA: CSA 22.2 No.235	Up to 6kA: IEC 60947-2 10kA: UL 1077 6 kA: CSA 22.2 No. 235
Auxiliary contacts	Yes	Yes	Yes	Yes
Bell alarm	Yes	Yes	Yes	Yes
Shunt trip	Yes	Yes	Yes	Yes
Undervoltage release	Yes	Yes	Yes	Yes
Bus bar	Yes	Yes	No	Yes

S200-B, 480Y/277 VAC

Supplemental protectors
UL 1077, CSA 22.2, No. 235

B



S201-B



S203-B

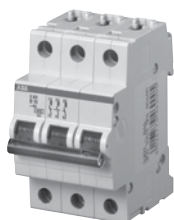

S203-B

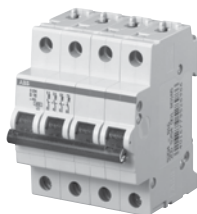

S204-B

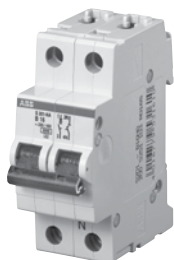

S201-BNA

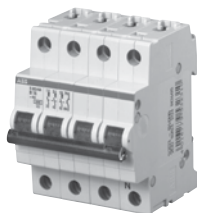

S203-BNA

No. of poles	Rated current	Catalog number	No. of poles	Rated current	Catalog number
1	6	S201-B6	3	6	S203-B6
	10	S201-B10		10	S203-B10
	13	S201-B13		13	S203-B13
	16	S201-B16		16	S203-B16
	20	S201-B20		20	S203-B20
	25	S201-B25		25	S203-B25
	32	S201-B32		32	S203-B32
	40	S201-B40		40	S203-B40
	50	S201-B50		50	S203-B50
	63	S201-B63		63	S203-B63
1 + NA	6	S201-B6NA	3 + NA	6	S203-B6NA
	10	S201-B10NA		10	S203-B10NA
	13	S201-B13NA		13	S203-B13NA
	16	S201-B16NA		16	S203-B16NA
	20	S201-B20NA		20	S203-B20NA
	25	S201-B25NA		25	S203-B25NA
	32	S201-B32NA		32	S203-B32NA
	40	S201-B40NA		40	S203-B40NA
	50	S201-B50NA		50	S203-B50NA
	63	S201-B63NA		63	S203-B63NA
2	6	S202-B6	4	6	S204-B6
	10	S202-B10		10	S204-B10
	13	S202-B13		13	S204-B13
	16	S202-B16		16	S204-B16
	20	S202-B20		20	S204-B20
	25	S202-B25		25	S204-B25
	32	S202-B32		32	S204-B32
	40	S202-B40		40	S204-B40
	50	S202-B50		50	S204-B50
	63	S202-B63		63	S204-B63

Tripping characteristic B

UL 1077
480Y/277VAC
6 kA

Resistive loads

- B Curve
- Designed for use in cable protection applications
- Example: control circuits, lighting

Accessories & technical data

Accessories – See page 15.31 - 15.34
Technical data – See page 15.35 - 15.36

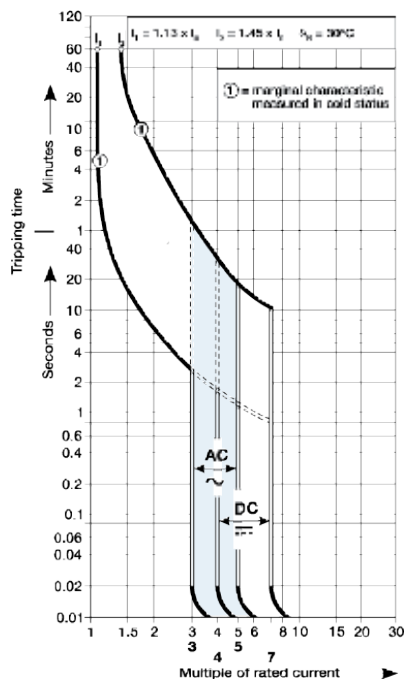

Note: Switching neutral is noted by "NA" in the catalog number.

S200-C, 480Y/277 VAC

Supplemental protectors

UL 1077, CSA 22.2, No. 235

C



S201-C



S202-C

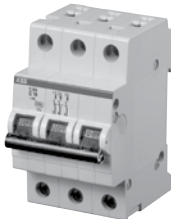

S203-C

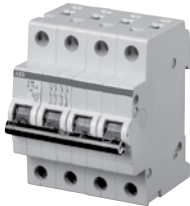

S204-C



S201-CNA

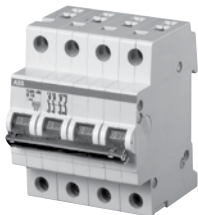

S203-CNA

No. of poles	Rated current	Catalog number	No. of poles	Rated current	Catalog number		
1	0.5	S201-C0.5	3	0.5	S203-C0.5		
	1	S201-C1		1	S203-C1		
	1.6	S201-C1.6		1.6	S203-C1.6		
	2	S201-C2		2	S203-C2		
	3	S201-C3		3	S203-C3		
	4	S201-C4		4	S203-C4		
	6	S201-C6		6	S203-C6		
	8	S201-C8		8	S203-C8		
	10	S201-C10		10	S203-C10		
	13	S201-C13		13	S203-C13		
	16	S201-C16		16	S203-C16		
	20	S201-C20		20	S203-C20		
	25	S201-C25		25	S203-C25		
	1 + NA	32		S201-C32	3 + NA	32	S203-C32
40		S201-C40	40	S203-C40			
50		S201-C50	50	S203-C50			
63		S201-C63	63	S203-C63			
0.5		S201-C0.5NA	0.5	S203-C0.5NA			
1		S201-C1NA	1	S203-C1NA			
1 + NA	1.6	S201-C1.6NA	3 + NA	1.6	S203-C1.6NA		
	2	S201-C2NA		2	S203-C2NA		
	3	S201-C3NA		3	S203-C3NA		
	4	S201-C4NA		4	S203-C4NA		
	6	S201-C6NA		6	S203-C6NA		
	8	S201-C8NA		8	S203-C8NA		
	10	S201-C10NA		10	S203-C10NA		
	13	S201-C13NA		13	S203-C13NA		
	16	S201-C16NA		16	S203-C16NA		
	20	S201-C20NA		20	S203-C20NA		
	25	S201-C25NA		25	S203-C25NA		
	32	S201-C32NA		32	S203-C32NA		
	1 + NA	40		S201-C40NA	3 + NA	40	S203-C40NA
		50		S201-C50NA		50	S203-C50NA
63		S201-C63NA	63	S203-C63NA			
0.5		S202-C0.5	4	0.5		S204-C0.5	
1		S202-C1		1		S204-C1	
1.6		S202-C1.6		1.6		S204-C1.6	
2	S202-C2	2		S204-C2			
3	S202-C3	3		S204-C3			
4	S202-C4	4		S204-C4			
6	S202-C6	6		S204-C6			
8	S202-C8	8		S204-C8			
10	S202-C10	10		S204-C10			
13	S202-C13	13		S204-C13			
16	S202-C16	16		S204-C16			
20	S202-C20	20		S204-C20			
25	S202-C25	25		S204-C25			
2	32	S202-C32		4	32	S204-C32	
	40	S202-C40	40		S204-C40		
	50	S202-C50	50		S204-C50		
	63	S202-C63	63		S204-C63		

Tripping characteristic C

UL 1077
480Y/277 VAC
6 kA

Resistive loads

- C Curve
- Designed for use with medium magnetic start up currents
- Example: lighting, control panels

Accessories & technical data

Accessories – See page 15.31 - 15.34

Technical data – See page 15.35 - 15.36

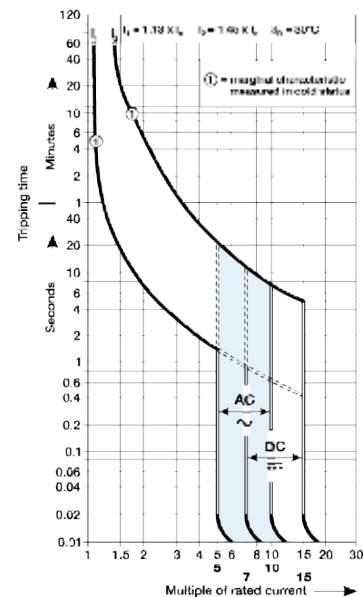

Note: Switching neutral is noted by "NA" in the catalog number.

S200-D, 480Y/277 VAC

Supplemental protectors

UL 1077, CSA 22.2, No. 235

D



S201-D



S202-D



S203-D

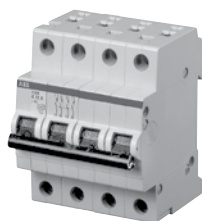

S204-D



S201-DNA

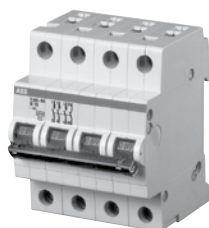

S203-DNA

No. of poles	Rated current	Catalog number	No. of poles	Rated current	Catalog number	
1	0.5	S201-D0.5	3	0.5	S203-D0.5	
	1	S201-D1		1	S203-D1	
	1.6	S201-D1.6		1.6	S203-D1.6	
	2	S201-D2		2	S203-D2	
	3	S201-D3		3	S203-D3	
	4	S201-D4		4	S203-D4	
	6	S201-D6		6	S203-D6	
	8	S201-D8		8	S203-D8	
	10	S201-D10		10	S203-D10	
	13	S201-D13		13	S203-D13	
	16	S201-D16		16	S203-D16	
	20	S201-D20		20	S203-D20	
	25	S201-D25		25	S203-D25	
		32		S201-D32	32	S203-D32
		40		S201-D40	40	S203-D40
		50		S201-D50	50	S203-D50
	63	S201-D63	63	S203-D63		
1 + NA	0.5	S201-D0.5NA	3 + NA	0.5	S203-D0.5NA	
	1	S201-D1NA		1	S203-D1NA	
	1.6	S201-D1.6NA		1.6	S203-D1.6NA	
	2	S201-D2NA		2	S203-D2NA	
	3	S201-D3NA		3	S203-D3NA	
	4	S201-D4NA		4	S203-D4NA	
	6	S201-D6NA		6	S203-D6NA	
	8	S201-D8NA		8	S203-D8NA	
	10	S201-D10NA		10	S203-D10NA	
	13	S201-D13NA		13	S203-D13NA	
	16	S201-D16NA		16	S203-D16NA	
	20	S201-D20NA		20	S203-D20NA	
	25	S201-D25NA		25	S203-D25NA	
		32		S201-D32NA	32	S203-D32NA
		40		S201-D40NA	40	S203-D40NA
		50		S201-D50NA	50	S203-D50NA
	63	S201-D63NA	63	S203-D63NA		
2	0.5	S202-D0.5	4	0.5	S204-D0.5	
	1	S202-D1		1	S204-D1	
	1.6	S202-D1.6		1.6	S204-D1.6	
	2	S202-D2		2	S204-D2	
	3	S202-D3		3	S204-D3	
	4	S202-D4		4	S204-D4	
	6	S202-D6		6	S204-D6	
	8	S202-D8		8	S204-D8	
	10	S202-D10		10	S204-D10	
	13	S202-D13		13	S204-D13	
	16	S202-D16		16	S204-D16	
	20	S202-D20		20	S204-D20	
	25	S202-D25		25	S204-D25	
		32		S202-D32	32	S204-D32
		40		S202-D40	40	S204-D40
		50		S202-D50	50	S204-D50
	63	S202-D63	63	S204-D63		

Tripping characteristic D

UL 1077
480Y/277 VAC
6 kA

Inductive loads

- D Curve
- Designed for allowing higher in-rush currents during system start up
- Example: motors, transformers

Accessories & technical data

Accessories – See page 15.31 - 15.34

Technical data – See page 15.35 - 15.36

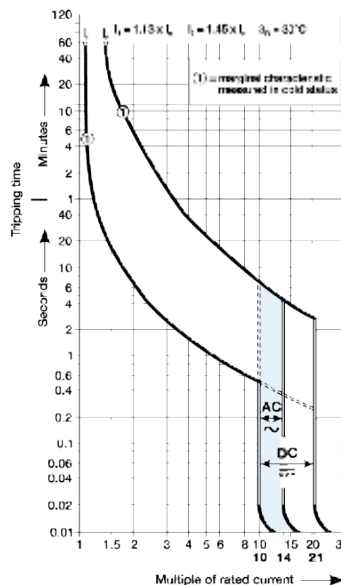

Note: Switching neutral is noted by "NA" in the catalog number.

S200-K, 480Y/277 VAC

Supplemental protectors

UL 1077, CSA 22.2, No. 235

K



S201-K



S202-K



S203-K



S204-K



S201-KNA



S203-KNA

No. of poles	Rated current	Catalog number	No. of poles	Rated current	Catalog number
1	0.5	S201-K0.5	3	0.5	S203-K0.5
	1	S201-K1		1	S203-K1
	1.6	S201-K1.6		1.6	S203-K1.6
	2	S201-K2		2	S203-K2
	3	S201-K3		3	S203-K3
	4	S201-K4		4	S203-K4
	5	S201-K5		5	S203-K5
	6	S201-K6		6	S203-K6
	8	S201-K8		8	S203-K8
	10	S201-K10		10	S203-K10
	13	S201-K13		13	S203-K13
	15	S201-K15		15	S203-K15
	16	S201-K16		16	S203-K16
	20	S201-K20		20	S203-K20
	25	S201-K25		25	S203-K25
1 + NA	0.5	S201-K0.5NA	3 + NA	0.5	S203-K0.5NA
	1	S201-K1NA		1	S203-K1NA
	1.6	S201-K1.6NA		1.6	S203-K1.6NA
	2	S201-K2NA		2	S203-K2NA
	3	S201-K3NA		3	S203-K3NA
	4	S201-K4NA		4	S203-K4NA
	6	S201-K6NA		6	S203-K6NA
	8	S201-K8NA		8	S203-K8NA
	10	S201-K10NA		10	S203-K10NA
	13	S201-K13NA		13	S203-K13NA
	16	S201-K16NA		16	S203-K16NA
	20	S201-K20NA		20	S203-K20NA
	25	S201-K25NA		25	S203-K25NA
	32	S201-K32NA		32	S203-K32NA
	40	S201-K40NA		40	S203-K40NA
50	S201-K50NA	50	S203-K50NA		
63	S201-K63NA	63	S203-K63NA		
2	0.5	S202-K0.5	4	0.5	S204-K0.5
	1	S202-K1		1	S204-K1
	1.6	S202-K1.6		1.6	S204-K1.6
	2	S202-K2		2	S204-K2
	3	S202-K3		3	S204-K3
	4	S202-K4		4	S204-K4
	5	S202-K5		5	S204-K5
	6	S202-K6		6	S204-K6
	8	S202-K8		8	S204-K8
	10	S202-K10		10	S204-K10
	13	S202-K13		13	S204-K13
	15	S202-K15		15	S204-K15
	16	S202-K16		16	S204-K16
	20	S202-K20		20	S204-K20
	25	S202-K25		25	S204-K25
32	S202-K32	32	S204-K32		
40	S202-K40	40	S204-K40		
50	S202-K50	50	S204-K50		
60	S202-K60	60	S204-K60		
63	S202-K63	63	S204-K63		

Tripping characteristic K

UL 1077
480Y/277 VAC
6 kA

Inductive loads

- K Curve
- Designed for allowing higher in-rush currents during system start up
- Example: motors, transformers

Accessories & technical data

Accessories – See page 15.31 - 15.34

Technical data – See page 15.35 - 15.36

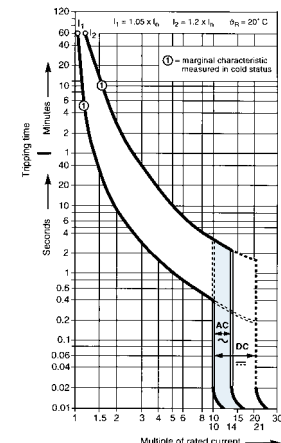

Note: Switching neutral is noted by "NA" in the catalog number.

S200-Z, 480Y/277 VAC

Supplemental protectors
UL 1077, CSA 22.2, No. 235

Z



S201-Z0.5



S202-Z0.5



S203-Z0.5



S204-Z0.5

No. of poles	Rated current	Catalog number	No. of poles	Rated current	Catalog number
1	0.5	S201-Z0.5	3	0.5	S203-Z0.5
	1	S201-Z1		1	S203-Z1
	1.6	S201-Z1.6		1.6	S203-Z1.6
	2	S201-Z2		2	S203-Z2
	3	S201-Z3		3	S203-Z3
	4	S201-Z4		4	S203-Z4
	6	S201-Z6		6	S203-Z6
	10	S201-Z10		10	S203-Z10
	13	S201-Z13		13	S203-Z13
	16	S201-Z16		16	S203-Z16
	20	S201-Z20		20	S203-Z20
	25	S201-Z25		25	S203-Z25
	32	S201-Z32		32	S203-Z32
2	0.5	S202-Z0.5	4	0.5	S204-Z0.5
	1	S202-Z1		1	S204-Z1
	1.6	S202-Z1.6		1.6	S204-Z1.6
	2	S202-Z2		2	S204-Z2
	3	S202-Z3		3	S204-Z3
	4	S202-Z4		4	S204-Z4
	6	S202-Z6		6	S204-Z6
	10	S202-Z10		10	S204-Z10
	13	S202-Z13		13	S204-Z13
	16	S202-Z16		16	S204-Z16
	20	S202-Z20		20	S204-Z20
	25	S202-Z25		25	S204-Z25
	32	S202-Z32		32	S204-Z32
40	S202-Z40	40	S204-Z40		
50	S202-Z50	50	S204-Z50		
63	S202-Z63	63	S204-Z63		

Tripping characteristic Z

UL 1077
480Y/277VAC
6 kA

Resistive loads

- Z Curve
- Designed to provide maximum protection with a very low short circuit trip setting
- Example: semiconductors

Accessories & technical data

Accessories – See page 15.31 - 15.34

Technical data – See page 15.35 - 15.36

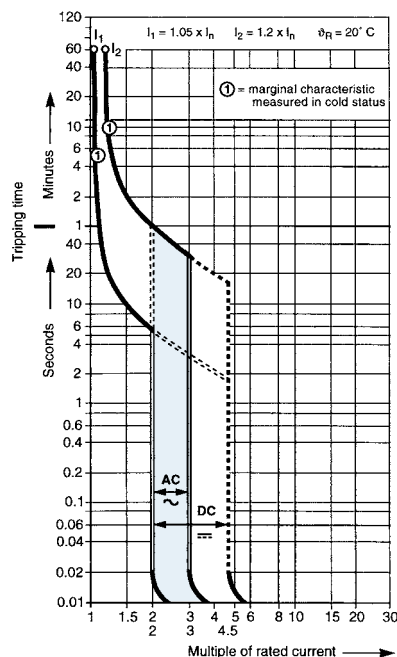

S200P-B, 480Y/277 VAC
Supplemental protectors
UL 1077, CSA 22.2, No. 235

B



S210P-B6



S210P-B6



S210P-B6



S210P-B6

No. of poles	Rated current	Catalog number	No. of poles	Rated current	Catalog number
1	6	S201P-B6	3	6	S203P-B6
	10	S201P-B10		10	S203P-B10
	13	S201P-B13		13	S203P-B13
	16	S201P-B16		16	S203P-B16
	20	S201P-B20		20	S203P-B20
	25	S201P-B25		25	S203P-B25
	32	S201P-B32		32	S203P-B32
	40	S201P-B40		40	S203P-B40
	50	S201P-B50		50	S203P-B50
2	6	S202P-B6	4	6	S204P-B6
	10	S202P-B10		10	S204P-B10
	13	S202P-B13		13	S204P-B13
	16	S202P-B16		16	S204P-B16
	20	S202P-B20		20	S204P-B20
	25	S202P-B25		25	S204P-B25
	32	S202P-B32		32	S204P-B32
	40	S202P-B40		40	S204P-B40
	50	S202P-B50		50	S204P-B50
	63	S202P-B63	63	S204P-B63	

Tripping characteristic B

UL 1077
480Y/277 VAC
10 kA

Resistive loads

- B Curve
- Designed for use in cable protection applications
- Example: Control circuits, lighting

Accessories & technical data

Accessories – See page 15.31 - 15.34

Technical data – See page 15.35 - 15.36

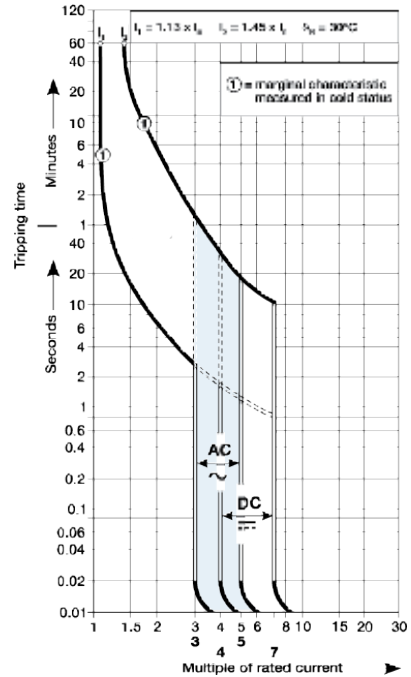

S200P-C, 480Y/277 VAC

Supplemental protectors

UL 1077, CSA 22.2, No. 235

C



S210P-B6



S210P-B6

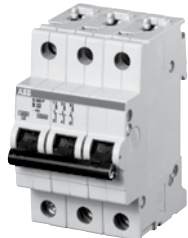

S210P-B6

No. of poles	Rated current	Catalog number	No. of poles	Rated current	Catalog number
1	0.5	S201P-C0.5	3	0.5	S203P-C0.5
	1	S201P-C1		1	S203P-C1
	1.6	S201P-C1.6		1.6	S203P-C1.6
	2	S201P-C2		2	S203P-C2
	3	S201P-C3		3	S203P-C3
	4	S201P-C4		4	S203P-C4
	6	S201P-C6		6	S203P-C6
	8	S201P-C8		8	S203P-C8
	10	S201P-C10		10	S203P-C10
	13	S201P-C13		13	S203P-C13
	16	S201P-C16		16	S203P-C16
	20	S201P-C20		20	S203P-C20
	2	0.5		S202P-C0.5	
1		S202P-C1	1	S203P-C1	
1.6		S202P-C1.6	1.6	S203P-C1.6	
2		S202P-C2	2	S203P-C2	
3		S202P-C3	3	S203P-C3	
4		S202P-C4	4	S203P-C4	
6		S202P-C6	6	S203P-C6	
8		S202P-C8	8	S203P-C8	
10		S202P-C10	10	S203P-C10	
13		S202P-C13	13	S203P-C13	
16		S202P-C16	16	S203P-C16	
20		S202P-C20	20	S203P-C20	
25		S202P-C25	25	S203P-C25	
32	S202P-C32	32	S203P-C32		
40	S202P-C40	40	S203P-C40		
50	S202P-C50	50	S203P-C50		
63	S202P-C63	63	S203P-C63		

Tripping characteristic C

UL 1077
480Y/277 VAC
10 kA

Resistive loads

- C Curve
- Designed for use with medium magnetic start up currents
- Example: Lighting, control panels

Accessories & technical data

Accessories – See page 15.31 - 15.34

Technical data – See page 15.35 - 15.36

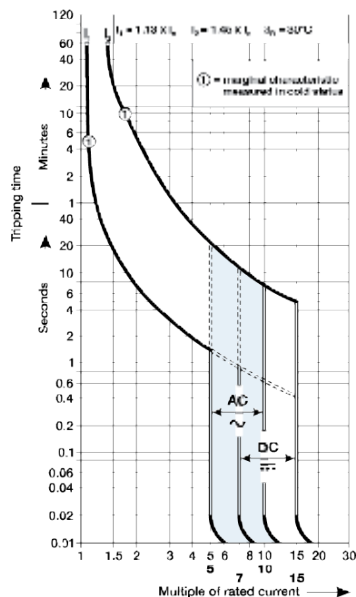

S200P-D, 480Y/277 VAC

Supplemental protectors

UL 1077, CSA 22.2, No. 235

D



S201P-D0.5



S202P-D0.5

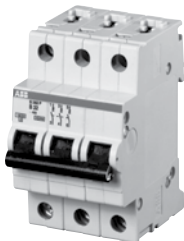

S203P-D0.5

No. of poles	Rated current	Catalog number	No. of poles	Rated current	Catalog number
1	0.5	S201P-D0.5	3	0.5	S203P-D0.5
	1	S201P-D1		1	S203P-D1
	1.6	S201P-D1.6		1.6	S203P-D1.6
	2	S201P-D2		2	S203P-D2
	3	S201P-D3		3	S203P-D3
	4	S201P-D4		4	S203P-D4
	6	S201P-D6		6	S203P-D6
	8	S201P-D8		8	S203P-D8
	10	S201P-D10		10	S203P-D10
	13	S201P-D13		13	S203P-D13
	16	S201P-D16		16	S203P-D16
	20	S201P-D20		20	S203P-D20
	25	S201P-D25		25	S203P-D25
	32	S201P-D32		32	S203P-D32
40	S201P-D40	40	S203P-D40		
50	S201P-D50	50	S203P-D50		
63	S201P-D63	63	S203P-D63		
2	0.5	S202P-D0.5			
	1	S202P-D1			
	1.6	S202P-D1.6			
	2	S202P-D2			
	3	S202P-D3			
	4	S202P-D4			
	6	S202P-D6			
	8	S202P-D8			
	10	S202P-D10			
	13	S202P-D13			
	16	S202P-D16			
	20	S202P-D20			
	25	S202P-D25			
	32	S202P-D32			
40	S202P-D40				
50	S202P-D50				
63	S202P-D63				

Tripping characteristic D

UL 1077
480Y/277 VAC
10 kA

Inductive loads

- D Curve
- Designed for allowing higher in-rush currents during system start up
- Example: motors, transformers

Accessories & technical data

Accessories – See page 15.31 - 15.34

Technical data – See page 15.35 - 15.36

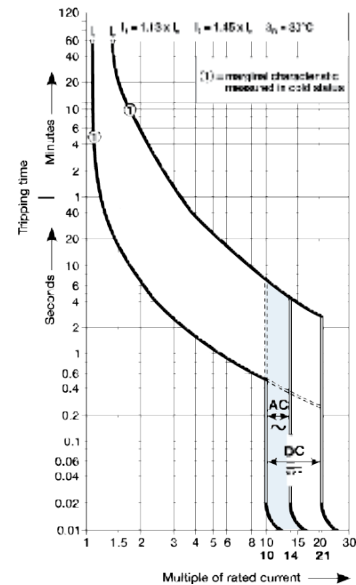

S200P-K, 480Y/277 VAC

Supplemental protectors

UL 1077, CSA 22.2, No. 235

K



S201P-K



S202P-K

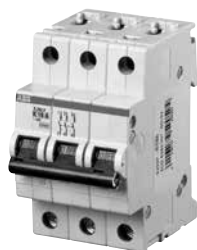

S203P-K

No. of poles	Rated current	Catalog number	No. of poles	Rated current	Catalog number
1	0.2	S201P-K0.2	3	0.2	S203P-K0.2
	0.3	S201P-K0.3		0.3	S203P-K0.3
	0.5	S201P-K0.5		0.5	S203P-K0.5
	0.75	S201P-K0.75		0.75	S203P-K0.75
	1	S201P-K1		1	S203P-K1
	1.6	S201P-K1.6		1.6	S203P-K1.6
	2	S201P-K2		2	S203P-K2
	3	S201P-K3		3	S203P-K3
	4	S201P-K4		4	S203P-K4
	6	S201P-K6		6	S203P-K6
	8	S201P-K8		8	S203P-K8
	10	S201P-K10		10	S203P-K10
	13	S201P-K13		13	S203P-K13
	16	S201P-K16		16	S203P-K16
20	S201P-K20	20	S203P-K20		
25	S201P-K25	25	S203P-K25		
32	S201P-K32	32	S203P-K32		
2	40	S201P-K40	3	40	S203P-K40
	50	S201P-K50		50	S203P-K50
	63	S201P-K63		63	S203P-K63
	0.2	S202P-K0.2		0.2	S202P-K0.2
	0.3	S202P-K0.3		0.3	S202P-K0.3
	0.5	S202P-K0.5		0.5	S202P-K0.5
	0.75	S202P-K0.75		0.75	S202P-K0.75
	1	S202P-K1		1	S202P-K1
	1.6	S202P-K1.6		1.6	S202P-K1.6
	2	S202P-K2		2	S202P-K2
3	S202P-K3	3	S202P-K3		
4	S202P-K4	4	S202P-K4		
6	S202P-K6	6	S202P-K6		
8	S202P-K8	8	S202P-K8		
10	S202P-K10	10	S202P-K10		
13	S202P-K13	13	S202P-K13		
16	S202P-K16	16	S202P-K16		
20	S202P-K20	20	S202P-K20		
25	S202P-K25	25	S202P-K25		
32	S202P-K32	32	S202P-K32		
40	S202P-K40	40	S202P-K40		
50	S202P-K50	50	S202P-K50		
63	S202P-K63	63	S202P-K63		

Tripping characteristic K

UL 1077
480Y/277 VAC
10 kA

Inductive loads

- K Curve
- Designed for allowing higher in-rush currents during system start up
- Example: motors, transformers

Accessories & technical data

Accessories – See page 15.31 - 15.34

Technical data – See page 15.35 - 15.36

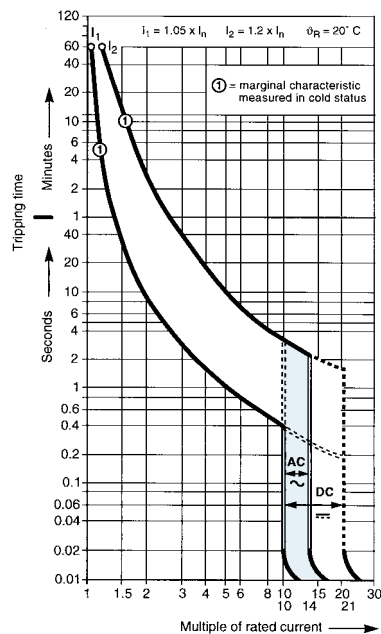

S200P-Z, 480Y/277 VAC

Supplemental protectors
UL 1077, CSA 22.2, No. 235

Z



S201P-Z



S202P-Z



S203P-Z

No. of poles	Rated current	Catalog number	No. of poles	Rated current	Catalog number		
1	0.5	S201P-Z0.5	3	0.5	S203P-Z0.5		
	1	S201P-Z1		1	S203P-Z1		
	1.6	S201P-Z1.6		1.6	S203P-Z1.6		
	2	S201P-Z2		2	S203P-Z2		
	3	S201P-Z3		3	S203P-Z3		
	4	S201P-Z4		4	S203P-Z4		
	6	S201P-Z6		6	S203P-Z6		
	8	S201P-Z8		8	S203P-Z8		
	10	S201P-Z10		10	S203P-Z10		
	16	S201P-Z16		16	S203P-Z16		
	20	S201P-Z20		20	S203P-Z20		
	25	S201P-Z25		25	S203P-Z25		
	2	32		S201P-Z32	3	32	S203P-Z32
		40		S201P-Z40		40	S203P-Z40
50		S201P-Z50	50	S203P-Z50			
63		S201P-Z63	63	S203P-Z63			
0.5		S202P-Z0.5	2	0.5		S202P-Z0.5	
1		S202P-Z1		1		S202P-Z1	
1.6		S202P-Z1.6		1.6		S202P-Z1.6	
2		S202P-Z2		2		S202P-Z2	
3		S202P-Z3		3		S202P-Z3	
4		S202P-Z4		4		S202P-Z4	
6	S202P-Z6	6		S202P-Z6			
8	S202P-Z8	8		S202P-Z8			
10	S202P-Z10	10		S202P-Z10			
16	S202P-Z16	16		S202P-Z16			
20	S202P-Z20	20		S202P-Z20			
25	S202P-Z25	25		S202P-Z25			
2	32	S202P-Z32		2	32	S202P-Z32	
	40	S202P-Z40			40	S202P-Z40	
	50	S202P-Z50	50		S202P-Z50		
	63	S202P-Z63	63		S202P-Z63		

Tripping characteristic Z

UL 1077
480Y/277 VAC
10 kA

Resistive loads

- Z Curve
- Designed to provide maximum protection with a very low short circuit trip setting
- Example: semiconductors

Accessories & technical data

Accessories – See page 15.31 - 15.34

Technical data – See page 15.35 - 15.36

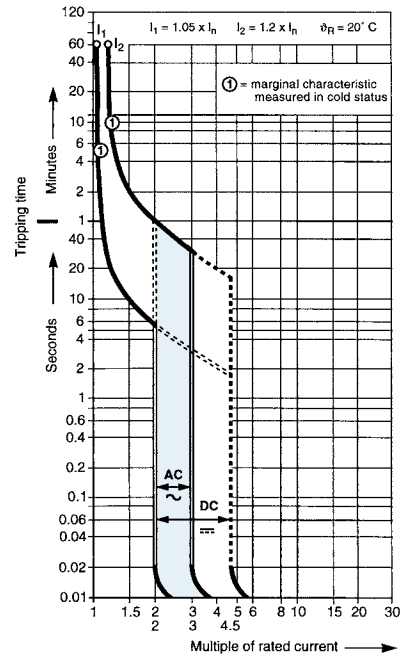

S200PR-K, 240 VAC, Ring tongue

Supplemental protectors

UL1077, CSA 22.2 No. 235

K



S201PR-K0.2



S202PR-K0.2



S203PR-K0.2



S203PR-K0.2

No. of poles	Rated current	Catalog number	No. of poles	Rated current	Catalog number
1	0.2	S201PR-K0.2	3	0.2	S203PR-K0.2
	0.3	S201PR-K0.3		0.3	S203PR-K0.3
	0.5	S201PR-K0.5		0.5	S203PR-K0.5
	0.75	S201PR-K0.75		0.75	S203PR-K0.75
	1	S201PR-K1		1	S203PR-K1
	1.6	S201PR-K1.6		1.6	S203PR-K1.6
	2	S201PR-K2		2	S203PR-K2
	3	S201PR-K3		3	S203PR-K3
	4	S201PR-K4		4	S203PR-K4
	5	S201PR-K5		5	S203PR-K5
	6	S201PR-K6		6	S203PR-K6
	8	S201PR-K8		8	S203PR-K8
	10	S201PR-K10		10	S203PR-K10
	13	S201PR-K13		13	S203PR-K13
	15	S201PR-K15		15	S203PR-K15
	16	S201PR-K16		16	S203PR-K16
	20	S201PR-K20		20	S203PR-K20
25	S201PR-K25	25	S203PR-K25		
30	S201PR-K30	30	S203PR-K30		
32	S201PR-K32	32	S203PR-K32		
35	S201PR-K35	35	S203PR-K35		
40	S201PR-K40	40	S203PR-K40		
50	S201PR-K50	50	S203PR-K50		
60	S201PR-K60	60	S203PR-K60		
63	S201PR-K63	63	S203PR-K63		
2	0.2	S202PR-K0.2	4	0.2	S204PR-K0.2
	0.3	S202PR-K0.3		0.3	S204PR-K0.3
	0.5	S202PR-K0.5		0.5	S204PR-K0.5
	0.75	S202PR-K0.75		0.75	S204PR-K0.75
	1	S202PR-K1		1	S204PR-K1
	1.6	S202PR-K1.6		1.6	S204PR-K1.6
	2	S202PR-K2		2	S204PR-K2
	3	S202PR-K3		3	S204PR-K3
	4	S202PR-K4		4	S204PR-K4
	5	S202PR-K5		5	S204PR-K5
	6	S202PR-K6		6	S204PR-K6
	8	S202PR-K8		8	S204PR-K8
	10	S202PR-K10		10	S204PR-K10
	13	S202PR-K13		13	S204PR-K13
	15	S202PR-K15		15	S204PR-K15
	16	S202PR-K16		16	S204PR-K16
	20	S202PR-K20		20	S204PR-K20
25	S202PR-K25	25	S204PR-K25		
30	S202PR-K30	30	S204PR-K30		
32	S202PR-K32	32	S204PR-K32		
35	S202PR-K35	35	S204PR-K35		
40	S202PR-K40	40	S204PR-K40		
50	S202PR-K50	50	S204PR-K50		
60	S202PR-K60	60	S204PR-K60		
63	S202PR-K63	63	S204PR-K63		

Tripping characteristic K

UL 1077

480Y/277 VAC

10 kA

Inductive loads

- K Curve
- Designed for allowing higher in-rush currents during system start up
- Example: motors, transformers

Accessories & technical data

Accessories – See page 15.31 - 15.34

Technical data – See page 15.35 - 15.36

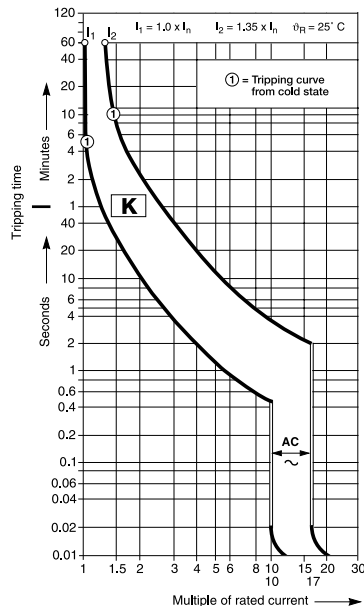

S280UC-K, 500 VDC

Supplemental protectors

UL 1077, CSA 22.2, No. 235

K



S281UC-K



S282UC-K



S283UC-K

No. of poles	Rated current	Catalog number	No. of poles	Rated current	Catalog number
1	0,2	S281UC-K0.2	3	0,2	S283UC-K0.2
	0,3	S281UC-K0.3		0,3	S283UC-K0.3
	0,5	S281UC-K0.5		0,5	S283UC-K0.5
	0,75	S281UC-K0.75		0,75	S283UC-K0.75
	1	S281UC-K1		1	S283UC-K1
	1,6	S281UC-K1.6		1,6	S283UC-K1.6
	2	S281UC-K2		2	S283UC-K2
	3	S281UC-K3		3	S283UC-K3
	4	S281UC-K4		4	S283UC-K4
	6	S281UC-K6		6	S283UC-K6
	8	S281UC-K8		8	S283UC-K8
	10	S281UC-K10		10	S283UC-K10
	16	S281UC-K16		16	S283UC-K16
	20	S281UC-K20		20	S283UC-K20
	25	S281UC-K25		25	S283UC-K25
2	32	S281UC-K32	3	32	S283UC-K32
	40	S281UC-K40		40	S283UC-K40
	50	S281UC-K50		50	S283UC-K50
	63	S281UC-K63		63	S283UC-K63
	0,2	S282UC-K0.2		0,2	S282UC-K0.2
	0,3	S282UC-K0.3		0,3	S282UC-K0.3
	0,5	S282UC-K0.5		0,5	S282UC-K0.5
	0,75	S282UC-K0.75		0,75	S282UC-K0.75
	1	S282UC-K1		1	S282UC-K1
	1,6	S282UC-K1.6		1,6	S282UC-K1.6
2	S282UC-K2	2	S282UC-K2		
3	S282UC-K3	3	S282UC-K3		
4	S282UC-K4	4	S282UC-K4		
6	S282UC-K6	6	S282UC-K6		
8	S282UC-K8	8	S282UC-K8		
10	S282UC-K10	10	S282UC-K10		
16	S282UC-K16	16	S282UC-K16		
20	S282UC-K20	20	S282UC-K20		
25	S282UC-K25	25	S282UC-K25		
32	S282UC-K32	32	S282UC-K32		
40	S282UC-K40	40	S282UC-K40		
50	S282UC-K50	50	S282UC-K50		
63	S282UC-K63	63	S282UC-K63		

Tripping characteristic K

UL 1077
250/500 VDC
10 kA

Inductive loads

- K Curve
- Designed for allowing higher in-rush currents during system start up
- Example: motors, transformer

Accessories & technical data

Accessories – See page 15.31 - 15.34

Technical data – See page 15.35 - 15.36

Direct current applications

The S280UC differs from standard miniature circuit breakers in that the UC versions include a permanent magnet which aids in the extinguishing of the arc during medium and high level faults. It is necessary to observe the correct polarity and current direction when connecting the UC breakers. Two examples of correct connection are shown.

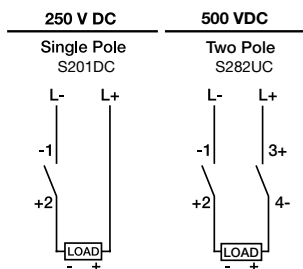

Termination points are marked on all UC type MCBs, points one (1) and four (4) are negative and points two (2) and three (3) are positive.

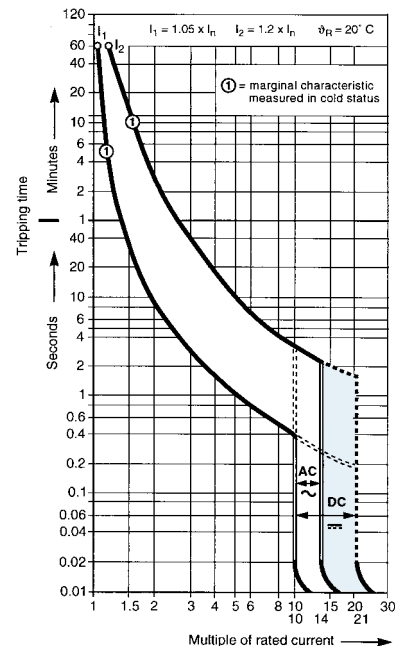

S280UC-Z, 500 VDC

Supplemental protectors

UL 1077, CSA 22.2, No. 235

Z



S281UC-Z



S282UC-Z



S283UC-Z

No. of poles	Rated current	Catalog number	No. of poles	Rated current	Catalog number
1	0.5	S281UC-Z0.5	3	0.5	S283UC-Z0.5
	1	S281UC-Z1		1	S283UC-Z1
	1.6	S281UC-Z1.6		1.6	S283UC-Z1.6
	2	S281UC-Z2		2	S283UC-Z2
	3	S281UC-Z3		3	S283UC-Z3
	4	S281UC-Z4		4	S283UC-Z4
	6	S281UC-Z6		6	S283UC-Z6
	8	S281UC-Z8		8	S283UC-Z8
	10	S281UC-Z10		10	S283UC-Z10
	16	S281UC-Z16		16	S283UC-Z16
	20	S281UC-Z20		20	S283UC-Z20
	25	S281UC-Z25		25	S283UC-Z25
	32	S281UC-Z32		32	S283UC-Z32
	40	S281UC-Z40		40	S283UC-Z40
50	S281UC-Z50	50	S283UC-Z50		
63	S281UC-Z63	63	S283UC-Z63		
2	0.5	S282UC-Z0.5			
	1	S282UC-Z1			
	1.6	S282UC-Z1.6			
	2	S282UC-Z2			
	3	S282UC-Z3			
	4	S282UC-Z4			
	6	S282UC-Z6			
	8	S282UC-Z8			
	10	S282UC-Z10			
	16	S282UC-Z16			
	20	S282UC-Z20			
	25	S282UC-Z25			
	32	S282UC-Z32			
	40	S282UC-Z40			
50	S282UC-Z50				
63	S282UC-Z63				

Tripping characteristic Z

UL 1077
250/500 VDC
10 kA

Resistive loads

- Z Curve
- Designed to provide maximum protection with a very low short circuit trip setting
- Example: semiconductors

Accessories & technical data

Accessories – See page 15.31 - 15.34

Technical data – See page 15.35 - 15.36

Direct current applications

The S280UC differs from standard miniature circuit breakers in that the UC versions include a permanent magnet which aids in the extinguishing of the arc during medium and high level faults. It is necessary to observe the correct polarity and current direction when connecting the UC breakers. Two examples of correct connection are shown.

Termination points are marked on all UC type MCBs, points one (1) and four (4) are negative and points two (2) and three (3) are positive.

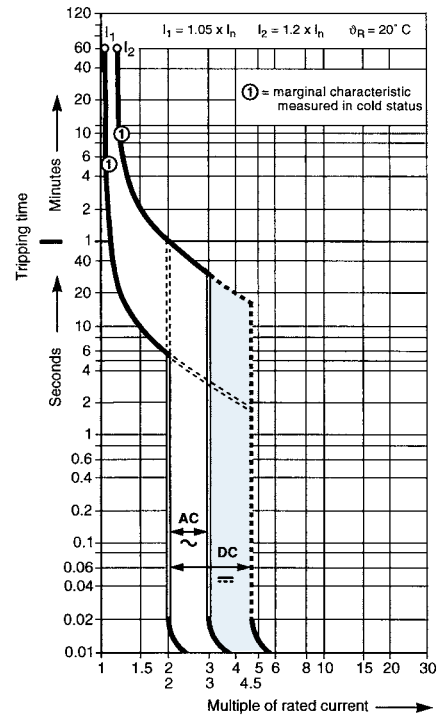
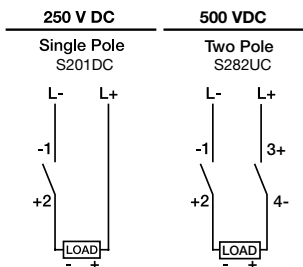

Accessories

S200, S200P & S200PR

UL 1077, CSA 22.2, No. 235

Auxiliary contacts

The auxiliary contacts will signal whether the breaker is in the ON or OFF position.

Description	Catalog number
For field mounting: right side	S2C-H6R



S2C-H6R

Bell alarm - signal contact

The bell alarm includes a set of contacts that will only signal when the breaker has tripped.

Typically the contacts would be connected to an alarm or bell to signal the operator that an overcurrent trip has occurred. The bell alarm also includes a test button for testing the alarm contacts without opening the breaker.

Description	Catalog number
For field mounting: right side	S2C-S/H6R ①

Shunt trip

For remote tripping of breaker, a shunt trip device can be added to the MCB. The solenoid device opens the breaker after control voltage is applied.

Description	Catalog number
For field mounting: right side	
A1-12-60 VAC (12 – 60 VDC)	S2C-A1
A2-110-415 VAC (110 – 250 VDC)	S2C-A2



S2C-A

Undervoltage release

When control voltage drops below approximately 50 % of rated voltage, the UVR opens the breaker. The breaker can not be operated unless proper control voltage is first applied to the UVR coil.

Description	Catalog number
For field mounting: right side	
12 VDC	S2C-UA 12
24 VAC/VDC	S2C-UA 24
48 VAC/VDC	S2C-UA 48
110 VAC/VDC	S2C-UA 110
220 VAC/VDC	S2C-UA 230
380 VAC	S2C-UA 400



S2C-UA



SA 1



SA 2

Possible mounting arrangements of MCB accessories

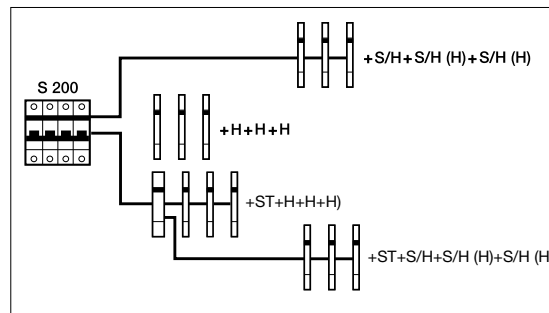

Legend	
Auxiliary contact	H
Bell alarm/Auxiliary contact	S/H
Bell alarm/Auxiliary contact used as auxiliary contact	S/H (H)
Shunt trip	ST
Undervoltage release	UR

Locking devices

Description	Catalog number
Locking devices, 3 mm	SA1
Padlock with 2 keys	SA2

① Combination bell alarm/auxiliary contact.

Accessories

S200PR

UL 1077, CSA 22.2, No. 235

S200PR Accessory overview

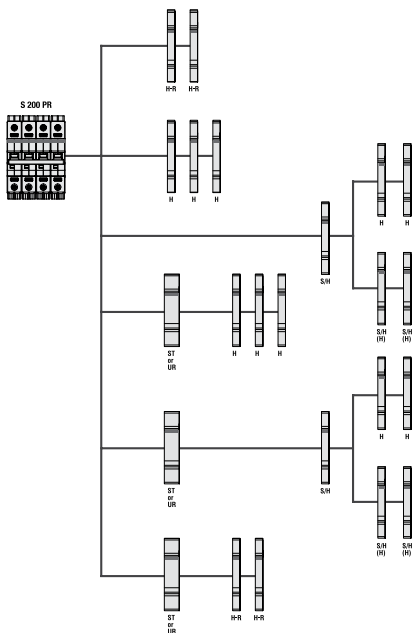

- H Auxiliary contact S2C-H6R
- H-R Auxiliary contact S2C-H6-...R
- S/H Signal/Auxiliary contact S2C-S/H6R
- S/H (H) Signal/Auxiliary contact S2C-S/H6R used as auxiliary contact
- ST Shunt trip S2C-A...
- UR Undervoltage release S2C-UA

S200PR Instructions for use

Ring Tongue Details

Only or ring cable lugs	Insulated only Rated voltage 480V/277 V AC	A	B	C
	Insulated only Rated voltage 240/240 V AC	max. 11.0 mm (0.43")	max. 12.2 mm (0.48")	Suitable for M5 (0.20")
		A	B	C
		max. 14.0 mm (0.55")	max. 12.2 mm (0.48")	Suitable for M5 (0.20")

CU only
 60/75°C
 (140/167°F)

max. 2.0 mm
 (0.08")

PZ 2 Torque: 2.8 Nm (25lb-in)

Ring Tongue Terminal, Special purpose - Not for general use

Installation Instructions

Please insert or withdraw the cable lug only when the screw is completely open.

Please make sure that the terminal screw penetrates the ring lug hole properly and completely during tightening.

Please ensure that the screw is securely tightened before applying any mechanical force on the cable / cable lug.

Do not apply abnormal downward pressure on the screw during tightening or loosening of the screw.

F = max. 30 N F = Maximum to operate

Please follow the Ring Tongue Details on the rear of this sheet.

Accessories

S280UC

UL 1077, CSA 22.2, No. 235



S2-A1

Shunt trips

Function: remote opening of the device when a voltage is applied
Suitable for MCBs S 280 and S 280 UC series.

Description	Catalog number
12-60 VAC/VDC shunt trip	S2-A1
110-415 VAC and 110-250 VDC shunt trip	S2-A2

S2-A1 I
S2-A2 I

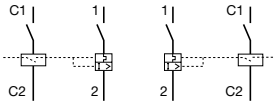

Auxiliary contacts

Function: indication of the position of the device's contacts
Suitable for MCBs S 280 and S 280 UC series

Signal contacts

Function: indication of the position of the device's contacts only after the automatic release of the MCBs and RCBOs due to an overload or a short-circuit
Suitable for MCBs S 280 and S 280 UC series

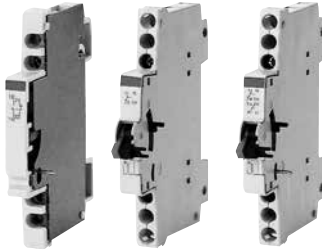

Description	Catalog number
Auxiliary contact 1 NO + 1 NC (1/2 module)	S2-H11
Auxiliary contact 2 NO (1/2 module)	S2-H20
Auxiliary contact 2 NC (1/2 module)	S2-H02
Auxiliary contact 1 NO + 1 NC (1/2 module) with Faston connections	S2-H11X
Auxiliary contact 2 NO (1/2 module) with Faston connections	S2-H20X
Auxiliary contact 2 NC (1/2 module) with Faston connections	S2-H02X
Auxiliary contact 2 NO + 1 NC (1/2 module)	S2-H21
Auxiliary contact 1 NO + 2 NC (1/2 module)	S2-H12
Auxiliary contact 3 NO (1/2 module)	S2-H30
Auxiliary contact 3 NC (1/2 module)	S2-H03
Signal contact (1/2 module)	S2-S
Signal contact + Auxiliary contact (1/2 module)	S2-S/H

Undervoltage release

Function: protection of the load in the event of a voltage drop (between 70% and 35% of its rated value); positive safety (device's tripping when the voltage is disconnected) emergency stop by means of a button.
Suitable for MCBs S 280 and S 280 UC series.



S2-UA12

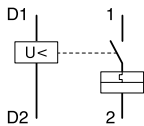

Description	Catalog number
Undervoltage release 12V DC (1 module)	S2-UA12
Undervoltage release 24V AC/DC (1 module)	S2-UA24
Undervoltage release 48V AC/DC (1 module)	S2-UA48
Undervoltage release 110V AC/DC (1 module)	S2-UA110
Undervoltage release 220V AC/DC (1 module)	S2-UA220
Undervoltage release 380V AC (1 module)	S2-UA380

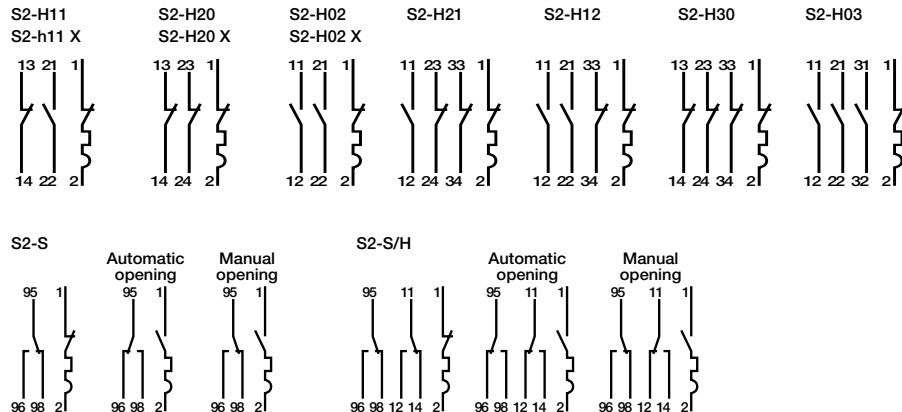

Accessories

S280UC

UL 1077, CSA 22.2, No. 235

Hand operated neutral

The hand operated neutral has to be mounted to the left side of the MCB and be snapped on the DIN rail. It is used for measuring duties where the neutral conductor must be in the open position. Due to the special design of the handle - when switching ON the MCB – the neutral will make before the MCB is closed. The S2C - Nt is not to switch with a tool (screw driver).

Description	Catalog number
Hand operated neutral	S2-NT

Schemes for combination and technical features

Auxiliary elements for MCBs S 280 series

Miniature
circuit breakers
S200

Combination between auxiliary elements and S 280

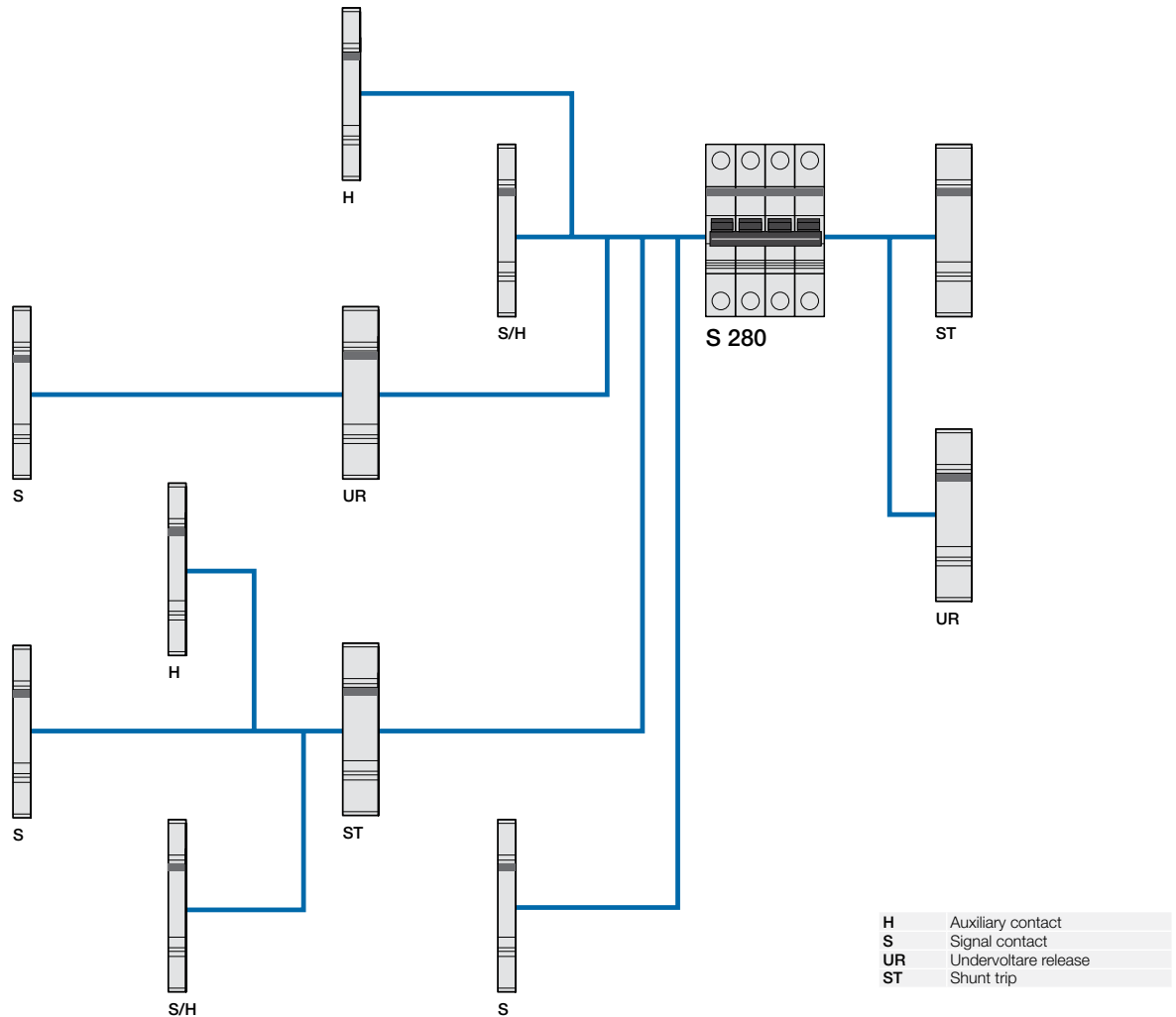

Technical characteristics of auxiliary and signal contacts

Type		S2-H11 I S2-H11 X	S2-H20 I S2-H20 X	S2-H02 I S2-H02 X	S2-H21	S2-H12	S2-H30	S2-H03
Description		1NO+1NC	2NO	2NC	2NO+1NC	1NO+2NC	3NO	3NC
Alternating current	Ue [V] Ie [A]				240 6	415 2		
Direct current	Ue [V] Ie [A]			24 4	60 2	110 1.5	250 1	
Min. operating voltage	[V]				12 a.c.-12 d.c.			
Min. operating current	[mA]				12			
Terminals	[mm ²]				up to 2x1.5			
Dielectric strength	[kV]				3			
Resistance to short-circuit at 240 V a.c.	[A]				1000 (protected with S 2 breaker characteristic K - 6 A)			
Impulse voltage withstand capacity	[kV]				4			
Tightening torque	[Nm]				0.7			
Dimensions (WxDxH)	[mm]				8.75x68x90			

NB: the auxiliary contacts S2-H11 X, S2-H20 X, S2-H02 X differ from the contacts S2-H11, S2-H20, S2-H02 in that they do not have a terminal to tighten the cable which is replaced by a bayonet for the Faston connection.

Technical features

Auxiliary elements for MCBs S 280 series

Technical characteristics of shunt trips

Type		S2-A1	S2-A2
Rated voltage	[V] a.c.	12 - 60	110 - 415
	d.c.	12 - 60	110 - 250
Max. release duration	[ms]	<10	<10
Min. release voltage	[V] a.c.	7	55
	d.c.	10	80
Consumption on release	[VA] 12 V a.c.	35	
	12 V d.c.	30	
	24 V a.c.	140	
	24 V d.c.	100	
	48 V a.c.	600	
	48 V d.c.	330	
	110 V a.c.		40
	110 V d.c.		40
	220 V a.c.		180
	220 V d.c.		170
Coil resistance	[Ω]	3.7	225
Terminals	[mm ²]	25	25
Tightening torque	[Nm]	2	2
Dimens.(WxDxH)	[mm]	17.5x68x90	17.5x68x90

Technical characteristics of undervoltage releases

Type		S2-UA 12	S2-UA 24	S2-UA 48	S2-UA 110	S2-UA 220	S2-UA 380
Standards		VDE0660 part I - IEC EN 60947.1					
Rated voltage	[V] a.c.	-	24	48	110	220-240	380
	[V] d.c.	12	24	-	110	220-240	380
Frequency	[Hz]	50...60					
Release trip	[V]	0.35 Un ≤ V ≤ 0.7 Un					
Terminals	[mm ²]	2 x 1.5					
Consumption	[mA]	10					
Resistance to corrosion	[°C/RH]	const. climatic cond.: 23/83-40/93-55/20; var. climatic cond.: 25/95-40/93					
Protection degree		IP20					
Tightening torque	[Nm]	0.4					
Dimensions (WxDxH)	[mm]	17.5x68x90					

S2-S

S2-SH

1 change over	2 change over
	240
	415
	6
	2
250	110
0.5	60
	24
	1
	1
	4
12 a.c.-12 d.c.	
12	
up to 2x1.5	
3	
1000 (protected with S 2 breaker characteristic K - 6 A)	
4	
0.7	
8.75x68x90	

Accessories

S200 & S200P

UL 1077, CSA 22.2, No. 235 (suitable for cutting)

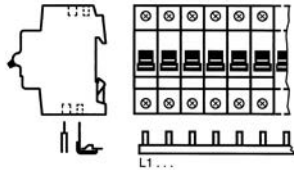

1 Phase

1 Phase

For use on:	Amp rating	Number of poles	Phases	Busbar length (mm)	End cap catalog number	Catalog number
S200	63	60	1	986	PS-END0	PS1/60SP
S200 P	80	60	1	986	PS-END0	PS1/60/16SP

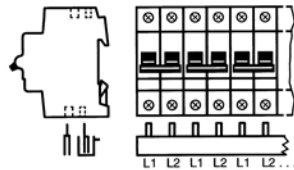

2 Phase

2 Phase

For use on:	Amp rating	Number of poles	Phases	Busbar length (mm)	End cap catalog number	Catalog number
S200	63	58	2	1035	PS-ENDSP	PS2/58SP
S200 P	80	58	2	1035	PS-ENDSP	PS2/58/16SP

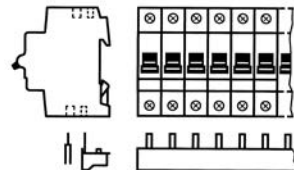

3 Phase

3 Phase

For use on:	Amp rating	Number of poles	Phases	Busbar length (mm)	End cap catalog number	Catalog number
S200	63	60	3	1065	PSB-ENDSP	PS3/60SP
S200 P	80	60	3	1065	PSB-ENDSP	PS3/60/16SP

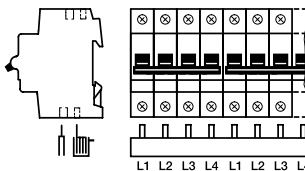

4 Phase

4 Phase

For use on:	Amp rating	Number of poles	Phases	Busbar length (mm)	End cap catalog number	Catalog number
S200	80	60	4	1056	PS-END1	PS4/60/16SP

NOTE

ALL BUSBARS MAY BE CENTER FED IN ORDER TO INCREASE AMPACITY UP TO 130 A.

NOTE

BUSBARS MAY BE USED ON LINE OR LOAD SIDE OF MCBS

Accessories

S200 & S200P

UL 1077, CSA 22.2, No. 235

1 Phase with 1 auxiliary

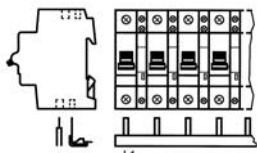

1 Phase + Aux

For use on:	Amp rating	Number of poles	Phases	Busbar length (mm)	End cap catalog number	Catalog number
S200 & S200 P	63	38	1	1044	-	PS1/38H
	80	38	1	1044	-	PS1/38/16H

2 Phase with 1 auxiliary

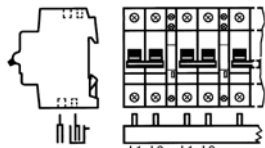

2 Phase + Aux

For use on:	Amp rating	Number of poles	Phases	Busbar length (mm)	End cap catalog number	Catalog number
S200 & S200 P	80	48	2	1065	PS-ENDSP	PS2/48/16SP

3 Phase with 1 auxiliary

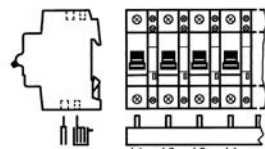

3 Phase + Aux

For use on:	Amp rating	Number of poles	Phases	Busbar length (mm)	End cap catalog number	Catalog number
S200 & S200 P	80	39	3	980	PS-ENDSP	PS3/39/16SP

3 Phase + N, for use with 2 pole-MCBs on 3 phase/4W system

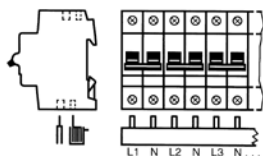

3 Phase + N

For use on:	Amp rating	Number of poles	Phases	Busbar length (mm)	End cap catalog number	Catalog number
S200 & S200 P	80	58	4	1048	PS-END1SP	PS4/58/16NSP

NOTE

ALL BUSBARS MAY BE CENTER FED IN ORDER TO INCREASE AMPACITY UP TO 130 A.

NOTE

BUSBARS MAY BE USED ON LINE OR LOAD SIDE OF MCBS

Accessories

S200 & S200P

UL 1077, CSA 22.2, No. 235



BSK-SP

Busbar tooth covers

Description	Catalog number
Covers five unused poles of busbar	BSK-SP



PS2/6/16 SP

Feeder terminals

Description	Catalog number
Insulated with pin contact, 35mm sq.	AST35/15SP
For side by side mounting; feed on pin of busbar, 50mm sq.	SZ-ESKSP



AST35/15SP



SZ-ESK SP

Technical data

S200, S200P, S200PR & S280UC

UL 1077, CSA 22.2, No. 235

Technical data	S200	S200P	S200PR	S280UC
Specifications:	UL 1077, CSA C 22.2, VDE 0660, 60898, 60947-2		UL1077, CSA 22.2 No. 235, IEC 60947-2	UL1077, CSA 22.2, No. 235
UL File-Number:	E 76126 UL CL	E 76126 UL CL	E 76126 UL CL	-
No. of poles:	1, 2, 3 & 4	1, 2, 3 & 4	1, 2, 3 & 4	1, 2, 3
Tripping characteristics:	B, C, D, K & Z	B, C, D, K & Z	K	K, Z
Rated current:	0.5-63 A	0.2-63 A	0.2-63 A	0.2-63 A
Rated voltage:	Multi pole, 480Y/277 VAC		1 pole, 277 VAC, Multi pole, 480Y/277 VAC	1 pole, 250 VDC, 230 VAC, Multipole, 500 VDC, 480 VAC
Short circuit capacity:	S200 6kA; S200P 10 kA		10 kA	4.5 kA (10 kA, 60 VD 1P, 125 VDC, 2P)
Frequency:	50/60 Hz		50/60 Hz	50/60 Hz
Degree of protection:	IP 20		IP 20, IP40 in enclosure w/cover	IP 20
Mounting position:	Vertical, horizontal		Any	Any
Fixing:	35mm DIN rail			
Clamps only for Cu:	18-4 AWG			
Service life, mech. and at rated load:	20,000 operations		6000 ops (AC), 1 cycle (1s -ON, 9s -OFF)	6000 ops (AC/DC), 1 cycle (1s -ON, 9s -OFF)
Tightening torque:	25 in. lbs (2.8 Nm)			17.5 in. lbs (2.5 Nm)
Ambient temperature:	-25°C ... -13°F / 70°C ... 158°F		-25°C ... +55°C	-25°C ... +55°C
Shock resistance:	30 g at least 3 impacts, shock duration of 11 ms		25g, 2 shocks, 13ms	30g, 3 shocks, 11ms

Auxiliary contact S2C-H6R and Signal contact S2C-S6R for S200, S200P & S200PR

Rated current:	10
Rated voltage AC / DC:	24
Contact:	1 pole, single throw
Connection capacity mm ²	18 - 14 AWG (0.75...2.5)
Tightening torque:	11 in. lbs (1.2 Nm)
Shock resistance acc. to DIN IEC 68-2-6:	5 g, 20 frequency cycles 5...150...5 Hz at 24 VAC/DC, 5 mA auto-reclosing < 10 ms
Mechanical service life:	10,000 operations

Shunt trip

		S2C-A1	S2C-A2
Rated voltage	AC	12 ... 60 V	110 ... 415 V
	DC	12 ... 60 V	110 ... 250 V
Max. release duration		< 10 ms	< 10 ms
Min. release voltage	AC	7 V	55 V
	DC	10 V	80 V
Consumption on release	AD	40 ... 200 VA	55 ... 210 VA
	DC	40 ... 200 VA	55 ... 110 VA
Coil resistance		3.7 Ω	225 Ω
Terminals		18...6/0.75 - 16 AWG/mm ²	18...6/0.75 - 16 AWG/mm ²
Tightening torque		18/2 in.lbs/Nm	18/2 in.lbs/Nm

Undervoltage release

		S2C-UA 12 DC	S2C-UA 24 AC	S2C-UA 24 DC	S2C-UA 48 AC	S2C-UA 48 DC	S2C-UA 110 AC	S2C-UA 110 DC	S2C-UA 230 AC	S2C-UA 230 DC	S2C-UA 400 AC
Standards		IEC/EN 60947-1									
Rated voltage	AC		24 V		48 V		110 V		230 V		400 V
	DC	12 V		24 V		48 V		110 V		230 V	
Frequency		50 ... 60 Hz									
Release trip		0.35 UnOVO 0.7 Un V									
Terminals		2 x 16/2 x 1.5 AWG/mm ²									
Consumption		0.2 VA	3.6 VA	2 VA	3.6 VA	2.1 VA	3.5 VA	2.2 VA	3.7 VA	2.3 VA	2.4 VA
Resistance to corrosion		constant atmosphere: 23/83 - 40/93 - 55/20; variable atmosphere: 25/95 - 40/93 °C/RH									
Protection degree		IPXXB/IP2X									
Tightening torque		3.5/0.4 in.lbs/Nm									

Technical data

S200, S200P & S200PR

UL 1077, CSA 22.2, No. 235

Miniature
circuit breakers
S200

Internal resistance and power loss

Internal resistance per pole in mΩ, power loss per pole in W

Type	Rated current A	Device series B, C, D [Ⓞ]		Device series K		Device series Z	
		mΩ	W	mΩ	W	mΩ	W
S200 & S200P	0.5	5500	1.4	6340	1.6	10100	2.5
	1	1440	1.4	1550	1.6	2270	2.3
	1.6	630	1.6	695	1.8	1100	2.8
	2	460	1.8	460	1.9	619	2.5
	3	150	1.3	165	1.5	202	1.8
	4	110	1.8	120	2.0	149	2.4
	6	55	2.0	52	1.9	104	3.7
	8	15	1.0	38	2.5	53.9	3.45
	10	13.3	1.3	12.6	1.26	17.5	1.7
	13	13.3	2.3	12.6	1.26	-	-
	16	7.0	1.8	7.7	2.0	10.9	2.8
	20	6.25	2.5	6.7	2.7	6.0	2.4
	25	5.0	3.2	4.6	2.9	4.1	2.6
	32	3.6	3.7	3.5	3.6	2.8	2.9
	40	3.0	4.8	2.8	4.5	2.5	4.1
	50	1.3	3.25	1.25	2.9	1.8	4.4
	63	1.2	4.8	0.7	5.2	1.3	5.2

Ⓞ Current intensities 0.5 - 4 apply exclusively to C-type trip characteristics

S200PR

Rated current A	Internal resistance per pole ⁴⁾ mΩ	Power loss per pole ⁴⁾ W
0.2	25300	1.01
0.3	13700	1.23
0.5	4740	1.19
0.75	2067	1.16
1	1270	1.27
1.5	610	1.56
2	442	1.77
3	140	1.26
4	109	1.75
5	50	1.26
6	54	1.94
8	22	1.41
10	18.2	1.82
13	14.8	2.50
15	8.1	1.83
16	11.1	2.83
20	8.5	3.40
25	5.5	3.43
30	3.8	3.39
32	4.6	4.70
35	3.9	4.76
40	2.8	4.40
50	1.7	4.25
60	1.7	6.18
63	1.9	7.56

Temperature derating

Max operating current depending on the ambient temperature of a circuit breaker characteristics type B, C and D

B, C, D, K, & Z	Ambient Temperatures T (C°/F°)											
	-40/-40	-30/-22	-20/-4	-10/14	0/32	10/50	20/68	30/86	40/104	50/122	60/140	70/158
Amps	0.67	0.65	0.62	0.60	0.58	0.55	0.53	0.50	0.47	0.44	0.41	0.37
	1.33	1.29	1.25	1.20	1.15	1.11	1.05	1.00	0.94	0.88	0.82	0.75
	2.13	2.07	2.00	1.92	1.85	1.77	1.69	1.60	1.51	1.41	1.31	1.19
	2.67	2.58	2.49	2.40	2.31	2.21	2.11	2.00	1.89	1.76	1.63	1.49
	4.0	3.9	3.7	3.6	3.5	3.3	3.2	3.0	2.8	2.6	2.4	2.2
	5.3	5.2	5.0	4.8	4.6	4.4	4.2	4.0	3.8	3.5	3.3	3.0
	8.0	7.7	7.5	7.2	6.9	6.6	6.3	6.0	5.7	5.3	4.9	4.5
	10.7	10.3	10.0	9.6	9.2	8.8	8.4	8.0	7.5	7.1	6.5	6.0
	13.3	12.9	12.5	12.0	11.5	11.1	10.5	10.0	9.4	8.8	8.2	7.5
	17.3	16.8	16.2	15.6	15.0	14.4	13.7	13.0	12.3	11.5	10.6	9.7
	21.3	20.7	20.0	19.2	18.5	17.7	16.9	16.0	15.1	14.1	13.1	11.9
	26.7	25.8	24.9	24.0	23.1	22.1	21.1	20.0	18.9	17.6	16.3	14.9
	33.3	32.3	31.2	30.0	28.9	27.6	26.4	25.0	23.6	22.0	20.4	18.6
	42.7	41.3	39.9	38.5	37.0	35.4	33.7	32.0	30.2	28.2	26.1	23.9
	53.3	51.6	49.9	48.1	46.2	44.2	42.2	40.0	37.7	35.3	32.7	29.8
	66.7	64.5	62.4	60.1	57.7	55.3	52.7	50.0	47.1	44.1	40.8	37.3
	84.0	81.3	78.6	75.7	72.7	69.6	66.4	63.0	59.4	55.6	51.4	47.0
	112.6	107.2	102.1	97.2	92.6	88.2	84.0	80.0	76.0	72.2	68.6	65.2
140.7	134.0	127.6	121.6	115.8	110.3	105.0	100.0	95.0	90.3	85.7	81.5	
175.9	167.5	159.5	151.9	144.7	137.8	131.3	125.0	118.8	112.8	107.2	101.8	

Tripping characteristic B

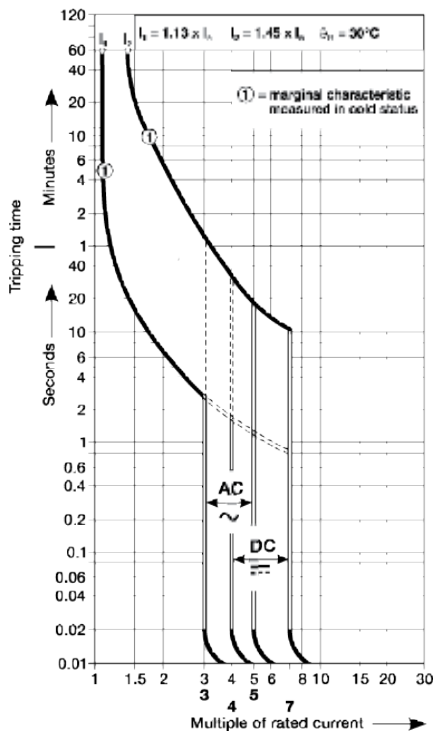

Tripping characteristic C

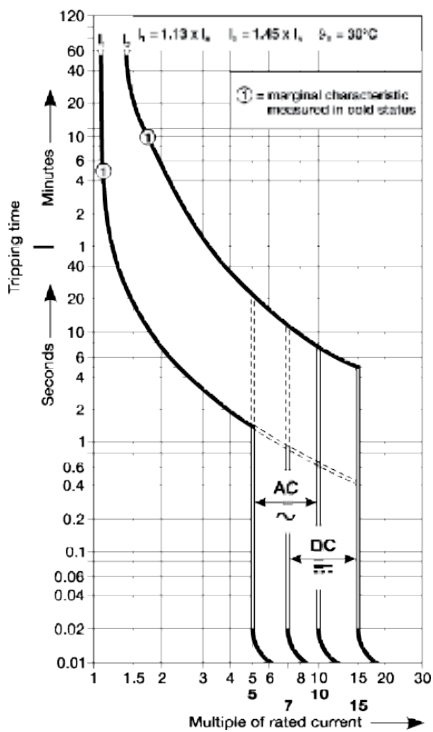

Tripping characteristic D

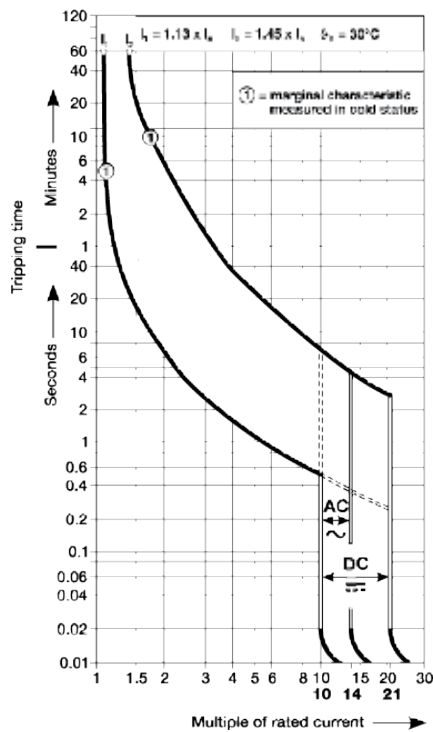

Tripping characteristic K

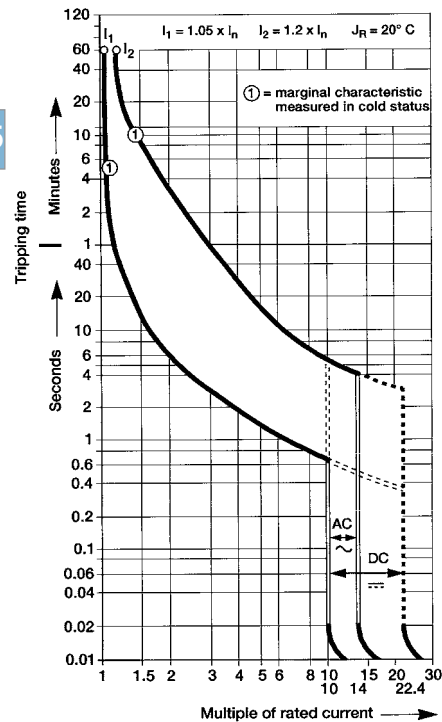

Tripping characteristic Z

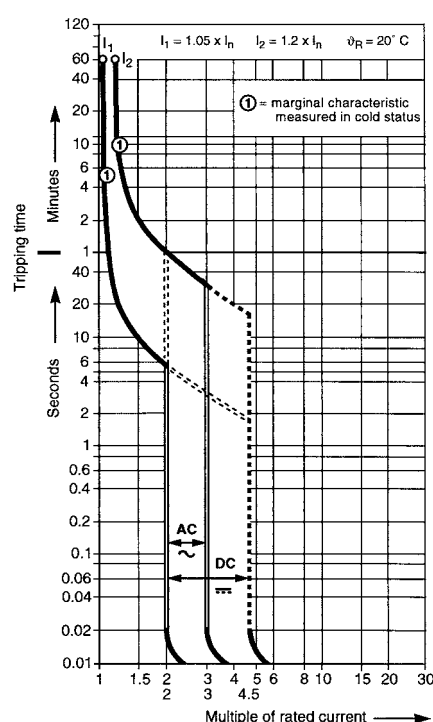

Approximate dimensions S200, S200P, S200PR UL 1077, CSA 22.2, No. 235

S200, S200P

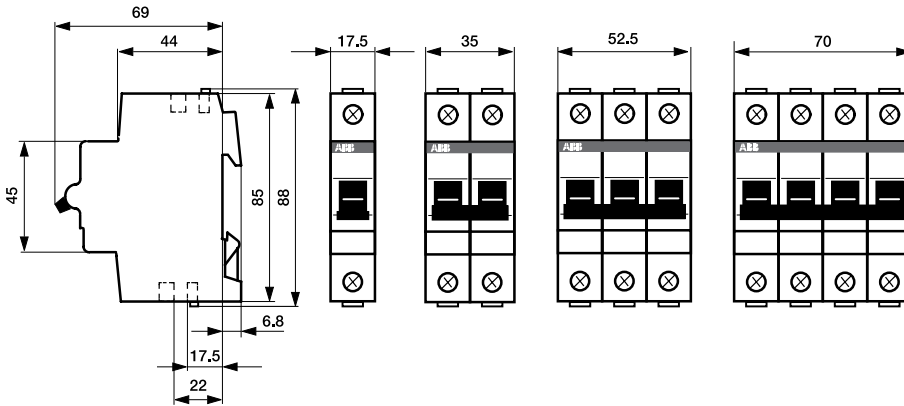

S200PR

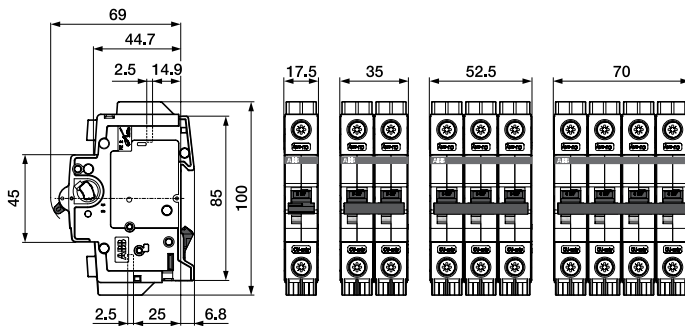

SU200PR Instructions for use

Ring Tongue Details

 Only LISTED or ring cable lugs	Insulated only 	A	B	C
	Rated voltage 480Y/277 V AC	max. 11.0 mm (0.43")	max. 12.2 mm (0.48")	Suitable for M5 (0.20")
Rated voltage 240/240 V AC	Insulated only 	A	B	C
	max. 14.0 mm (0.55")	max. 12.2 mm (0.48")	Suitable for M5 (0.20")	

CU only
 60/75°C
 (140/167°F)

max. 2.0 mm
 (0.08")

PZ 2 Torque: 2.8 Nm (25lb-in)

Ring Tongue Terminal, Special purpose - Not for general use

Installation Instructions

Please insert or withdraw the cable lug only when the screw is completely open.

Please make sure that the terminal screw penetrates the ring lug hole properly and completely during tightening.

Please ensure that the screw is securely tightened before applying any mechanical force on the cable / cable lug.

$< 2.8 \text{ Nm}$
 2.8 Nm

Do not apply abnormal downward pressure on the screw during tightening or loosening of the screw.

F = max. 30 N
 F = Maximum to operate

Please follow the Ring Tongue Details on the rear of this sheet.

Approximate dimensions
S280UC, S2C-H6R, S2C-A...U
UL 1077, CSA 22.2, No. 235

S280UC

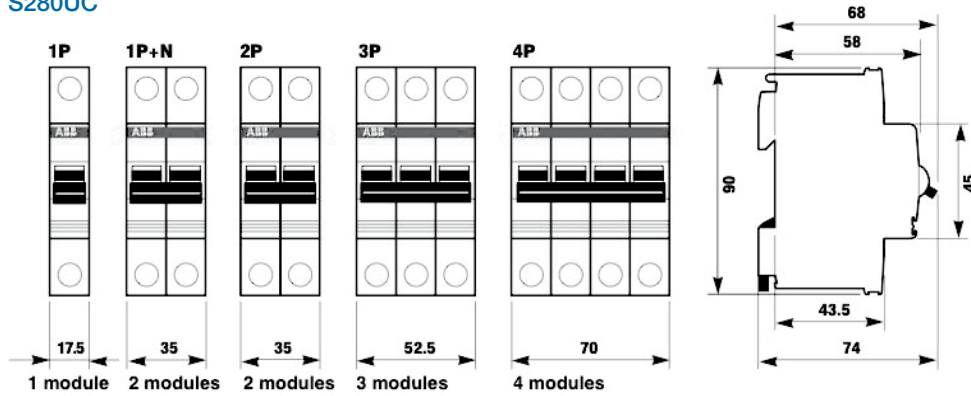

S2C-H6R, S2C-A... S2C

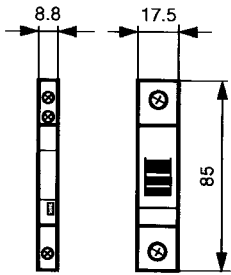

Addition of S2C-A...U

