

SPECIFICATIONS

[1. General Specifications]

Model	SZW-302
Compatible models	CLA□-02□N-□
Mounting Location	Indoor
Mass (Tolerance ±10%)	0.016kg (0.008kg×2)
Quantity	2
Remarks	Do not use in places subject to vibration. No restricted substances exceeding the thresholds of the RoHS Directive are contained.

[2. Outer Dimension]

(Unit : mm)

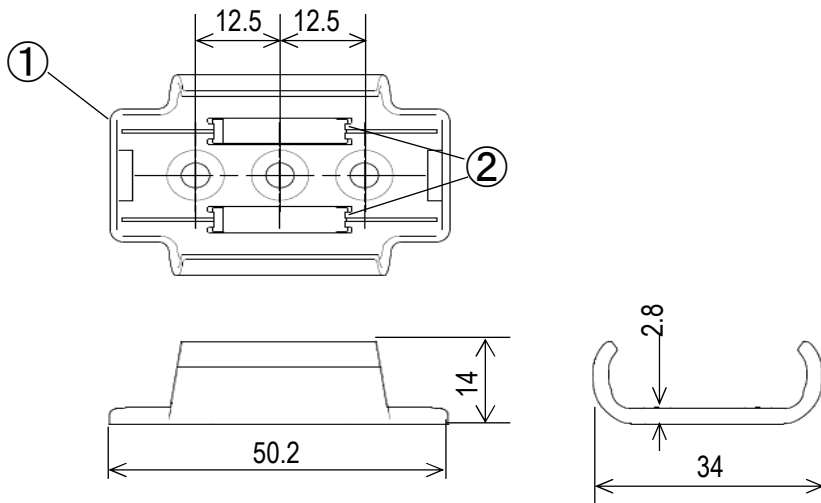

No.	Name	Material	Quantity
1	Bracket	PC	2
2	Magnet	NdFeB	

[3. Mounting Dimensional Drawing]

(Unit : mm)

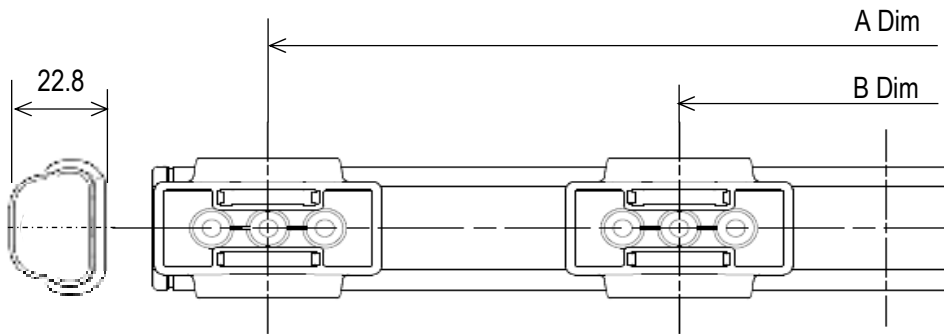

Model	A Dim	B Dim	Number of Brackets used
	Mounting Pitch		
CLA1-02□N-C	74	-	2
CLA2-02□N-C	174	-	
CLA3-02□N-□	274	-	
CLA6-02□N-□	574	-	
CLA9-02□N-C	874	290	4