



Specification of Control Board
(VGA, DVI & Audio supportable)

Model Name : Galaxy 4

Part No. : HERO4-AD-AA104XD12

September 2010

“various LCD panels supportable by one firmware”

Revision History of Galaxy versions

Rev. No.	Rev. date	Revision Details
1.0	Nov.. 2008	<p>Initial Version issued Changed from galaxy1 to Galaxy3 ;</p> <ul style="list-style-type: none"> - RS232 addition (one chip and connector addition on the PCB) – option - Component Video addition (wire type connector addition on the PCB) ; the additional daughter board (YPbPr jack connector / RCA type) requested if customer needs to display the component video. - Scaler Chipset changed from “RTD2533V” to “RTD2533VH” version - MCU changed from Winbond model with cradle type holder on the PCB to SMD type Realtek model (RTD2120L) - Panel selector switch (Dip Switch for LCD model change) ; support for various model of LCD panel by one firmware
2.0	Feb. 2009	Mass Production version
3.0	Nov. 2009	<ul style="list-style-type: none"> - PCB Color change from Green to Dark Blue - Pin map position of 12V DC (4pin wire connection) Connector ; change from GND/GND/12V/12V to 12V/12V/GND/GND (just reverse turns of pin position)
4.0	Sept. 2010	<ul style="list-style-type: none"> - PCB Dimension change ; from 110 x 120 x 14 mm to 120 x 100 x 14 mm The reason why – the vertical size reduction from 120 mm to 100 mm, ➔ in order to meet the vertical size of small size TFT panels such as 7”, 6.5”, etc. - Pin map position, Type of every connectors, OSD Menu design and logic are exactly same as the version 3 (Galaxy 3). - An EPROM for EDID data is added for Analog RGB support. In case of Galaxy 3 version includes the DDC data inside of firmware. However this version 4 (Galaxy 4) has external EPROM. - Backlight control range change The Galaxy3 can support this backlight dimming from “0”V to “3.3”V only. But the version 4 (Galaxy 4) can extend up to “5” V, so it can support more larger range of dimming. - Changing the supportable numbers of TFT LCD panel by one firmware Galaxy3 can support just 32 kinds of panel models by one firmware, but the version 4 (Galaxy4) can support through the extended Selector switch. - Add the circuit for CDS (CaDmium Sulfide) sensor on the PCB

--	--	--

CONTENTS

1. Spec summary	4
2. Electrical Parameters	4
3. Block Diagram	5
4. Pictures	6
5. Dimension	7
6. Connectors and Pin information	8 ~ 10
7. Setup for Operation (OSD)	11
8. Applicable Graphic Mode	12
10. Appendix (Optional Item)	13~

The information presented in this document may form a part of quotation or contract under the agreement of both parties. Otherwise, this datasheet is subject to change without notice.

1. Spec Summary

- Golden coated PCB and RoHS compliant product
- Analog RGB (VGA input) and DVI input supportable
- Full CRT multi-sync monitor compatibility :
 . Multi-sync capability up to WSXGA resolution @ 75Hz, compatible standard
 . DOS, VGA, SVGA, XGA, WXGA, UXGA and WUXGA VESA timing
 . Expand DOS, VGA and SVGA to full screen display
 . True color(16.7 M) data processing and display driving
- Single control operated Embedded On-Screen-Display(hereafter "OSD")
 . user interface, OSD Window support bordering/shadow etc.
 . Full control of all relevant display and interface parameters via OSD
- Multi language support (5 Languages)
- Embedded dual DDC Support DDC1, DDC2B and DDC/CI
- Compatible with VESA DPMS power saving modes
- Low power consumption: operating 40W(PC Only), power save 3W
- +12V / 3.5A DC Single Power : 42 watts AC/DC power adapter recommended
- Signal Power Level selection by Jumper Switch on the PCB : 3.3V, 5.0V, 12V
- Compact Dimension : 110 x 120 X 14 mm
- Operating temperature : 0 ~ 50°C
- Storage temperature : -20 ~ 70°C
- RS-232 Communication support available
- Various LCD panels supported by one firmware through Panel Selector Switch
 (Max. 128 kinds of LCD panel)

2. Electrical Parameters

Symbol	Description	Min	Typ	Max	Unit
V _{DD}	+12V DC Power supply	10.8	12	13.2	V
V _{i(RGB)}	Video input signal(w.r.t. GND)	0.5	0.7	1	V _{pp}
f _S	Video sample rate			70	MHz
f _{HS}	Horizontal sync frequency	30		60	KHz
f _{VS}	Vertical sync frequency	56		75	Hz
F _{SIH}	Sync input high level	3.3			V
V _{SIL}	Sync input low level			0.8	VDC
I _{DD1}	Supply current +12V (w/o LCD & inverter)				A
I _{DD2}	(with LCD & inverter)				A
I _{DDPS1}	Supply current (w/o LCD & inverter, power save)				A
I _{DDPS2}	(with LCD & inverter, power save)				A

3. Block Diagram

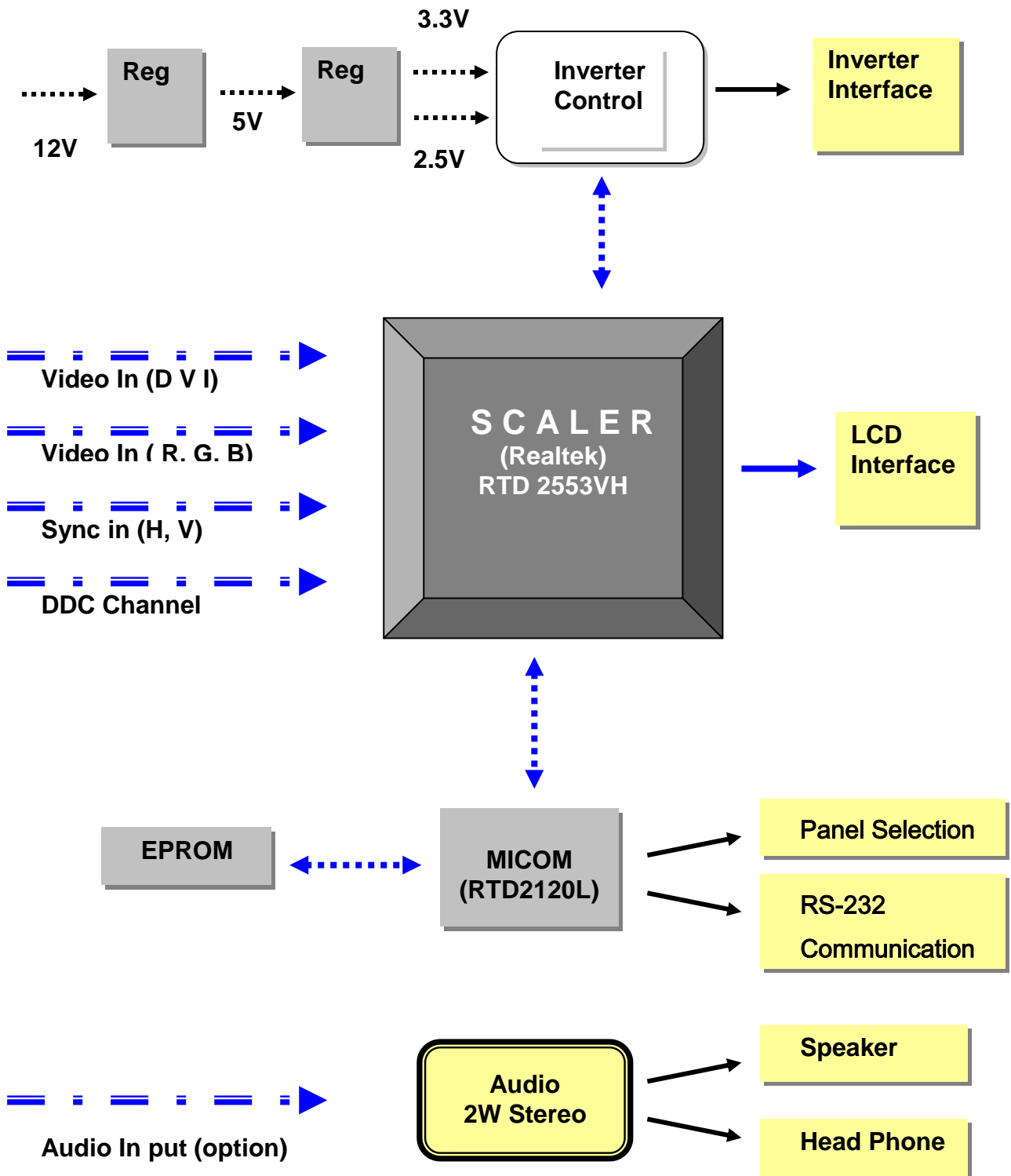

Data Sheet

4. Pictures

4.1 Main Board and OSD (Front View)

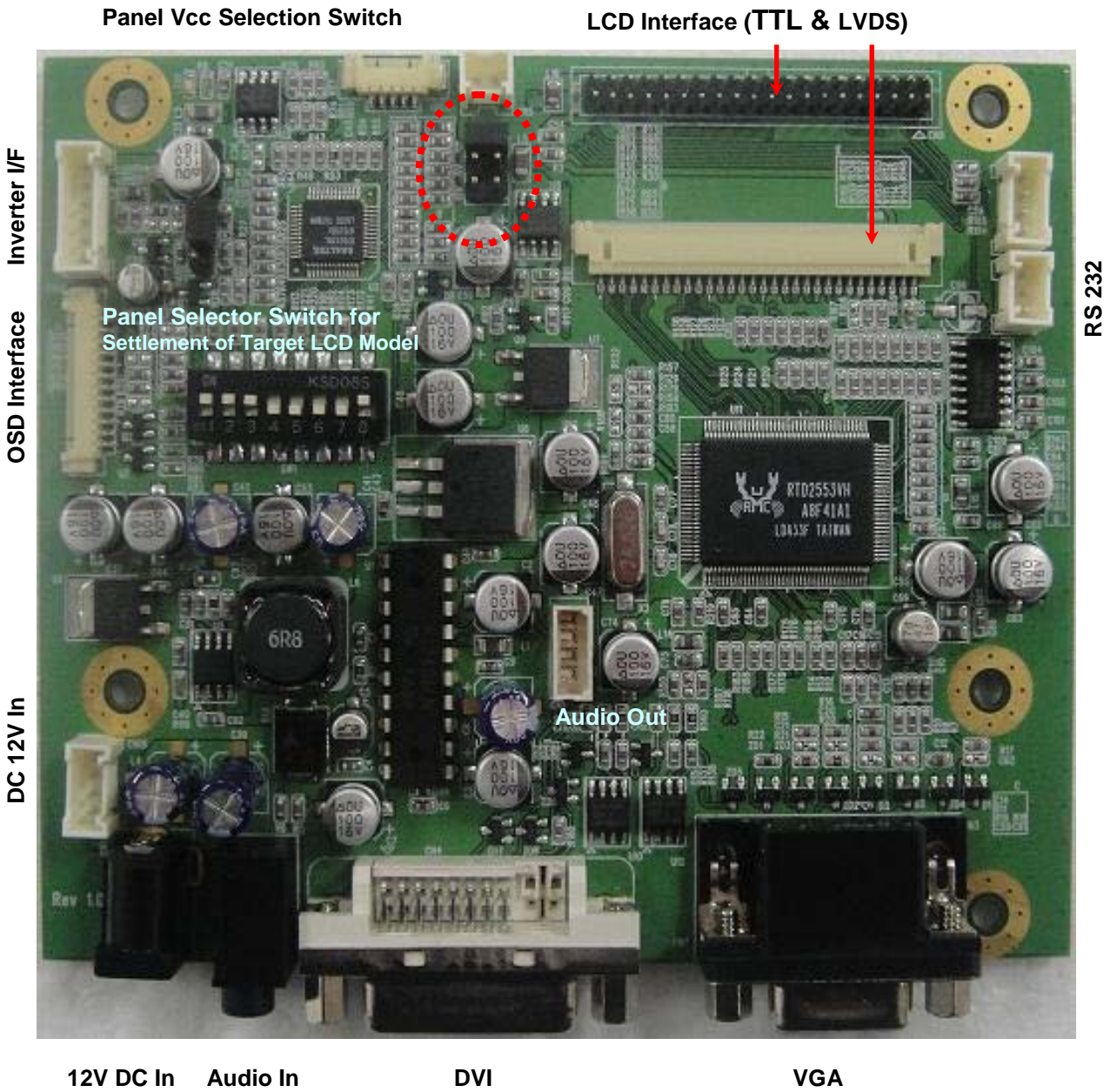

4.2 OSD Board

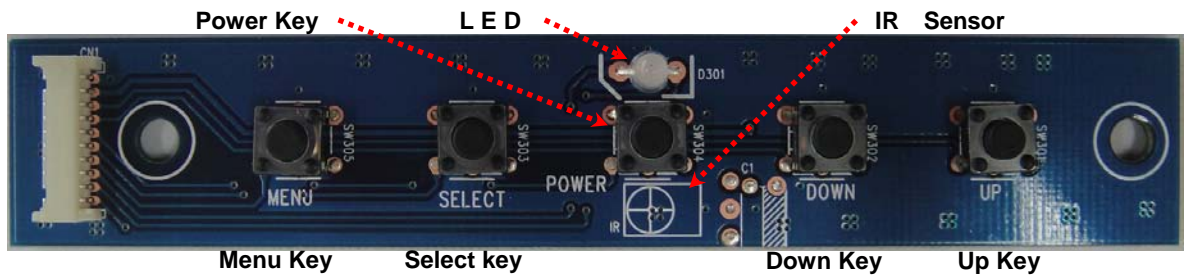

5. Dimension

5.1 Main Board (120 x 100 x 14 mm)

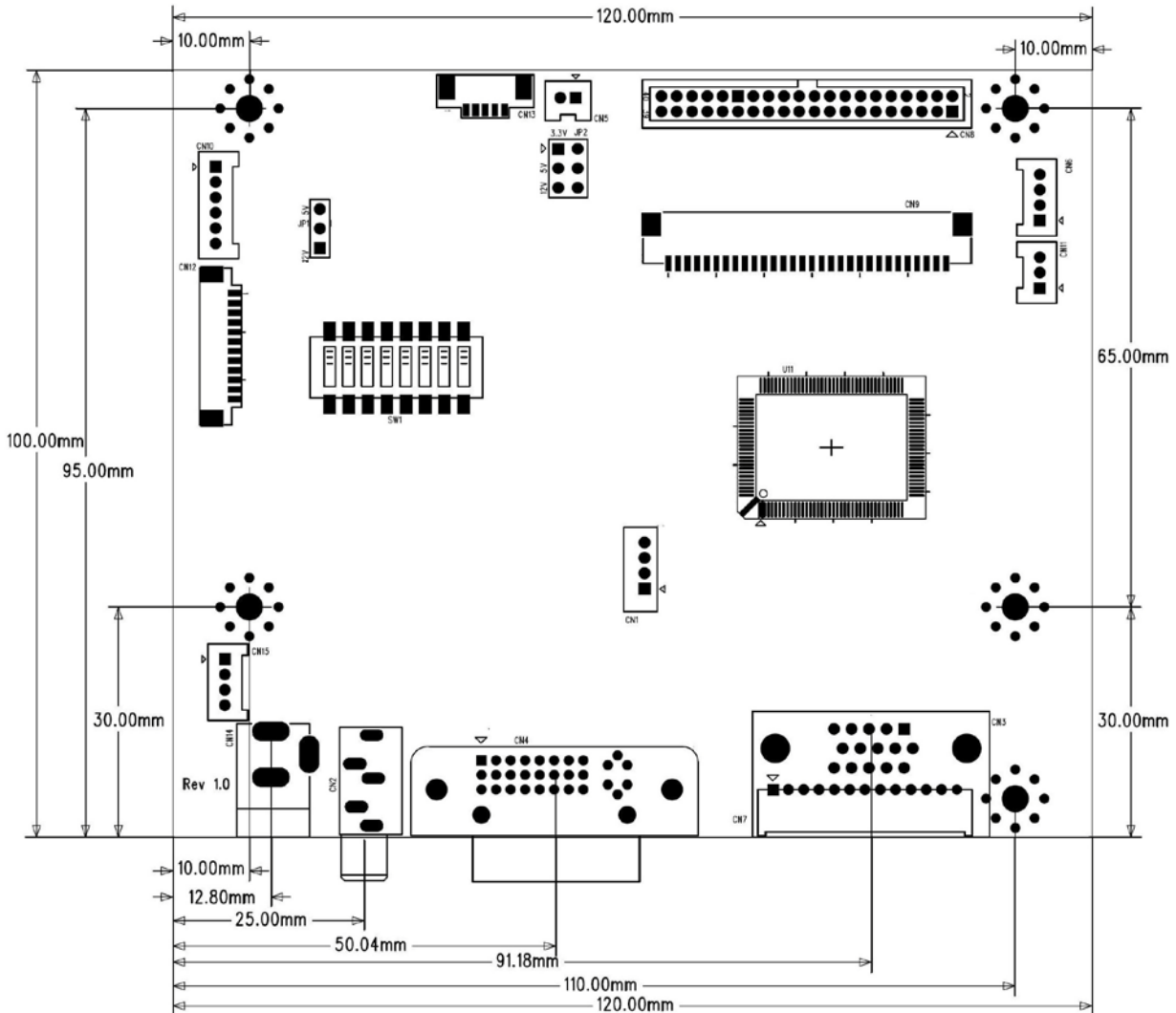

5.2 OSD Board (108.90 x 19.50 mm)

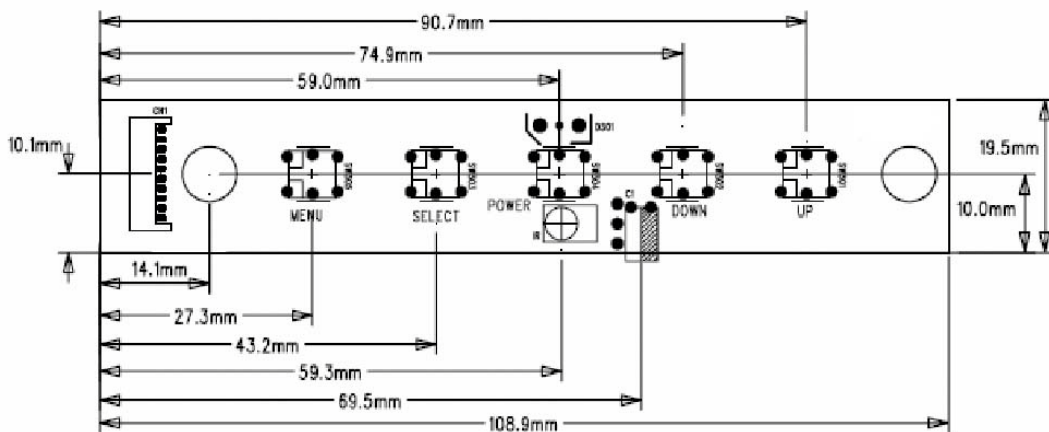

6. Connectors and Pin Information

6.1 Connectors Summary

Service	Maker	Part number	Description	Mating Housing
LCD I/F (LVDS)	Yeon-Ho	12507WR-30P	1.25mm, 30p SMD	Yeon-Ho / 12507HS-30
LCD I/F (TTL)	Molex	87331-20,Head	2mm, 2Row20p, S/T	
VGA IN			2mm,3row 15p R/A	Standard VGA cable(Male)
	Yeon-Ho	SMW200-13	2.0mm, 13P,DIP	Yeon-Ho / SMH200-13
DVI IN			2mm, 25 R/A	Standard DVI cable(Male)
Audio In (Jack Type)	Samsung	ST-323--01	01p R/A	
Speaker Out	Molex	53014-0410	2mm,04p, S/T	0510040400
DC 12V IN		PD527A-1111	2.5 pie, 3 Pin, Jack	Standard DC Adapter
	Yeon-Ho	SMW200-04	2.0 mm, 4 Pin	Yeon-Ho / SMH200-04
DC 5V OUT	Yeon-Ho	SMW200-02	2.0 mm, 2 Pin	Yeon-Ho / SMH200-02
OSD I/F	Yeon-Ho	12505WR-12	1.25mm, 12p SMD	Yeon-Ho / 12507HS-12
Inverter I/F	Yeon-Ho	SMW200-06	2.0mm, 6P,DIP	Yeon-Ho / SMH200-06
RS-232 (*)	Yeon-Ho	SMW200-03	2.0mm, 3P,DIP	Yeon-Ho / SMH200-03
RS-232 (**)	Yeon-Ho	SMW200-04	2.0 mm, 4 Pin	Yeon-Ho / SMH200-04
CDS in	Yeon-Ho	12505WR-05	1.25mm, 5p SMD	Yeon-Ho /12507HS-05

Note :

RS232 (*) : no need the related circuit and components additionally, but requested just 9 pin D-Sub with wire connection

RS232 (**) : requested the related circuit, components and 9 pin D-Sub connection additionally

6.2 Pin Information Detail

6.2.1 LCD I/F - LVDS(CN9)

Pin No.	Function	Pin No	Function	Pin No.	Function
1	PANEL_VCC	11	TXEC-	21	TXO3-
2	PANEL_VCC	12	TXE2+	22	TXOC+
3	PANEL_VCC	13	TXE2-	23	TXOC-
4	FLIP	14	GND	24	GND
5	MIRROR	15	TXE1+	25	TXO2-
6	OPT	16	TXE1	26	TXO2+
7	GND	17	GND	27	TXO1-
8	TXE3+	18	TXE0+	28	TXO1+
9	TXE3-	19	TXE0-	29	TXO0-
10	TXEC+	20	TXO3+	30	TXO0+

6.2.2 LCD I/F – TTL Pin Header (CN8)

Pin No.	Function	Pin No.	Function	Pin No.	Function	Pin No.	Function
1	MIRROR	11	BO5	21	GO5	31	RO5
2	DCLKO	12	BO4	22	GO4	32	RO4
3	FLIP	13	GND	23	GND	33	GND
4	DE	14	BO3	24	GO3	34	RO3
5	GND	15	BO2	25	GO2	35	RO2
6	VSO	16	BO1	26	GO1	36	RO1
7	GND	17	BO0	27	GO0	37	RO0
8	HSO	18	GND	28	GND	38	PANEL_VCC
9	BO7	19	GO7	29	RO7	39	PANEL_VCC
10	BO6	20	GO6	30	RO6	40	5V (option)

6.2.3 VGA IN (CN3)

Pin No.	Function	Pin No.	Function	Pin No.	Function
1	Red	6	GND	11	GND
2	Green	7	GND	12	DDC-SDA
3	Blue	8	GND	13	H Sync
4	GND	9	+5V(Optional)	14	V Sync
5	GND	10	CHECK SIGNAL	15	DDC-SCL

6.2.4 VGA IN (CN7)

Pin No.	Function	Pin No.	Function	Pin No.	Function
1	H Sync	6	GND	11	DDC-SCL
2	GND	7	Green	12	DDC-SDA
3	V Sync	8	GND	13	CHECK SIGNAL
4	GND	9	Red		
5	Blue	10	GND		

6.2.5 DVI IN (CN4)

Pin No.	Function	Pin No.	Function	Pin No.	Function
1	Data2-	9	Data1-	17	Data0-
2	Data2+	10	Data1+	18	Data0+
3	Data2/4 Shield	11	Data1/3 Shield	19	Data0/5 Shield
4	Data4-	12	Data3-	20	Data5-
5	Data4+	13	Data3+	21	Data5+
6	DDC Clock	14	+5V Power	22	Clock Shield
7	DDC data	15	GND(for +5V)	23	Clock+
8	No connect	16	Hot Plug Detect	24	Clock-

6.2.6 AUDIO IN (CN2)

Pin No.	Function	Pin No.	Function	Pin No.	Function
1	GND	3	GND	5	GND

Data Sheet

2	AUDIO L In	4	AUDIO R In		
---	------------	---	------------	--	--

6.2.7 SPEAKER OUT (CN1)

Pin No.	Function	Pin No.	Function
1	Speaker Out (Right)	3	Speaker Out (Left)
2	Ground	4	Ground

6.2.8 DC 12V IN -JACK (CN14)

Pin No.	Function	Pin No.	Function	Pin No.	Function
1	DC 12V	2	Ground	3	Ground

6.2.9 DC 12V IN (CN15)

Pin No.	Function	Pin No.	Function
1	Ground	3	DC 12V
2	Ground	4	DC 12V

6.2.10 DC 5V OUT (CN5)

Pin No.	Function	Pin No.	Function
1	Ground	2	DC 5V

6.2.11 OSD I/F (CN12)

Pin No.	Function	Pin No.	Function	Pin No.	Function
1	MENU	5	UP	9	LED2
2	SELECT	6	EXTRA1	10	GND
3	DOWN	7	EXTRA2	11	VDD
4	POWER	8	LED1	12	IR In

6.2.12 Inverter IN (CN10)

Pin No.	Function	Pin No.	Function	Pin No.	Function
1	12V	3	Ground	5	BL ON
2	5V(Optional)	4	Ground	6	BKLT ADJ

6.2.13 RS232 I/F (CN11)

Pin No.	Function	Pin No.	Function	Pin No.	Function
1	TX	2	RX	3	GND

6.2.14 CDS IN (CN13)

Pin No.	Function	Pin No.	Function	Pin No.	Function
1	Ground	3	3.3V	5	Ground
2	CDS IN	4	N.C		

7. Setup for Operation

The OSD (On Screen Display) provides certain functions to have clear image and others, which consists of 5 buttons as a standard. The control functions defined as follows.

7.1 Functions on the OSD menu

Level - 1	Level - 2	Level - 3	Description
Color	Contrast	Total: 100 steps	Adjusts Contrast of image
	Brightness	Total: 100 steps	Adjusts brightness of image
	Color Adjust	Red /Green/ Blue	Adjusts Color of image
	Color Temp	9300/6500/5800/USER	Adjusts color temperature of image
Image setting	Clock	Total: 100 steps	Adjust the clock pulse of image
	Phase	Total: 63 steps	Adjust the focus of image
	Gamma	0/1/2/3	Adjusts Gamma of image
	Sharpness	0/1/2/3/4	Adjusts sharpness of image
Position	H. Position	Total: 100 steps	Horizontal Screen Position change
	V. Position	Total: 100 steps	Vertical Screen Position change
	Mirror	ON/OFF	Mirror Selection of image (supportable by built-in board of LCD panel)
	Flip	ON/OFF	Flip Selection of image (supportable by built-in board of LCD panel)
OSD Menu	OSD H. Position	Total: 100 steps	Horizontal Screen Position change for OSD Menu
	OSD V. Position	Total: 100 steps	Vertical Screen Position change for OSD Menu
	OSD Timer	Total: 60 steps	Adjust the display time setting of OSD Menu
Language	English		Language Selection of OSD Menu display
	Français	French	
	Deutsch	German	
	Español	Spanish	
	繁體中文	Chinese – 1	
	簡體中文	Chinese – 2	
	日本語	Japanese	
Korean(한국어)	Korean		
Misc	Signal Source	RGB / DVI	Selects input source
	Volume	Total: 100 steps	Adjusts sound volume
	Mute	ON / OFF	Selects sound On/OFF
	Back Light	Total: 100 steps	Adjusts Back Light of image (Backlight Control)
	Reset		Initializing that memory in store of the user mode
Exit			

Note : The above steps can be specified for example 250 steps of Brightness, Contrast, Backlight level by an optional order

7.2 Definition of Hotkey Functions

OSD Key	Function	OSD Key	Function	OSD Key	Function
Down	Auto Adjust	Up	Auto Color Calibration	Power + Down	Factory Reset

8. Applicable Graphic Mode

The microprocessor measures the H-sync, V-sync and V-sync/H-sync polarity for RGB inputs, and uses this timing information to control all of the display operation to get the proper image on a screen.

This board can detect all VESA standard and MAC Graphic modes shown on the table below and provide more clear and stable image on a screen.

RGB & DVI Input format

Mode \ Spec.	Pixel Freq.		Horizontal Timing				Vertical Timing			
			Sync Polar	Freq.	Total	Active	Sync Polar	Freq.	Total	Active
	MHz		KHz	Pixel	Pixel		Hz	Line	Line	
640x350 @70Hz	25.144	VESA	P	31.430	800	640	N	70.000	449	350
720x400 @70Hz	28.287	VESA	N	31.430	900	720	P	70.000	449	400
640x480 @60Hz	25.175	MAC	N	31.469	800	640	N	59.940	525	480
640x480 @60Hz	25.175	VESA	N	31.469	800	640	N	59.940	525	480
640x480 @67Hz	30.240	MAC	N	35.000	864	640	N	66.667	525	480
640x480 @72Hz	31.500	VESA	N	37.861	832	640	N	72.809	520	480
640x480 @75Hz	31.500	VESA	N	37.500	840	640	N	75.000	500	480
832x624 @75Hz	57.284	MAC	N	49.726	1152	832	N	74.551	667	624
800x600 @56Hz	36.000	VESA	P	35.156	1024	800	P	56.250	625	600
800x600 @60Hz	40.000	VESA	P	37.879	1056	800	P	60.317	628	600
800x600 @72Hz	50.000	VESA	P	48.077	1040	800	P	72.188	666	600
800x600 @75Hz	49.500	VESA	P	46.875	1056	800	P	75.000	625	600
1024x768 @60Hz	65.000	VESA	N	48.363	1344	1024	N	60.005	806	768
1024x768 @60Hz	64.000	MAC	N	48.780	1312	1024	N	60.001	813	768
1024x768 @70Hz	75.000	VESA	N	56.476	1328	1024	N	70.070	806	768
1024x768 @75Hz	80.000	MAC	N	60.241	1328	1024	N	74.927	804	768
1024x768 @75Hz	78.750	VESA	P	60.023	1312	1024	P	75.030	800	768
1280x768 @60Hz	79,500	VESA	P	47,780	1664	1280	P	59,870	798	768
1280x1024 @60Hz	108.000	VESA	P	63.981	1688	1280	P	60.020	1066	1024
1280x1024 @75Hz	135.000	VESA	P	79.976	1688	1280	P	75.025	1066	1024
1360X768 @60Hz	85.00	VESA	P	47.712	1792	1360	P	60.015	795	768
1600x1200 @60Hz	160.875	VESA	N	74.479	2160	1600	P	59.967	1242	1200
1680x1050 @60Hz	147.000	VESA	N	65.160	2256	1680	P	59.944	1087	1050
1920x1080 @60Hz	172.750	VESA	N	67.061	2576	1920	P	59.983	1118	1080
1920X1200@60Hz	193.125	VESA	N	74.508	1292	1920	P	59,990	1242	1200

--	--	--	--	--	--	--	--	--	--

9. Appendix - A (Option : Spec. for 24V DC Power Board)

This is an optional daughter board which can support the direct power supply at 24V DC from a main system power to 12V basis AD card or similar devices.

In case of large screen size LCD modules which have 16V ~ 27V DC input for backlight and related power, most of them need to combine this optional daughter board for easy fit up without additional devices.

9.1 Block Diagram

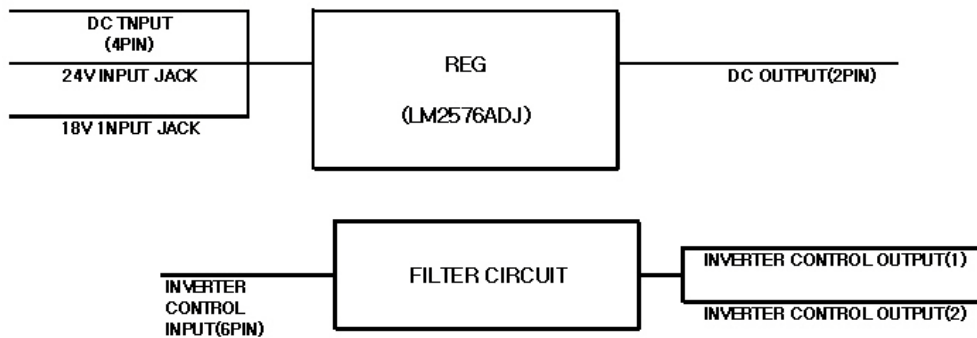

9.2 Dimension and Picture

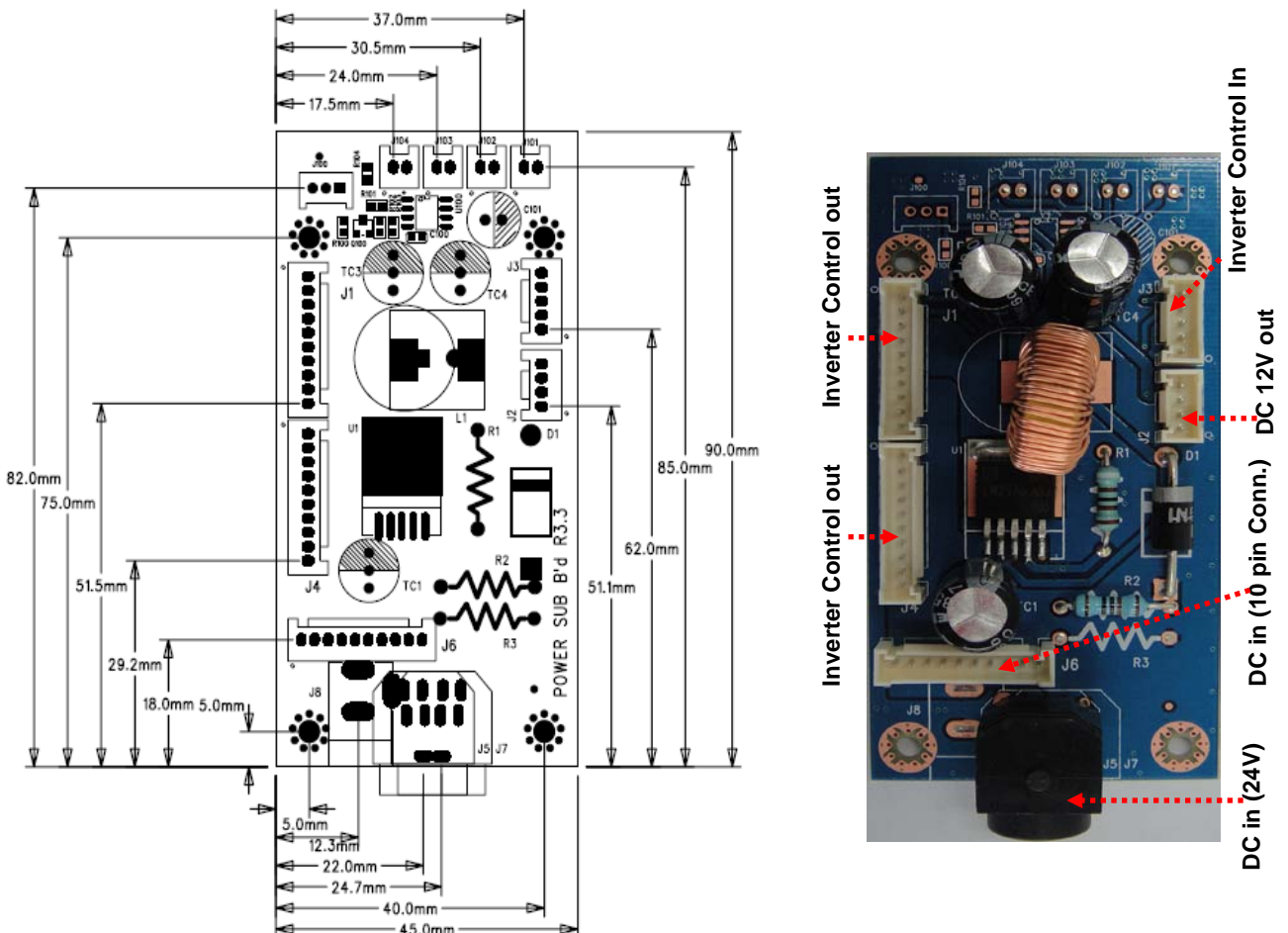

9.3 Pin Information

• **DC in (J5, DJ08-4-P)**

Pin No	Symbol	Pin No	Symbol
1	GND	3	GND
2	24V	4	24V

• **DC in (J6, SMW200-10, Yeon-Ho)**

Pin No	Symbol	Pin No	Symbol
1 ~ 5	24V	6 ~ 10	GND

• **Inverter Control output Connector (J1 & J4, SMW200-10, Yeon-Ho)**

Pin No	Symbol	Pin No	Symbol
1	INV ON/OFF	6	GND
2	DIMMING	7	24V
3	GND	8	24V
4	GND	9	24V
5	GND	10	24V

• **Inverter Control Input Connector (J3, SMW200-05, Yeon-Ho)**

Pin No	Symbol	Pin No	Symbol
1	RESERVED	4	DIMMING
2	GND	5	INV ON/OFF
3	GND		

• **DC Output (J2, SMW200-04, Yeon-Ho)**

Pin No	Symbol	Pin No	Symbol
1	GND	3	12V
2	GND	4	12V

9.4 Reference Data

Limiting Value

Symbol	Description	Min	Max	Unit
DC in	Input Voltage Level	16	27	Vdc
DC out	Output Voltage Level	11	13	Vdc
Output Current	Output Current Level		5	Adc

Etc. Data

Parameter	Value	Unit
Dimensions		
Depth	90	mm
Width	45	mm
Height	30	mm
Operating Temperature	-10 ~ 60	°C
Storage Temperature	-20 ~ 80	°C

10. Appendix - B (Option : RS232 control Protocols)

RS-232 Serial control (Baud rate 2400, 8 bits, 1 stop bit and no parity)
Physical connection :

Controller side :
Connector interface : CN 200
Mating connector : SMW200-03, Yeon-Ho

Computer side :
Connector interface : Serial port
Mating connector : DB9 Female

PIN#	Description
1	RS-232 Rx Data
2	RS-232 Tx Data
3	Ground

PIN#	Description
2	RS-232 Rx Data
3	RS-232 Tx Data
5	Ground

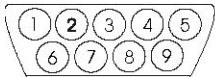

Remark :

(1) : RS-232 connection cable, 600mm P/N 4260902-00 can be ordered separately for connection.

Software connection :

The OSD function can be controlled through sending the RS-232 protocol.

The RS-232 program can be custom-made to fit for application or it can be used the serial control program, like Accessport, Telix or Serial Utility program complying with DigitalView.

10.1. Commands to implement switch mount control buttons

Function	Command	Description	Remark
Menu button	0xf7	Menu button pressed	Button equivalent
Select-down button	0xfa	Select-down button pressed	Button equivalent
Select-up button	0xfb	Select-up button pressed	Button equivalent
Right/+ button	0xfc	Right/+ button pressed	Button equivalent
Left/- button	0xfd	Left/- button pressed	Button equivalent

10.2. Parameter setting - immediate, relative, reset and query

Function	Command	Description	Acknowledge (if enabled)
Volume control -left+right channel	0x80, "a" "A", nn "+" "-" "r" "R" "?"	Set audio (L+R) volume = value/increment/decrement Reset Query	volume Range : "0"0-"1"1"E" Default : "0"1"F"
Volume control -on/off (mute)	0x80, "m" "M", "0" "1" "r" "R" "?"	Disable audio output. Enable audio output. Reset Query	"0" - audio off (muted). "1" - audio on.

Data Sheet

Brightness control	0x81, nn "+" "-" "r" "R" "?"	Set brightness = value/increment/decrement Reset Query	Brightness. Range : "4"0"E"- "B"2 Default : "8"0
Contrast control - all channels	0x82, "a" "A", nn "+" "-" "r" "R" "?"	Set all contrast = value/increment/decrement Reset Query	Contrast Range : "1"0"C"- "E"4 Default : "8"0
Saturation control	0x83, nn "+" "-" "r" "R" "?"	Set saturation = value/increment/decrement Reset Query	PAL/NTSC color (In video mode only) Range : "0"1"- "F"4 Default : "8"0
Hue control	0x84, nn "+" "-" "r" "R" "?"	Set hue = value/increment/decrement Reset Query	NTSC tint (In NTSC mode only) Range : "5"3"- "9"4 Default : "7"9
Phase (tuning) control	0x85, nn "+" "-" "?"	Set dot clock phase = value/increment/decrement Query	Dot clock phase. (In PC mode only)
Image H position	0x86, nnnn "+" "-" "?"	Set img_hpos = value/increment/decrement Query	Image horizontal position. (In PC mode only)
Image V position	0x87, nnnn "+" "-" "?"	Set img_vpos = value/increment/decrement Query	Image vertical position. (In PC mode only)
Sharpness	0x8a, nn "+" "-" "r" "R" "?"	Set sharpness = value/increment/decrement Reset Query	Sharpness. (Video Mode Source only) Range : "F"1"- "0"4 Default : "0"0
Frequency	0x8b, nnnn "+" "-" "?"	Set frequency = Value/increment/decrement Query	Graphic mode H active size (in pixels)
Scaling Mode	0x8c, "0" "1" "2" "3" "9" "A" "B" "C" "D" "r" "R" "?"	Set graphic image scaling mode = value Reset Query	Image expansion on/off. "0" – 1:1 "1" – fill screen "2" – fill to aspect ratio "9" – 4:3 "A" – 16:9 "B" – 16:10 "C" – 2.35:1 "D" – 2:1
Set display orientation	0x8e, n "r" "R" "?"	Set display orientation = value/increment/decrement Reset Query	"0" – normal. "1" – vertical inverse. "2" – horizontal inverse. "3" – inverted.
OSD H position	0x90, nnn "+" "-" "r" "R" "?"	Set osd_hpos = value/increment/decrement Reset Query	OSD horizontal position. Range : "0"0"- "F"4 Default : "8"0
OSD V position	0x91, nnn "+" "-" "r" "R" "?"	Set osd_vpos = value/increment/decrement Reset Query	OSD vertical position. Range : "0"0"- "F"4 Default : "8"0
OSD Transparency	0x92, n "+" "-" "r" "R" "?"	Set OSD transparency = value/increment/decrement Reset Query	OSD transparency. "0" – ON "1" - OFF

Data Sheet

OSD menu timeout	0x93, nn "+" "-" "I" "R" "?"	Select menu timeout = value/increment/decrement Reset Query	OSD menu timeout value. "0"0" – Continuous. value – Round up to nearest available step. if value > max available step, set it to the max available step. Range : "0"5"-3"C" Default : "0"A"
Select OSD language	0x95, n "I" "R" "?"	Select language = English, Chinese,... Reset Query	"0" – English. "8" – Chinese
Input main select	0x98, nn "+" "-" "I" "R" "?"	Select input main = PC or VIDEO or next available Reset Query	Main selected. 0x41, 0x31 : ARGB 0x42, 0x31 : Composite 0x43, 0x31 : S-video 0x44, 0x31 : SD Component 0x45, 0x31 : HDS DI 0x46, 0x31 : DVI 0x47, 0x31 : HD Component 0x42, 0x32 : Composite 2 0x43, 0x32 : S-video 2 0x44, 0x32 : SD Component 2 0x45, 0x32 : HDS DI 2 (Source sequence : S-Video -> SD component -> HD/SD SDI1 -> HD/SD SDI2 -> ARGB -> DVI -> Composite -> Composite 2 -> S-Video)
Auto Source Seek	0x99, "0" "1" "I" "R" "?"	Set Auto source seek = OFF/ON Reset Query	"0" – OFF "1" – ON
Video System (Composite, S-video and Component Only)	0x9b, "0" "1" "2" "3" "I" "R" "S" "s" "?"	Set video system = Auto/NTSC/PAL/SECAM Reset Video State Query Query	Query "0" – Auto. "1" – NTSC_M_358 "2" – PAL_N_443 "3" – SECAM "4" – NTSC_M_443 "5" - PAL_M_358 "6" – NTSC_N_358 "7" – PAL_M_443 "8" – NTSC_N_443 "9" – PAL_N_358 ----- Video State Query "0" – No video. "1" – NTSC "2" – PAL "3" – SECAM
GAMMA value select	0x9d, n "I" "R" "?"	Select GAMMA value = Value Reset Query	GAMMA value: "0" – 1.0, "1" – 1.6 "2" – 2.2 "3" – User Defined

Data Sheet

Auto power off	0x9f, "0" "1" "r" "R" "?"	Set power down option = On/Off Reset Query	"0" – Off. "1" – On.
Hotkey 1	0xa0, "1", n "r" "R" "?"	Set Hotkey 1= Value Reset Query	"1" – volume. "2" – brightness. "3" – contrast. "4" – colour. "5" – input source. "7" – zoom "8" – freeze "9" – PIP "D" – PIP Swap "E" – Aspect "F" – Orientation "G" – Hue "H" – Backlight
Hotkey 2	0xa0, "2", n "r" "R" "?"	Set Hotkey 2 = value Reset Query	"1" – volume. "2" – brightness. "3" – contrast. "4" – colour. "5" – input source. "7" – zoom "8" – freeze "9" – PIP "D" – PIP Swap "E" – Aspect "F" – Orientation "G" – Hue "H" – Backlight
Runtime counter	0xa1, nnnnn "r" "R" "?"	runtime counter value = nnnnn (* 0.5 hour) Reset Query	Runtime = nnnnn.
PIP brightness control	0xa2, nn "+" "-" "r" "R" "?"	Set PIP window brightness = value/increment/decrement Reset Query	PIP window brightness. Range : "4""E"- "B""2" Default : "8""0"
PIP contrast control	0xa3, nn "+" "-" "r" "R" "?"	Set PIP window contrast = value/increment/decrement Reset Query	PIP window contrast. Range : "1""C"- "E""4" Default : "8""0"
PIP H position	0xa4, nnn "+" "-" "r" "R" "?"	Set PIP_hpos = value/increment/decrement Reset Query	PIP window horizontal position. Range : "0""0""0"- "0""6""4" Default : "0""5""5"
PIP V position	0xa5, nnn "+" "-" "r" "R" "?"	Set PIP_vpos = value/increment/decrement Reset Query	PIP window vertical position. Range : "0""0""0"- "0""6""4" Default : "0""1""4"
PIP window size select	0xa6, nn "r" "R" "?"	Select PIP window size = PIP window size value Reset Query	Main selected. "0""0" - PIP off (Default) "0""1" - PIP small "0""2" - PIP medium "0""3" - PIP large "0""4" - PBP

Data Sheet

PIP source select	0xa7, n "r" "R" "?"	Select input main = Video source value Reset Query	Main selected. 0x41, 0x31 : ARGB 0x42, 0x31 : Composite 0x43, 0x31 : S-video 0x44, 0x31 : SD Component 0x45, 0x31 : HDSDI 0x46, 0x31 : DVI 0x47, 0x31 : HD Component 0x42, 0x32 : Composite 2 0x43, 0x32 : S-video 2 0x44, 0x32 : SD Component 2 0x45, 0x32 : HDSDI 2
Zoom level	0xa8, nnnn "+" "-" "r" "R" "?"	Set Zoom level = value/increment/decrement Reset Query	Zoom level. Min : 0x30 0x30 0x30 0x30 (Default) Max : 0x30 0x30 0x41 0x33
Zoom H position	0xa9, nnnn "+" "-" "r" "R" "?"	Set Zoom_hpos = value/increment/decrement Reset Query	Zoom window horizontal position. Default : 0x30 0x30 0x30 0x30 The min and max values will change depends on input resolution.
Zoom V position	0xaa, nnnn "+" "-" "r" "R" "?"	Set Zoom_vpos = value/increment/decrement Reset Query	Zoom window vertical position. Default : 0x30 0x30 0x30 0x30 The min and max values will change depends on input resolution.
Horizontal Size	0xad, nnn "+" "-" "r" "R" "?"	Set horizontal size for Aspect Size = value/increment/decrement Reset Query	Scalar horizontal stretch PAL(576i) / NTSC (480i) : Min : 0x30 0x30 0x30 (Default) Max : 0x30 0x46 0x30
Vertical Size	0xb0, nnn "+" "-" "r" "R" "?"	Set Vertical Size for Aspect Size = value/increment/decrement Reset Query	Scalar vertical stretch. PAL(576i) / NTSC (480i) : Min : 0x30 0x30 0x30 (Default) Max : 0x30 0x46 0x30
Horizontal Pan	0xb1, nnn "+" "-" "r" "R" "?"	Set horizontal pan position for Aspect Size = value/increment/decrement Reset Query	Scalar horizontal pan position PAL(576i) / NTSC (480i) : Assume max H-Size & max V-size : Min : 0x46 0x38 0x38 Max : 0x30 0x37 0x38 Default : 0x30 0x30 0x30 The min and max values will change depends on different value of H-Size, V-Size and input resolution.

Data Sheet

Vertical Pan	0xb2, nnn "+" "-" "I" "R" "?"	Set Vertical pan position for Aspect Size = value/increment/decrement Reset Query	Scalar vertical pan position PAL(576i) / NTSC (480i) : Assume max H-Size & max V-size : Min : 0x46 0x38 0x38 Max : 0x30 0x37 0x38 Default : 0x30 0x30 0x30 The min and max values will change depends on different value of H-Size, V-Size and input resolution.
Colour temperature select	0xb3, n "I" "R" "?"	Select colour temperature = value Reset Query	Main selected. "0" – 9500K. "1" – 8000K. "2" – 6500K. "3" – 5000K "4" - User
Red level for selected colour temperature	0xb4, nn "+" "-" "I" "R" "?"	Set the level of the red channel for the selected colour temp. = value/increment/decrement Reset Query	Red level for selected colour temperature. Range : "9" "C" - "F" "F" Default : "E" "C"
Green level for selected colour temperature	0xb5, nn "+" "-" "I" "R" "?"	Set the level of the green channel for the selected colour temp. = value/increment/decrement Reset Query	Green level for selected colour temperature. Range : "9" "C" - "F" "F" Default : "E" "C"
Blue level for selected colour temperature	0xb6, nn "+" "-" "I" "R" "?"	Set the level of the blue channel for the selected colour temp. = value/increment/decrement Reset Query	Blue level for selected colour temperature. Range : "9" "C" - "F" "F" Default : "E" "C"
Graphic horizontal resolution enquiry	0xb7	Horizontal resolution (in pixels) in 3 digit hex number	"nnn" = horizontal resolution
Graphic vertical resolution enquiry	0xb8	Vertical resolution (in lines) in 3 digit hex number	"nnn" = vertical resolution
Graphic horizontal sync frequency enquiry	0xb9	Horizontal sync frequency (in units of 100Hz) in 3 digit hex number	"nnn" = horizontal frequency
Graphic vertical sync frequency enquiry	0xba	Vertical sync frequency (in units of Hz) in 3 digit hex number and 1 char	"nnnn" = vertical frequency nnn = 3 digit hex c= "i" or "p" interlace or Progressive 0xba added the interlace(i) or Progressive(p) feedback.
OSD status enquiry	0xbb	Status of OSD	"0" – OSD turned off "1" – OSD turned on
OSD turn off	0xbd	Turn off the OSD.	"1" – successful.

Data Sheet

Set gamma data for user defined gamma curve	0xbf, mm, c, "?" 0xbf, "R" "r" 0xbf, mm, c, nn	Query gamma data for color c index mm (c = 0 for color Red, c=1 for color Green, c=2 for color Blue) Set user gamma curve to linear Set gamma data for color c index mm. (If c= 3, then gamma data for red, green & blue will be set at the same time.)	"nn" = gamma data "1" "nn" = gamma data
Backlight control	0xe0, nn "+" "-" "R" "r" "?"	Set Backlight = value/increment/decrement Reset Query	Backlight. Range: D/A : "0"0" ~ "1"6" 100Hz : "0"0" ~ "8"A" 120Hz : "0"0" ~ "7"3" 140Hz : "0"0" ~ "6"3" 160Hz : "0"0" ~ "5"6" 180Hz : "0"0" ~ "4"D" 200Hz : "0"0" ~ "4"5" 220Hz : "0"0" ~ "3"E" 240Hz : "0"0" ~ "3"9" 260Hz : "0"0" ~ "3"5" 280Hz : "0"0" ~ "3"4" 300Hz : "0"0" ~ "2"E" 320Hz : "0"0" ~ "2"B" 340Hz : "0"0" ~ "2"8" 360Hz : "0"0" ~ "2"6" 380Hz : "0"0" ~ "2"4" 400Hz : "0"0" ~ "2"2" 420Hz : "0"0" ~ "2"0" 440Hz : "0"0" ~ "1"F"
Backlight On/Off	0xe1, "0" "1" "R" "r" "?" "S" "s"	Backlight Off / Backlight On /Status	"0" – Backlight Off "1" – Backlight On. "?" – Backlight On/Off Quer "S" "s" – Backlight Status Query
Color Monochrome mode selection (Output Channel Select)	0xe2 "0" "1" "2" "3" "4" "5" "6" "R" "r" "?"	Off/ Blue Only/ Red Only/ Green Only/ Blue Mono/ Red Mono/ Green Mono/	"0" – Off "1" – Blue Only "2" – Red Only "3" – Green Only "4" – Blue Mono "5" – Red Mono "6" – Green Mono
PIP Swap	0xe3	Swap Main and PIP source	"0" - Fail. "1" - Successful.
Backlight D/A / PWM	0xe5 "0" "1" "R" "r" "?"	Set : PWM or D/A Reset Query	"0" – PWM "1" – D/A

Data Sheet

Backlight PWM Frequency	0xe6, nnn "+" "-" "R" "r" "?"	Set Backlight PWM Frequency = value/increment/decrement Reset Query	+/- 20Hz Value 100Hz : "0", "6", "4" 120Hz : "0", "7", "8" 140Hz : "0", "8", "C" 160Hz : "0", "A", "0" 180Hz : "0", "B", "4" 200Hz : "0", "C", "8" 220Hz : "0", "D", "C" 240Hz : "0", "F", "0" 260Hz : "1", "0", "4" 280Hz : "1", "1", "8" 300Hz : "1", "2", "C" 320Hz : "1", "4", "0" 340Hz : "1", "5", "4" 360Hz : "1", "6", "8" 380Hz : "1", "7", "C" 400Hz : "1", "9", "0" 420Hz : "1", "A", "4" 440Hz : "1", "B", "8"
Backlight Invert	0xe7 "0" "1" "R" "r" "?"	Set On or Off Reset Query	"0" – Off "1" – On
Red Offset for selected colour temperature	0xe8, nn "+" "-" "r" "R" "?"	Set the Offset of the red channel for the selected colour temp. = value/increment/decrement Reset Query	Red Offset for selected colour temperature.
Green Offset for selected colour temperature	0xe9, nn "+" "-" "r" "R" "?"	Set the Offset of the green channel for the selected colour temp. = value/increment/decrement Reset Query	Green Offset for selected colour temperature.
Blue Offset for selected colour temperature	0xea, nn "+" "-" "r" "R" "?"	Set the Offset of the blue channel for the selected colour temp. = value/increment/decrement Reset Query	Blue Offset for selected colour temperature.
PIP Window Auto Off	"0xee", "0x41" "0" "1" "?"	Auto Off / Auto On Query	"0"- Off "1"- On
Custom Sizing	0xef, "0" "1" "2" "?"	Custom sizing selection : Overscan / Normal / Custom Query	"0" – Overscan "1" – Custom "2" – Normal

Data Sheet

3. Other control

Function	Command	Description	Acknowledge (if enabled)
Select RS-232 acknowledge	0xc1, "0" "1"	Disable/enable command acknowledge.	"0" – acknowledge disabled. "1" – acknowledge enabled.
Auto-setup	0xc3	Start auto-setup of current vmode.	"0" – fail. "1" – successful.
Command availability	0xc4, n	Check whether a command is available.	"0" – not available. "1" – available.
Auto-calibration	0xc5	Start auto-calibration of gain of the RGB amplifier.	"0" – fail. "1" – successful.
Freeze frame	0xc6, "0" "1"	Unfreeze / freeze frame	"0" – unfreeze. "1" – freeze.
Soft Power On/Off	0xc8, "0" "1" "?"	Soft power off/on query	"0" – Turn off the LCD power and backlight. Turn off memory controller, Power down DVI Power down ADC, Power down Fclk PLL "1" – Turn on the unit
Query video input status	0xc9	Query the status of the primary & pip status	"nn,nn" = input status "nn,xx" digit = primary status: "0", "0" : invalid "A", "1" ARGB "B", "1" Composite "B", "2" Composite2 "C", "1" S-video "C", "2" S-video2 "D", "1" SD Component "D", "2" SD Component2 "E", "1" HDS DI "E", "2" HDS DI2 "F", "1" DVI "xx,nn"= PIP input status: "0", "0": invalid "A", "1" ARGB "B", "1" Composite "B", "2" Composite2 "C", "1" S-video "C", "2" S-video2 "D", "1" SD Component "D", "2" SD Component2 "E", "1" HDS DI "E", "2" HDS DI2 "F", "1" DVI
Video de-interlace method	0xca, "0" "1" "1" "R" "?"	De-interlace mode Reset Query	"3" "1"- enable AFM "3" "0"- disable AFM "4" "1"- enable TNR "4" "0"- disable TNR "5" "1"- enable MADI "5" "0"- disable MADI "6" "1"- enable LADI "6" "0"- disable LADI

Data Sheet

Query BIOS version	0xcb, "0"	Read BIOS version	BIOS version "VV.YY.ZZ" VV = V0 or E0, V0 = Release version E0 = Engineering Sample YY= Version Number ZZ= Customer Number
Query PCBA number	0xcb, "1"	Read PCBA number	"nnnnn" = PCBA number SVH-1920= "41696"
Reset parameter	0xce	Reset all parameters to default value	"1" – successful.
Wide Screen Mode Selection	0xd9, "0" "1" "2" "r" "R" "?"	Wide Screen Mode Reset Query	"0" – Normal Mode "1" – 1280x768 "2" – 1366x768

The following commands for sending texts by using RS-232 command.

Function	Command	Description	Acknowledge (if enabled)
Send Line	0xF0, "S" "LL" "TEXT" "0x0A" Return "1"	"S" = "0x53 or 0x73" Send command ----- "LL" = "0x30,0x31~0x30,0x34" Line number (Rang 0~4 lines) ----- "Text"= ASCII code, "0x20~0x7E" Character(Rang 0~34) ----- 0x0A = End of line	"S" – Send Command "LL" – Line Number "Text" – Character "0x0A" – End of Line "1" - successful.
e.g Display "Send Text" message on screen: RS232 Code:"0xF0 0x53 0x30 0x31 0x53 0x65 0x6E 0x64 0x20 0x54 0x65 0x78 0x74 0x0A" Return Code: "0xF0 0x53 0x30 0x31 0x53 0x65 0x6E 0x64 0x20 0x54 0x65 0x78 0x74 0x0A 0x31"			
Clear Line	0xF0, "C" "LL" Return "nn"	"C" = "0x43 or 0x63" Clear command ----- "LL" = "0x30,0x31~0x30,0x34" Line number (Rang 0~4 lines)	"C" – Clear command "LL" – Line Number "nn" – Return Line number
e.g. Clear Line 1 RS232 Code: "0xF0 0x43 0x30 0x31" Return Code: "0xF0 0x43 0x30 0x31 0x30 0x31"			
Text Window Horizontal Position	0xF0, "H" "ss" Return "nn"	"H" = "0x48 or 0x68" "nn" = "0x30,0x30~0x46,0x46"	"H" – Horizontal Position Command "ss" – Set Horizontal Position number "nn" – Return Position number
e.g. Set Text Window Horizontal Position RS232 Code: "0xF0 0x48 0x30 0x31" Return Code: "0xF0 0x48 0x30 0x31 0x30 0x31"			
Text Window Vertical Position	0xF0, "V" "ss" Return "nn"	"V" = "0x56 or 0x76" ----- "nn" = "0x30,0x30~0x46,0x46"	"V" – Vertical Position command "ss" – Set Vertical Position number "nn" – Return Position number

Data Sheet

e.g. Set Text Window Vertical Position RS232 Code: "0xF0 0x56 0x30 0x31" Return Code: "0xF0 0x56 0x30 0x31 0x30 0x31"			
Left offset*	0xF0, "O" "SSS" Return "nnn"	"O" = "0x4F or 0x6F" Set Left Offset command ----- "SSS" = "0x30,0x30,0x30~ 0x33,0x46,0x46" Offset Value (Rang 000~3ff)	"O" – Left Offset Command "SSS"- Offset Value (pixels) "nnn"- Return Value(pixels)
e.g. Set Left Offset = 100 pixels (0x64 (HEX)) RS232 Code: "0xF0 0x4F 0x30 0x36 0x34" Return Code: "0xF0 0x4F 0x30 0x36 0x34 0x30 0x36 0x34"			
Background Transparency*	0xF0, "B" "N" Return "n"	"B" = "0x42 or 0x62" Set Transparency Command ----- "N" = "0x30~0x46" Transparency Value (Rang 00~0F)	"B" - Transparency command "N" – Transparency Value "n"- Return Value 0x00 =opaque
Set background Transparency value is 8 RS232 Code: "0xF0 0x42 0x38" Return Code: "0xF0 0x42 0x38 0x38"			

* Note :

Please set the "Background Transparency" and "Left offset" commands before the "Send Line" command.

n = 1-byte ascii-coded hex number, e.g., parameter value of 0x1 is represented by "1" (0x31). mn or nn = 2-byte ascii-coded hex number, e.g., parameter value of 0x1e is represented by "1", "e" | "E" (0x31, 0x6e|0x4e). Please refer to the ASCII to the Hex convert table on the following page.

Data Sheet

Hex to ASCII conversion table

Hex	ASCII	Hex	ASCII	Hex	ASCII	Hex	ASCII
0x30	0	0x41	A	0x61	a	0x2B	+
0x31	1	0x42	B	0x62	b	0x2D	-
0x32	2	0x43	C	0x63	c	0x3F	?
0x33	3	0x44	D	0x64	d		
0x34	4	0x45	E	0x65	e		
0x35	5	0x46	F	0x66	f		
0x36	6	0x47	G	0x67	g		
0x37	7	0x48	H	0x68	h		
0x38	8	0x49	I	0x69	i		
0x39	9	0x4A	J	0x6A	j		
		0x4B	K	0x6B	k		
		0x4C	L	0x6C	l		
		0x4D	M	0x6D	m		
		0x4E	N	0x6E	n		
		0x4F	O	0x6F	o		
		0x50	P	0x70	p		
		0x51	Q	0x71	q		
		0x52	R	0x72	r		
		0x53	S	0x73	s		
		0x54	T	0x74	t		
		0x55	U	0x75	u		
		0x56	V	0x76	v		
		0x57	W	0x77	w		
		0x58	X	0x78	x		
		0x59	Y	0x79	y		
		0x5A	Z	0x7A	z		