

# SPECIFICATION

FOR

NORTH-AMERICAN POWER SUPPLY CORDSET (PB FR)

CORD : SVT 18/3 105°C PVC LEAD FREE

CUSTOMER : VPE/RS COMPONENTS

CUSTOMER'S PART No. : 1469127(V-NOVUS US-C13 1M)

VOLEX'S SPEC. REF. No. : 172907/26

ISSUE No. : 005

DATE : 27TH FEBRUARY 2018

CUSTOMER APPROVED :

APPROVED BY	:	
SIGNATURE	:	
APPROVED DATE	:	
No. OF PAGES	:	





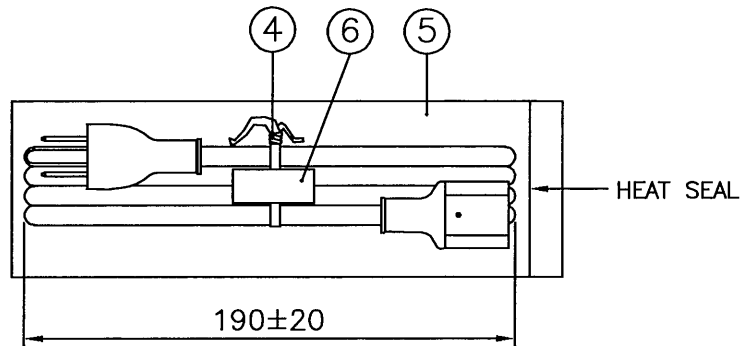
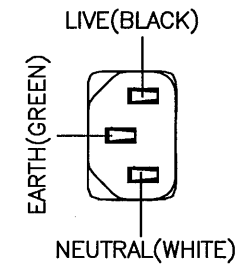
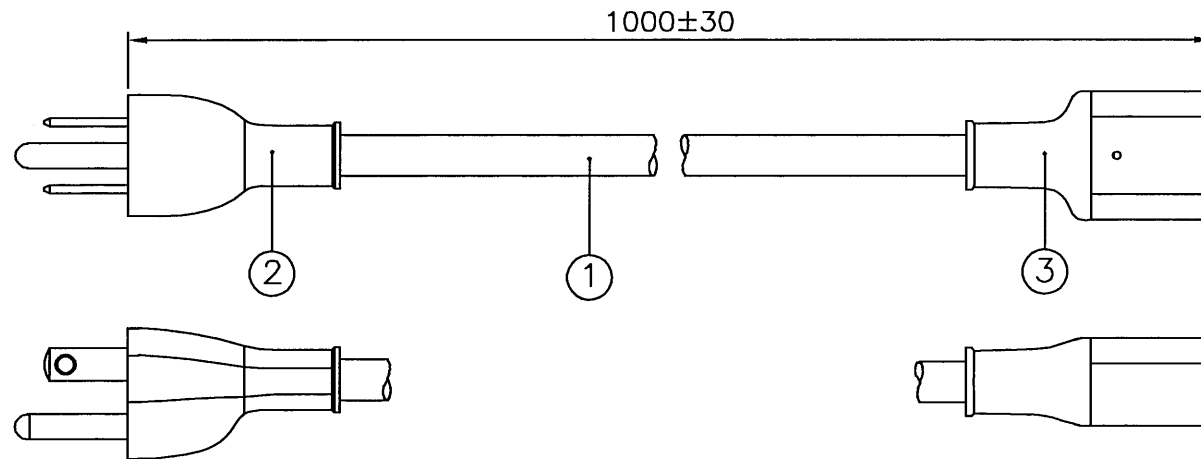
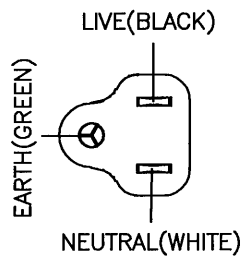

6	RS LABEL 45X25MM	L-T383	1
5	BAG LDPE 283X114X0.05 PRT (04)	904028	1
4	PE TIE BLK(REEL)	6310101	1X152MM
3	IP40G NL792B BLK	4100017	-
	MOLDED CONNECTOR VNC13S (10A 125V)	VNC13S-V	1
2	IP40G NL792B BLK	4100017	-
	MOLDED PLUG VNUS15S3 (10A 125V)	VNUS15S3-V	1
1	SVT 18/3 105°C BWG BLK PVC LEAD FREE (INDENTED)	---	1

S/N	DESCRIPTION	ITEM NUMBER	QTY
TITLE : NORTH-AMERICAN POWER SUPPLY CORDSET (PB FR)		SCALE : N.T.S.	
CUSTOMER : VPE/RS COMPONENTS		PAGE : 1/1	
CUSTOMER PART NUMBER : 1469127(V-NOVUS US-C13 1M)		ISSUE	
Reference Number : 172907/26 (EVPE02-111-18)		005	
SALES :	QA :	ENGRG :	CHECKED BY :
		<i>Alice</i>	<i>hongyan</i>
DATE :	DATE :	DATE :	DATE :
		27/02/18	27/02/18
			27/02/18

**APPROVED SOURCE FOR CABLE**

1. BAO HING(SHENZHEN). (VOLEX-ULBH-054-W)

**NOTE :**

1. ALL DIMENSIONS IN mm.
2. THE CORD SHALL COMPLY WITH NMX-J-436-ANCE + CSA C22.2 NO.49 + UL 62.
3. THE MOLDED PLUG SHALL COMPLY WITH UL498, UL817, CSA C22.2 NO.21-95.
4. THE MOLDED CONNECTOR SHALL COMPLY WITH UL817, CSA C22.2 NO.21-95 AND C22.2 NO. 182.3-M1987.
5. THIS PART CAN BE MANUFACTURED AT ANY LOCATION WHICH HAS SAFETY APPROVAL.

DRAWING NUMBER : L-T383  
 REVISION : 2

R2.0(4X)

45.0

14,6 REF

25.0



RED BACKGROUND(PANTONE 172 C)  
 WITH WHITE PRINT, SEE PICTURE BELOW

CUSTOMER P/N  
 SEE TABLE

XXXXXXXXX 1

RoHS

WHITE BACKGROUND WITH BLACK PRINT

Made in China



5

SPECIFICATION :

PRODUCT NO	AW3209 WITH PP COATING
FACESTOCK MATERIAL	ART PAPER
FACESTOCK THICKNESS	72 uM±10%
FACESTOCK COLOUR	WHITE
FACESTOCK SURFACE FINISH	GLOSSY
ADHESIVE BASE	ACRYLIC EMULSION
SHELF LIFE	1 YEAR

BARCODE: CODE 128A, SCAN SHOW CUSTOMER P/N

NOTES :

1. ALL DIMENSION IN MM.
2. GENERAL TOLERANCE ±1MM, UNLESS OTHERWISE SPECIFIED.
3.  $\diamond$  CRITICAL DIMENSIONS, WHERE Y IS IN NUMERICAL DIGITS.
4. WHITE BACKGROUND WITH BLACK PRINT.
5. FONT: ARIAL, BOLD.



PICTURE FOR COLOUR PRINT

DRAWN :	ALICE	REV	IMM/ECR	BY	DATE	REV	IMM/ECR	BY	DATE	TITLE :				
RELEASED :	2017/08/03	1	XXX	ALICE	03/08/17					RS LABEL 45X25MM				
	SIGN	DATE	2	XXX	ALICE	05/02/18				ITEM NO.:	FILENAME :	SCALE :	PROJ. :	PAGE :
CHECKED :	<i>Alice</i>									SEE TABLE	.\LABEL\PREPRINTED\L-0XXX	2 : 1		1/2
APPROVED :	<i>Alice</i>	05/02/18												

DRAWING NUMBER :

REVISION :

L-T383

2

TABLE 

CUSTOMER P/N	ITEM NO.	CUSTOMER P/N	ITEM NO.	CUSTOMER P/N	ITEM NO.	CUSTOMER P/N	ITEM NO.	CUSTOMER P/N	ITEM NO.
1247409	XXXXX	1469124	XXXXX	7440925	XXXXX	321203	XXXXX	489 217 0001	XXXXX
1468799	XXXXX	1469125	XXXXX	7440929	XXXXX	321219	XXXXX	489 346 0001	XXXXX
1468800	XXXXX	1469126	XXXXX	7440931	XXXXX	426424	XXXXX	489 352 0001	XXXXX
1468802	XXXXX	1469127	XXXXX	7440935	XXXXX	531100	XXXXX	490 217 0001	XXXXX
1468803	XXXXX	1469128	XXXXX	7440944	XXXXX	531116	XXXXX	490 223 0001	XXXXX
1468804	XXXXX	1469130	XXXXX	8188903	XXXXX	445 740	XXXXX	490 239 0001	XXXXX
1469102	XXXXX	3238517	XXXXX	8188909	XXXXX	449 297	XXXXX	490 245 0001	XXXXX
1469103	XXXXX	6151154	XXXXX	8188912	XXXXX	449 326	XXXXX	311-9321-0000	XXXXX
1469104	XXXXX	6151176	XXXXX	8188915	XXXXX	815 846	XXXXX	311-9337-0000	XXXXX
1469105	XXXXX	6151182	XXXXX	8188919	XXXXX	268 2610	XXXXX	311-9359-0000	XXXXX
1469106	XXXXX	6266593	XXXXX	9010753	XXXXX	311 9315	XXXXX		
1469107	XXXXX	6266600	XXXXX	9092156	XXXXX	2000181126	XXXXX		
1469108	XXXXX	6266616	XXXXX	9092162	XXXXX	262 1126 0001	XXXXX		
1469109	XXXXX	6266638	XXXXX	9092165	XXXXX	262 1154 0001	XXXXX		
1469110	XXXXX	6266672	XXXXX	9092168	XXXXX	262 1160 0001	XXXXX		
1469111	XXXXX	6266688	XXXXX	9092180	XXXXX	262 1176 0001	XXXXX		
1469112	XXXXX	6266694	XXXXX	9092184	XXXXX	262 1182 0001	XXXXX		
1469114	XXXXX	6266701	XXXXX	9092190	XXXXX	680 3798 0001	XXXXX		
1469115	XXXXX	6266717	XXXXX	9092193	XXXXX	426 373 0001	XXXXX		
1469116	XXXXX	6266723	XXXXX	9092196	XXXXX	426 389 0001	XXXXX		
1469117	XXXXX	6266745	XXXXX	9092200	XXXXX	426 395 0001	XXXXX		
1469118	XXXXX	7316157	XXXXX	9092203	XXXXX	426 402 0001	XXXXX		
1469119	XXXXX	7316163	XXXXX	305611	XXXXX	426 418 0001	XXXXX		
1469120	XXXXX	7316166	XXXXX	321168	XXXXX	452 669 0001	XXXXX		
1469121	XXXXX	7316175	XXXXX	321174	XXXXX	487 277 0001	XXXXX		
1469122	XXXXX	7316201	XXXXX	321180	XXXXX	487 277 0010	XXXXX		
1469123	XXXXX	7316208	XXXXX	321196	XXXXX	489 201 0001	XXXXX		

DRAWN :	ALICE	REV	IMM/ECR	BY	DATE	REV	IMM/ECR	BY	DATE
RELEASED :	2017/08/03	1	XXX	ALICE	03/08/17				
	SIGN	DATE	2	XXX	ALICE	05/02/18			
CHECKED :	<i>Alice</i>								
APPROVED :	<i>Alice</i>	05/02/18							

TITLE :	RS LABEL 45X25MM			
ITEM NO.:	SEE TABLE	FILENAME :	SCALE :	PROJ. :
		..\\LABEL\\PREPRINTED\\L-0XXX	2 : 1	
				PAGE :
				2/2

REV.	DESCRIPTION	DATE
E	ADD IN INSULATION COLOR 'BWGY'.	11/09/06
F	CHANGE COMPLIANCE STANDARD & UPDATE	05/07/07
	VALUES PER PRODUCT SAFETY.	

# 1. PVC FLEXIBLE CORD

## 1.1 SCOPE

△ This specification shall be in accordance with NMX-J-436-ANCE + CSA C22.2 NO.49 + UL 62.

## 1.2 CONSTRUCTION

CONDUCTOR	ANNEALED COPPER WIRE
INSULATION	PVC (BLACK, WHITE & GREEN) OR (BLUE, BROWN, GREEN & YELLOW) OR (BLACK, WHITE, GREEN & YELLOW)
JACKET	PVC

ITEM	UNIT	SPEC. VALUE
TEMPERATURE RATING	°C	105
MAXIMUM VOLTAGE	V	300
NO. OF CONDUCTORS	NO.	3
△ SIZE OF CONDUCTORS	mm <sup>2</sup> (AWG)	0.824 (18)
△ CONDUCTOR DIAMETER OF INDIVIDUAL WIRES	mm (in)	0.125-0.165(0.0049-0.0065)
△ MIN. AVE. THICKNESS OF INSULATION	mm (mils)	0.38 (15)
△ MIN. THICKNESS AT ANY POINT OF INSULATION	mm (mils)	0.34 (13.5)
△ MIN. AVE. THICKNESS OF JACKET	mm (mils)	0.76 (30)
△ MIN. THICKNESS AT ANY POINT OF JACKET	mm (mils)	0.61 (24)
△ OVERALL DIAMETER OF JACKET	mm (in)	5.84-6.73 (0.230-0.265)
DIELECTRIC-STRENGTH TEST- IN THE AIR 20±5°C	-	1500V for 1 min.
SPARK TEST	V/sec	3000/0.18 (For 50 Hz) 3000/0.15 (For 60 Hz)
△ INSULATION RESISTANCE AT 15°C	-	>=0.76Gohm (2.5 Mohm 1000 ft)

TITLE : CABLE SPECIFICATION  
UL/CSA APPROVED POWER SUPPLY CABLE  
SVT 18/3 105°C

SPEC NO. :	APPROVED BY :	CHECKED BY :	DRAWN BY :	REVISION :
CS-015UL	<i>[Signature]</i>	<i>[Signature]</i>	QIAN SM	F
DATE :	DATE :	DATE :	DATE :	PAGE :
05/07/07	05/07/07	05/07/07	05/07/07	1/1

REV.	DESCRIPTION	DATE
	ADD IN NEW CABLE MARKING.	
B	ADD IN 'UL/CSA' ON THE TITLE.	04/07/07
C	REMOVE OLD MARKING AS SHOWN.	27/11/08

CABLE MARKING

BAO HING (SHENZHEN)



:- (UL) SVT E159216 VW-1 300V 105°C 3X18AWG BAOHING CSA SVT  
LL112007 VW-1 300V 105°C 3X0.824mm<sup>2</sup>(18AWG) LF

DRAWN	HONGYAN	27/11/08	FILE NAME :	TITLE : CABLE MARKING  (UL/CSA)
CHECK	<i>[Signature]</i>	27/11/08	CABLE MARKING/ BAO HING/SVT/ SVT 18X3 105 -LF-BH(SZ)	
APPR	<i>[Signature]</i>	28/11/08		
SCALE	N.T.S.	REV.	c	
REFERENCE :				
SVT 18/3 105°C LF				

## 2. PLUG

REV	DESCRIPTION	DATE
BH	ADD IN CATALOGUE NO. US515AD.	02/01/18
BI	ADD IN CATALOGUE NO. MLUS15S2.	23/01/18

### 2.1. SCOPE

The specification applies to plug in compliance with UL498, UL817 and CSA C22.2 No.21-95. Except for the plug molded with SJT-R or SVT-R cable shall be in according to UL498 & UL817.

### 2.2. CONSTRUCTION

The plug construction shall comply with our catalogue No: ME301,ME301R,ME301P, ME301RP,ME301S,ME302,ME302P,ME302GR,ME302GRP,PS204,PS204A,PS204D, PS204GR,PS206,MP204,VS205A,VS205S,VS207A,VS208A,US15B,US15BP,US115PSC, US115SC,US115LS,US115LPS,USJ15B,US115S,USI515A,US515SC,PS520,PS620, PS206A,926,926SR,US650A, US515A , US115VPS2, US15S3, US15S2, MA115VPS2, 926BSR, 926NPSR, US515BTA3, 953, USJ15TS3, US15GPS2, US115DPS2, VPUS15S3, PL-3001,VPUS15DS3, PS520A, CX-394S, VPUS15S2, USD15GPS2, USD115PS2, APUS15S3, DS15PS2, APUS15S2, DS15FPS2, DS15EPS2, DS15JPS2 , US520A3 DS15FBPS2 ,MFUS15S2, HO515S3,DLUS15S3, VNUS15S2, LSUS15THA3, USL515PS3, VNUS15S3, VNUS15FS3, CSUS15S3, DGUSJ15HS3, US515AD & *MLUS15S2* .

### 2.3. CHARACTERISTICS

NO.	TEST ITEM	DESCRIPTION	ACCEPTANCE CRITERIA
1.	Conductor secureness test	A force of 20lbf (89N) is applied on the connection between the blade and conductor for 1 min.	The connection shall not break.
2.	Strain relief test (May be exempted with abrupt pull test)	A pull of 30lbf (133N) is applied between the cord and fitting for 1 min.	There shall not be any damage to the cord and fitting. For hospital grade plug, the cord shall not be displaced by more than 0.8mm.
3.	Insulation resistance test	A D.C 500V is applied to the following; i) between live parts of opposite polarity for Class I & Class II plugs. ii) between live parts and grounded parts for Class I plug only. iii) between live parts and exposed surfaces for Class I & Class II plugs.	Min. 100 M Ohm
4.	Temperature rise test	A rated current is passed through the cord for 4 hours.	The rise in temperature of the blades shall not exceed 30°C.
5.	Dielectric voltage withstand test	An alternating voltage of 1250V is applied between each conductors for 1 min.	There shall be no arching, breakdown or flashover
6.	Accelerated aging test	The sample is placed in an oven at a temperature of 100±1°C for 96 hours.	There shall be no damage.
7	Crushing test	After ageing for 7 days at 90±1°C, a pressure of 75lbf (334N) (500lbf for hospital grade) shall be applied on the fitting for 1 min.	The shall be no damage and expose of live parts.

DRAWN:	SANDY YU	23/01/18	TITLE : NORTH-AMERICAN PLUG
CHECK:	<i>hongyan</i>	23/01/18	
APPR:	<i>heath</i>	23/01/18	
REV:	BI		
REFERENCE:			



NO.	TEST ITEM	DESCRIPTION	ACCEPTANCE CRITERIA
8	Flexing test (applicable only to parallel cord)	The sample is secured on an oscillating member with a weight of 284g(HPN cord) or 113g(others) and moved backward and forward through an angle of 180° (90° on each vertical side) for 2500 cycles. Rate of cycle is 10/min. and each cycle is from the left to the right and back again.	The conductors on each core shall not have been completely broken.
9	Abrupt pull test	i) Cords with grounding conductor. The plug is inserted into a receptacle with grounding pin on the up position. The angle is 45°. The blades are secured with set screws. A weight of 2.5lb (1.1Kg) is impacted by pulling on the cord for 25 times dropped at height of 10 inches (254mm).A current of 40A at 6-12V is then applied to the grounding conductor for 2 mins. ii) Cords with two conductors. Similar to item (i) but with only 5 impacts and the height is 7 inches (178mm).	No open circuit of any conductors.
10	Abrupt removal test (Hospital grade only)	The preparation is similar to item (9i) but the angle is at 90° and the blades are not secured. A 10lb (4.5Kg) weight is dropped from a height of 24 inches (610mm).	The plug shall be completely removed from the receptacle.
11	Jacket retention test	i) Similar to item (9i) but with only 10 impacts. ii) Similar to item (12) but the 15lbf(67N) is applied at 8 inches from the cord entrance. A weight of 3 lb(1.33kg) is then suspended 8 inches from the cord entrance for 15s. It is then rotated 360° in 15s.	No fillers, separators, insulation or bare conductors shall be seen on the cord entrance area.
12	Security of insulation test (Applicable to parallel cord only)	Insulation on each conductor is slitted open at approx. 25mm from it's entry. All strands of conductor are to be severed. A pull of 15lbf (67N) is applied for 2 min between all blades and free end of the cord.	There shall not be any detachment of insulation from the plug or baring of conductors.
13	Blade pull test at elevated temp.	The sample is conditioned at 60°C. A 10lbf (44.5N) pull is applied to the blades in succession for 4 hours at 60°C. The weight is then removed and the sample is allowed to cool to room temperature.	The blades must not be displaced by more than 1.6mm.
14	Security of blades test	A force of 20lbf (89N) is applied for 2 min. at each blade in succession.	After the removal of the weight, the blades shall not be displaced by more than 2.4mm.

DRAWN:	SANDY YU	23/01/18	TITLE : NORTH-AMERICAN PLUG
CHECK:	<i>hongyan</i>	23/01/18	
APPR:	<i>Keith</i>	23/01/18	
REV:	BI		

NO.	TEST ITEM	DESCRIPTION	ACCEPTANCE CRITERIA
15	Impact Resistance Test	After ageing for 7 days at 90±1°C, the fitting is allowed to cool to room temperature. The fitting with a cable length of about 45 in (1143 mm) is to be mounded on a vertical wall with the plug hanging freely along a striking block. The plug is lifted vertically up but about 36 in (965 mm) away from the wall. The plug is then let go and be allowed to strike the block. This is to be repeated 1000 times.	There shall be no damage to the fitting.
16	Rotary Pull (applicable only to hospital grade)	The plug is moulded with the flexible cord without the conductors terminated to the blades or grounding pin. The cord is then subjected to a vertical force of 10lbf (44.5N) and rotated at a rate of 9rpm in a 3 in diameter circle at a point 6 in (152mm) below the cord exit for 2 hours.	The conductors shall not have been displaced by more than 0.8mm.
17	Adhesion test (applicable only to outdoor-use)	Adhesion between the cord and the body of the fitting shall be determined by bending the cord to an angle of 90° with the plane of the cord entry.	<p>The area shall be examined visually for openings that would likely permit the entry of moisture into the body.</p> <p>If the visual examination cannot verify that acceptable adhesion exists, the plug may be cut apart for examination. The adhesion may be determined to be acceptable if the examination of the inner construction reveals a positive seal at all points around the periphery of the cord.</p>
18	Weather (sunlight) resistance test (applicable only to outdoor-use)	If the plastic material is not tested for weather resistance, then the plugs/connectors/assemblies shall be subjected to conditioning according to CSA C22.2 No. 2556 or CSA C22.2 0.17 for 720 hrs (carbon arc) or 1000 hrs (Xenon-arc), and then subjected to crushing and impact resistance test.	<p>After crushing test, there shall be no damage and expose of live parts.</p> <p>After impact resistance test, there shall be no damage to the fitting.</p>

DRAWN:	SANDY YU	23/01/18	TITLE : NORTH-AMERICAN PLUG
CHECK:	<i>hongyan</i>	23/01/18	
APPR:	<i>heith</i>	23/01/18	
REV:	BI		
REFERENCE:			

### 3. CONNECTOR

REV	DESCRIPTION	DATE
BC	ADD IN CATALOGUE NO. VAC5AL.	20/06/17
BD	ADD IN CATALOGUE NO. MLC7S.	23/01/18

#### 3.1. SCOPE

The specification applies to connector in compliance with UL817, CSA C22.2 No. 21-95 and C22.2 No. 182.3-M1987.

The connector shall generally complies to IEC 60320-1 with the exception of catalogue no. PS309/P & MS212A.

#### 3.2. CONSTRUCTION

The connector construction shall comply with our catalogue No: VAC5S, VAC5AR, 25AC5, APC5A, APC5M, APC5S, APC5SM, APC5SP, APC7S, APC7Q, APC7M, VAC7S, SZC7S, APC13, APC13S, VSCC13, AVL13, VAC7A, VAC7PS, VIC13A, M1625, V1625, V1625LA, V1625A, V1625BA, V1625BS, VAC15S, VAC15BS, VAC17S, VAC17BS, PIC17BS, PIC17S, VAC19, VAC19A, VSC19, DLC5A3, DLC5SA3, PS625, PS625A, MS225, PS309, PS309P, MS212, MS212A, APC13F, APC13G, DLC7U2, AP7M16, 386A, VAC17A, VAC13KS, DLC5U3, VCC13, VAC19KS, DLC7E2, DLC5E3, HPC13A, V1625AT, CN-4001, SOC7S, APC5SF, VCC5S, VCC7S, APC7H, APC13H, V1625H, VAC19H, APC7K, APC13FH, APC13HC, MFC7S, VAC15A, 386AL, VAC17KS, APC7HB, VAC13CS, VAC13AD, VAC13AU, DLC5CS3, VNC7S, VNC13S, VNC5S, VNC13A, VNC7A, VNC5FS, DGC13S, DGC13A, DGC19S, VAC5AL & **MLC7S**.

#### 3.3. CHARACTERISTICS

NO.	TEST ITEM	DESCRIPTION	ACCEPTANCE CRITERIA
1.	Conductor secureness test	A force of 20lbf (89N) is applied on the connection between the contact and conductor for 1 min.	The connection shall not break.
2.	Strain relief test	A pull of 30lbf (133N) is applied between the cord and fitting for 1 min.	There shall not be any damage to the cord and fitting.
3.	Insulation resistance test	A D.C 500V is applied between conductors and between current carrying parts and body.	Min. 100 M Ohm
4.	Temperature rise test	A rated current is passed through the cord for 4 hours.	The rise in temperature of the contacts shall not exceed 30°C.
5.	Dielectric voltage withstand test	An alternating voltage of 1250V is applied between each conductors for 1 min.	There shall be no arching breakdown or flashover
6.	Accelerated aging test	The sample is placed in an oven at a temperature of 100±1°C for 96 hours.	There shall be no damage.
7.	Flexing test (applicable only to parallel cord)	The sample is secured on an oscillating member with a weight of 284g(HPN cord) or 113g(others) and moved backward and forward through an angle of 180° (90° on each vertical side) for 2500 cycles. Rate of cycle is 10/min. and each cycle is from the left to the right and back again.	The conductors on each core shall not have been completely broken.

DRAWN:	SANDY YU	23/01/18	TITLE : NORTH-AMERICAN CONNECTOR
CHECK:	<i>hongyan</i>	23/01/18	
APPR:	<i>heith</i>	23/01/18	
REV:	BD		
REFERENCE:			

NO.	TEST ITEM	DESCRIPTION	ACCEPTANCE CRITERIA
8.	Jacket retention test	Insulation on each conductor is slitted open at approx. 25mm from cord entry. All strands of conductor are to be severed. A pull of 15lbf (67N) is applied for 2 min. between fitting and free end of cord.	There shall not be any detachment of insulation from the connector.

DRAWN:	SANDY YU	23/01/18	TITLE : NORTH-AMERICAN CONNECTOR
CHECK:	<i>hongyan</i>	23/01/18	
APPR:	<i>Keith</i>	23/01/18	
REV:	BD		
REFERENCE:			

REV.	DESCRIPTION	DATE
A	INITIAL RELEASE.	22/04/15
B	ADD IN CURRENT OF '2.5A'.	23/09/15

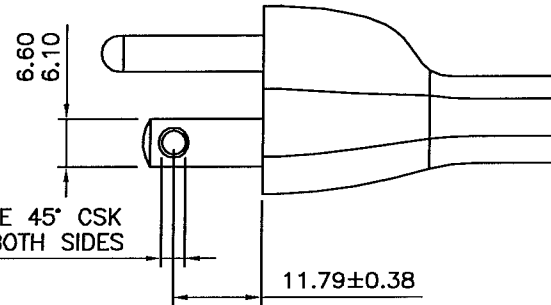
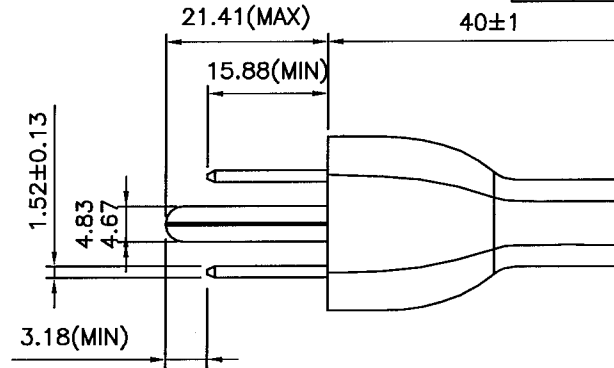
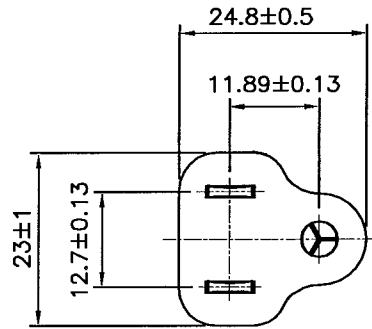

∅3.18±0.13 HOLE 45° CSK  
3.96±0.13 DIA BOTH SIDES

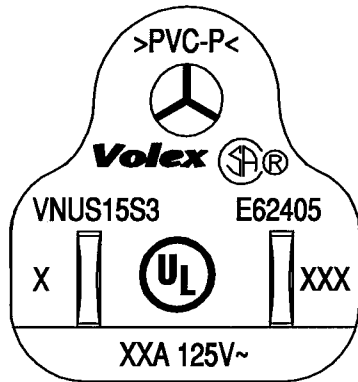
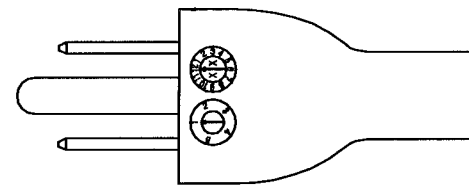

MARKING DETAILS

TABLE :

CURRENT (XXA)	10A	2.5A
		✓



NOTES :

- 1) ALL DIMENSIONS IN mm.
- 2) X - CAVITY NO. (OPTIONAL)
- 3) XXX - MANUFACTURING LOCATION.
- 4) XXA 125V~ - RATING. (REFER TO TABLE)
- 5) VENDOR'S TRADEMARK MUST BE ON THE BLADE.
- 6) YEAR & MONTH & WEEK CODE INSERT :

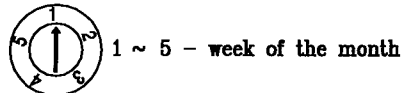

SM	HENG GANG (CHINA)	X	DRAWN	LILY ZHOU	23/09/15	FILE NAME :	TITLE :	
SM1/SMI	ZHONGSHAN (CHINA)	X	CHECK	Wib	23/09/15	A-PLUG/UL&CSA	MOLDED PLUG VNUS15S3	
VH	HANOI (VIETNAM)	X	APPR	Wjm	23/09/15	GENERAL/VNUS15S3 -UL&CSA		
B	BATAM (INDONESIA)	X	REV.	B	SCALE	N.T.S.		
VC	CHENNAI (INDIA)	X	REFERENCE :					
MANUFACTURE LOCATION MARK ('X' IS APPLICABLE ONLY)			NORTH-AMERICAN APPROVAL					

REV.	DESCRIPTION	DATE
A	INITIAL RELEASE.	22/04/15
B	ADD IN RATING '12A & 13A & 250V' AS SHOWN.	27/06/15

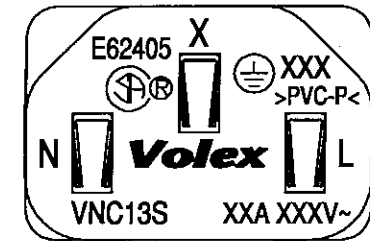
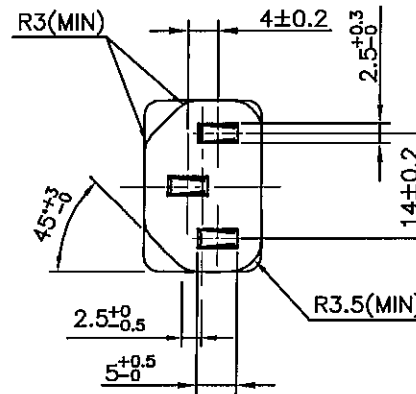
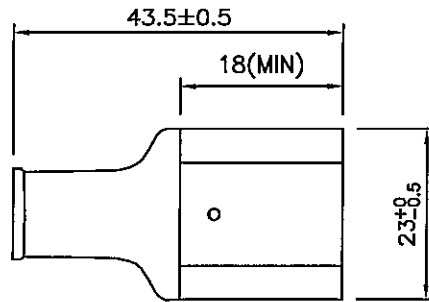

MARKING DETAILS :

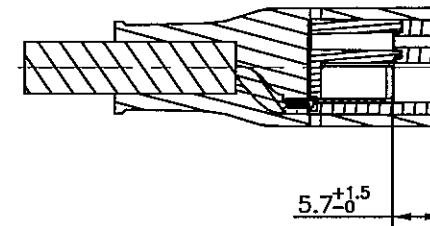
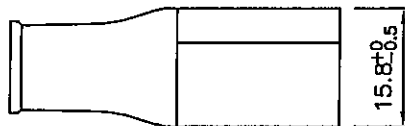

TABLE :

CURRENT (XXA)	10A	12A	13A
	VOLTAGE (XXXV~)	125V~	250V~



NOTES :

- 1.) ALL DIMENSIONS IN mm.
- 2.) X - CAVITY NO. (OPTIONAL)
- 3.) XXA XXXV~ - RATING. (REFER TO TABLE)
- 4.) XXX - MANUFACTURING LOCATION.

SM	HENG GANG (CHINA)	X	DRAWN	TAN SHAO	27/06/15	FILE NAME :	TITLE :	
SM1/SMI	ZHONGSHAN (CHINA)	X	CHECK	Tiashuo	27/6/15	A-CONNECTOR/ UL/CSA/GENERAL /VNC13S-UL-CSA	MOLDED CONNECTOR VNC13S	
VH	HANOI (VIETNAM)	X	APPR	Feng	27/6/15			
B	BATAM (INDONESIA)	X	REV.	B	SCALE	N.T.S.		
VC	CHENNAI (INDIA)	X	REFERENCE :					
MANUFACTURE LOCATION MARK ('X' IS APPLICABLE ONLY)			NORTH-AMERICAN APPROVAL					