

# Accessories

Connection of motor and encoder	Couplings	Bellows and spring washer couplings
---------------------------------	-----------	-------------------------------------



**Bellows couplings provide cost-effective connection of the motor and encoder. They are also able to correct any angular errors between the drive and encoder.**

**Spring washer couplings are used with high speeds.**

<b>Order code</b>	<b>Couplings</b>	8.0000 . 1 XXX . XX XX
		Type <b>a</b> <b>b</b> <b>c</b>
<b>a</b> Type of coupling	<b>b</b> Bore diameter d1 (see technical data)	Example: d1 = 10 mm [0.39"] and d2 = 12 mm [0.47"] Order no. = 8.0000.1X0X.1012
102 = Bellows-type ø 19 mm [0.75"]	Note: for the bore diameter d1 = 1/4" please enter Code A2	
202 = Bellows-type ø 15 mm [0.59"]		
301 = Spring washer type, ø 30 mm [1.18"], one-part		
401 = Spring washer type, ø 30 mm [1.18"], three part, plug-in		
502 = Bellows-type ø 25 mm [0.98"]	<b>c</b> Bore diameter d2 (see technical data)	

Technical data			8.0000.1102.XXXX	8.0000.1202.XXXX	8.0000.1301.XXXX	8.0000.1401.XXXX	8.0000.1502.XXXX
<b>Type</b>							
<b>Maximum speed</b>	min <sup>-1</sup>	10000	10000	12000	12000	10000	
<b>Maximum torque</b>	Ncm	120	40	80	60	200	
<b>Maximum displacement</b>	radial	mm ± 0.3	± 0.25	± 0.4	± 0.3	± 0.35	
	axial	mm ± 0.5	± 0.45	± 0.4	± 0.4	± 0.54	
	angular	- ± 4°	± 4°	± 3°	± 2.5°	± 4°	
<b>Torsion spring stiffness</b>	Nm/rad	150	85	150	30	183	
<b>Radial spring stiffness</b>	N/mm	10	20	6	40	17.8	
<b>Moment of inertia</b>	gcm <sup>2</sup>	9.5	2.1	19	35	20	
<b>Max. tightening torque</b>	Ncm	150	70	80	80	120	
<b>Working temperature</b>		-30°C ... +120°C [-22°F ... +248°F]	-30°C ... +120°C [-22°F ... +248°F]	-30°C ... +120°C [-22°F ... +248°F]	-10°C ... +80°C [+14°F ... +176°F]	-30°C ... +120°C [-22°F ... +248°F]	
<b>Weight approx.</b>		16 g [0.56 oz]	6.5 g [0.23 oz]	16 g [0.56 oz]	30 g [1.06 oz]	24 g [0.85 oz]	
<b>Material</b>	flange bellow or spring washer/casing	Al, anodised stainless steel	Al, anodised stainless steel	Al, anodised stainless steel	Al, anodised PA 6.6 gf.	Al, anodised stainless steel	
<b>Diameter d/d1 from ... to</b>	mm [inch]	3 ... 12 [0.12 ... 0.47]	3 ... 9 [0.12 ... 0.35]	3 ... 8 [0.12 ... 0.32]	4 ... 16 [0.16 ... 0.47]	3 ... 16 [0.12 ... 0.63]	
<b>Standard bore diameter</b>	(d1 / d2) mm [inch]	12 / 12 [0.47 ... 0.47]	08 / 06 [0.32 ... 0.24]	06 / 06 [0.24 ... 0.24]	12 / 12 [0.47 ... 0.47]	15 / 12 [0.59 ... 0.47]	
		12 / 10 [0.47 ... 0.39]	06 / 06 [0.24 ... 0.24]		12 / 10 [0.47 ... 0.39]	14 / 12 [0.55 ... 0.47]	
		10 / 10 [0.39 ... 0.39]	06 / 04 [0.24 ... 0.16]		10 / 10 [0.39 ... 0.39]	14 / 10 [0.55 ... 0.39]	
		10 / 08 [0.39 ... 0.32]	04 / 04 [0.16 ... 0.16]		10 / 06 [0.39 ... 0.24]	10 / 10 [0.39 ... 0.39]	
		10 / 06 [0.39 ... 0.24]			06 / 06 [0.24 ... 0.24]	06 / 06 [0.24 ... 0.24]	
		08 / 08 [0.32 ... 0.32]			1/4" / 10		
		06 / 06 [0.24 ... 0.24]			1/4" / 06		

## Description and applications

Manufacturing and installation tolerances as well as the effects of temperature cause alignment errors between shafts in drive engineering which can sometimes lead to extreme overload on the bearings.

This may result in increased wear of the bearings and may lead to premature failure of the encoder. By using couplings, these alignment errors can be compensated, thereby reducing the load on the bearings to a minimum. A distinction should be made between three different kinds of alignment error: radial, angular and axial displacement.

Whilst with torsion-free but flexible shaft couplings, axial shaft displacements produce only static forces in the coupling, radial and angular displacements produce alternating stresses, restoring forces and moments which may have an impact on adjoining components (shaft bearings).

Depending on the type of coupling, particular attention should be paid to radial shaft displacement which should be kept to a minimum.

# Accessories

<b>Connection of motor and encoder</b>	<b>Couplings</b>	<b>Bellows and spring washer couplings</b>
--	------------------	--

## Metal bellows-type couplings (.1102, .1202 und .1502)

Metal bellows-type couplings are recommended as an inexpensive type of coupling. They are also suitable for compensating larger angle displacements.

### Dimensions

Dimensions in mm

Bellows-type coupling  $\varnothing 15$  [0.59]  
(8.0000.1202.XXXX)

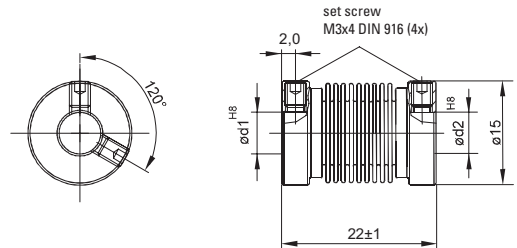

Bellows-type coupling  $\varnothing 19$  [0.75]  
(8.0000.1102.XXXX)

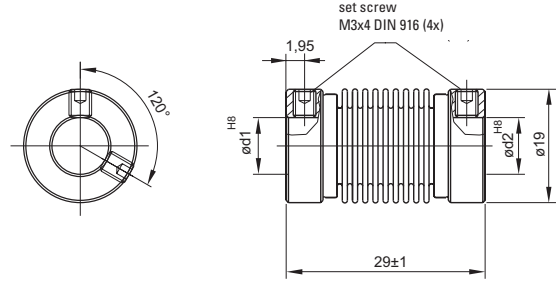

Bellows-type coupling  $\varnothing 25$  [0.98]  
(8.0000.1502.XXXX)

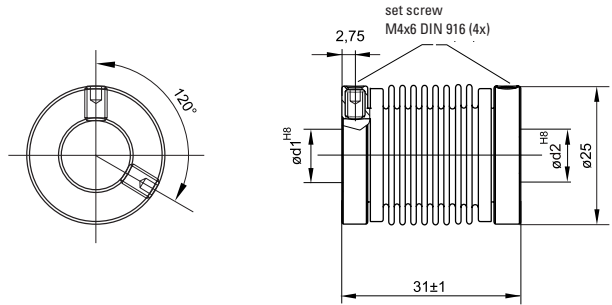

## Spring washer-type couplings (.1301 und .1401)

Spring washer couplings are used primarily where high speeds and minimal axial errors occur. For applications requiring potential separation between the encoder and the drive, use the electrically isolating spring washer coupling.

Spring washer-type coupling, one-part  
(8.0000.1301.XXXX)

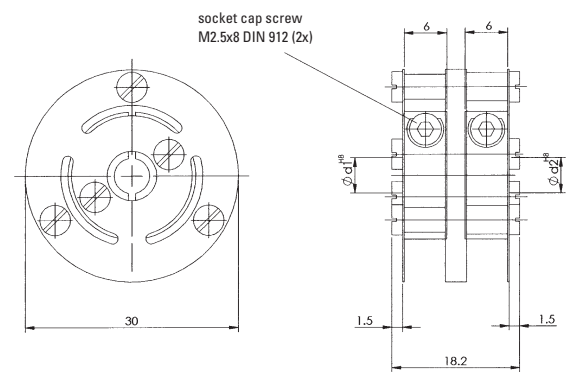

Spring washer-type coupling, three part, plug-in  
(8.0000.1401.XXXX)

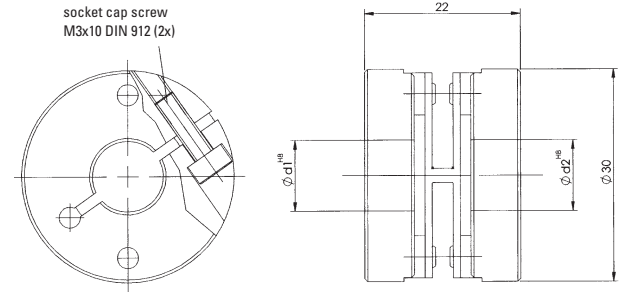

### Installation instructions

1. Check shaft for displacement; see technical data for details.
2. Align and adjust coupling on shafts.
3. Tighten locking screws carefully. Avoid overtightening.
4. During installation protect the coupling from damage and from overbending.

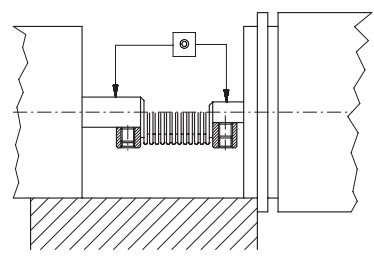

# Accessories

**Connection of motor and encoder**      **Flexible shaft coupling**      **Double loop coupling**



The safe, uncomplicated and economical solution, if drive shafts with angular, radial and/or axial displacement are to be friction-locked together.

**Order no. size 1**

Bore diameter both sides 6 mm [0.24"]      **8.0000.1J01.0606**

**Order no. size 2**

Bore diameter both sides 10 mm [0.39"]      **8.0000.1K01.1010**  
 Bore diameter 11 mm [0.43"] and 12 mm [0.47"] with keyway      **8.0000.1L01.1112**

Technical data		
	Size 1	Size 2
<b>Max. speed</b>	3000 min <sup>-1</sup>	3000 min <sup>-1</sup>
<b>Max. torque</b>	0.5 Nm	2.0 Nm
<b>Max. offset of shafts</b>	radial ± 2 mm axial ± 2 mm angular ± 10°	± 3 mm ± 4 mm ± 12°
<b>Torsion spring stiffness</b>	13 Nm/rad	28 Nm/rad
<b>Radial spring stiffness</b>	13 N/mm	7 N/mm
<b>Moment of inertia</b>	41 gcm <sup>2</sup>	106 gcm <sup>2</sup>
<b>Max. clamping torque</b>	100 Ncm	100 Ncm
<b>Weight, approx.</b>	33 g [1.16 oz]	85 g [3.35 oz]
<b>Temperature range</b>	-30°C ... + 80°C [-22°F ... +176°F]	
<b>Material</b>	flange connecting element	steel galvanized Polyurethane

### Functional principle

Compensation of an angular misalignment      Compensation of a radial misalignment

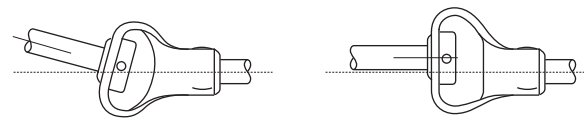

Compensation of a axial misalignment

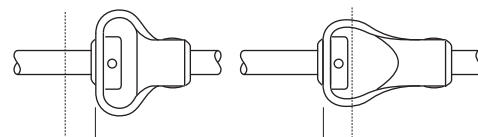

### Dimensions

Dimensions in mm

Size 1

6 / 6  
[0.24 / 0.24]

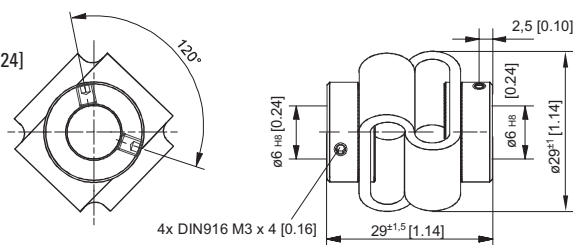

Size 2

11 / 12 [0.43 / 0.47]  
with keyway

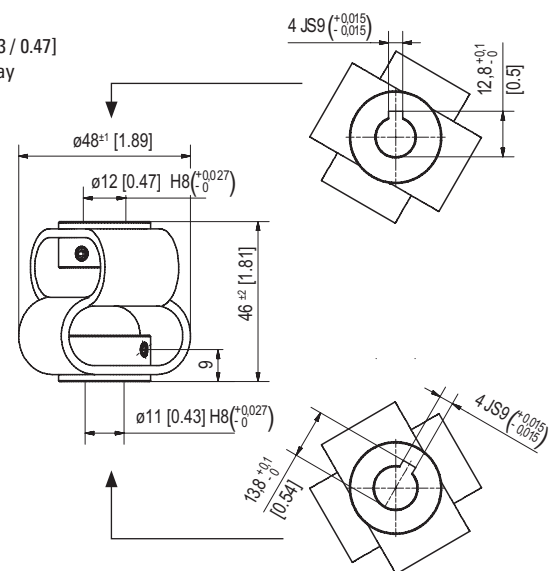

Size 2

10 / 10  
[0.39 / 0.39]

