

## LA100B DATA & APPLICATION NOTES

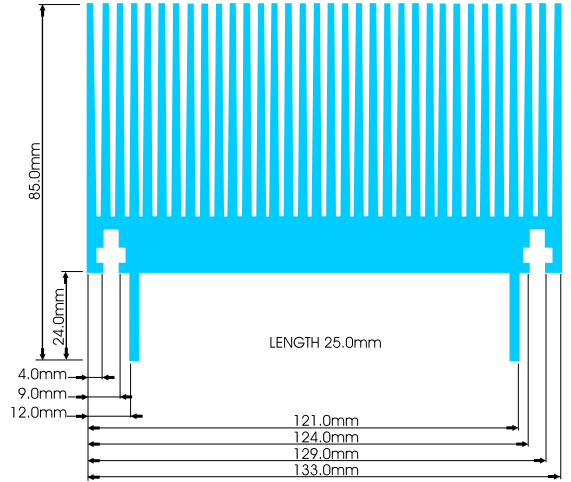
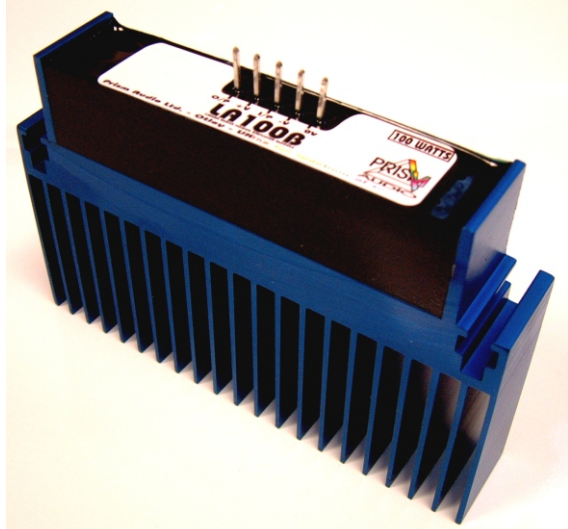

### ● SPECIFICATION / FEATURES

THE PRISM LA100B IS AN ENCAPSULATED AND ELECTRONICALLY PROTECTED POWER AMPLIFIER MODULE. THE CIRCUIT USES COMPONENTS OF THE HIGHEST QUALITY AND IS ASSEMBLED USING PREDOMINANTLY SURFACE MOUNT COMPONENTS. THE INNOVATIVE DESIGN RESULTS IN A VERY RUGGED MODULE THAT ALSO EXHIBITS EXCELLENT SONIC QUALITIES.

#### FEATURES

- 4 OR 8 OHM OPERATION
- WIDE FREQUENCY RESPONSE
- SHORT CIRCUIT OVERLOAD PROTECTION
- OUTPUT S.O.A. PROTECTION
- PSU AVAILABLE SEPARATELY

#### SPECIFICATION

- |                             |                   |
|-----------------------------|-------------------|
| ● OUTPUT POWER (4OHMS)      | 100W (RMS)        |
| ● FREQUENCY RESPONSE (-3dB) | 5Hz - 50KHz       |
| ● THD @ 1KHz                | 0.015%            |
| ● S/N RATIO                 | 100dB             |
| ● SLEW RATE (TYPICAL)       | 15V/ $\mu$ SECOND |
| ● INPUT SENSITIVITY         | 500mV (RMS)       |
| ● DAMPING FACTOR            | >200              |
| ● SUPPLY VOLTAGE (MAX)      | +/- 45VOLTS       |

### ● APPLICATION NOTES

TO POWER THE LA100B AMPLIFIER MODULE YOU WILL NEED A SYMMETRICAL DC POWER SUPPLY WITH AN OUTPUT RANGE BETWEEN  $\pm 30V$  AND  $\pm 40V$  NOMINAL. WE RECOMMEND THE USE OF THE PRISM AUDIO PSU100 POWER SUPPLY.

- FOR 8 OHM OPERATION, ONE POWER SUPPLY WILL SUPPLY TWO LA100B MODULES.

- FOR 4 OHM OPERATION, ONE POWER SUPPLY PER LA100B MODULE IS REQUIRED.

THE WIRING BETWEEN THE POWER SUPPLY AND THE LA100B MODULE SHOULD BE AS SHORT AS POSSIBLE. IF CONNECTIONS EXCEED 150mm THEN TWO EXTRA ELECTROLYTIC CAPACITORS ARE REQUIRED TO 'LOCALLY' DECOUPLE THE LA100B MODULE - SEE BELOW.

THE AMPLIFIER SHOULD BE INSTALLED HORIZONTALLY (FINS VERTICAL) TO ALLOW COOLING AIR TO CIRCULATE THROUGH THE FINS - GOOD AIR FLOW IS VERY IMPORTANT, PARTICULARLY WHEN USING THE AMPLIFIER WITH 4 OHM LOADS.

IF THE MODULE IS COOLED WITH A FAN, INSIDE A PIECE OF EQUIPMENT, MAKE SURE WARM EXHAUST AIR CAN EXIT THE ENCLOSURE WITHOUT BEING RECIRCULATED INTERNALLY.

THE AMPLIFIER IS PROTECTED ELECTRONICALLY AGAINST SHORT TERM OVERLOADS AT THE OUTPUT. DO NOT OPERATE THE AMPLIFIER IF YOU SUSPECT A FAULTY LOAD.

PROLONGED OVERLOAD WILL CAUSE PERMANENT MODULE DAMAGE.

CERTAIN REACTIVE LOADS, EITHER VERY CAPACITIVE OR VERY INDUCTIVE CAN CAUSE INSTABILITY AND/OR OVER DISSIPATION - ALWAYS CHECK THE RUNNING TEMPERATURE OF THE MODULE. IF THE HEATSINK TEMPERATURE EXCEEDS 85C USE A COOLING FAN.

IF YOU DO NOT USE A PRISM PSU100 POWER SUPPLY, BE CAREFUL NOT TO LET THE OFF LOAD VOLTAGE EXCEED  $\pm 45$  VOLTS.

IF A REGULATED POWER SUPPLY IS USED, BE SURE NOT TO LET IT EXCEED  $\pm 36$  VOLTS.

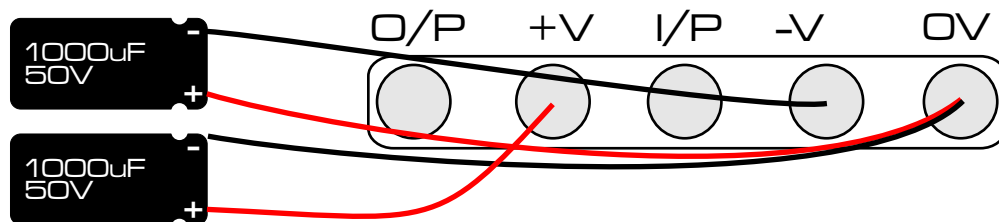

## ● APPLICATIONS INFORMATION

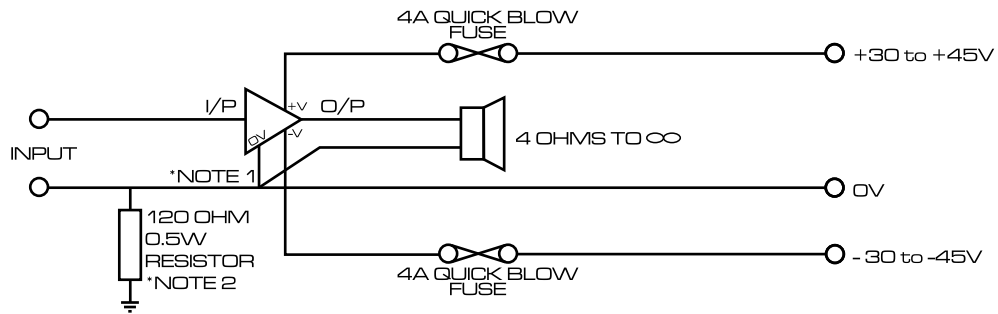

### NOTE 1

STAR EARTH POINT - THIS IS IDEALLY THE MID POINT OF THE POWER SUPPLY BULK STORAGE CAPACITORS. THESE SHOULD BE SITUATED AS CLOSE TO THE MODULE AS POSSIBLE. THE POSITIVE AND NEGATIVE SUPPLY LINES SHOULD ALSO BE AS SHORT AS POSSIBLE.

### NOTE 2

EARTH LOOP STOPPER RESISTOR - 0.5W

### NOTE 3

IF SOLDERING TO THE MODULE PINS, DO NOT ALLOW THE SOLDER ON THE END OF THE PIN TO REMAIN MOLTEN FOR MORE THAN 3 SECONDS

### NOTE 4

IF A REGULATED POWER SUPPLY IS USED, THE VOLTAGE SHOULD NOT EXCEED  $\pm 36$  VOLTS

## ● TYPICAL LA 100B POWER SUPPLY

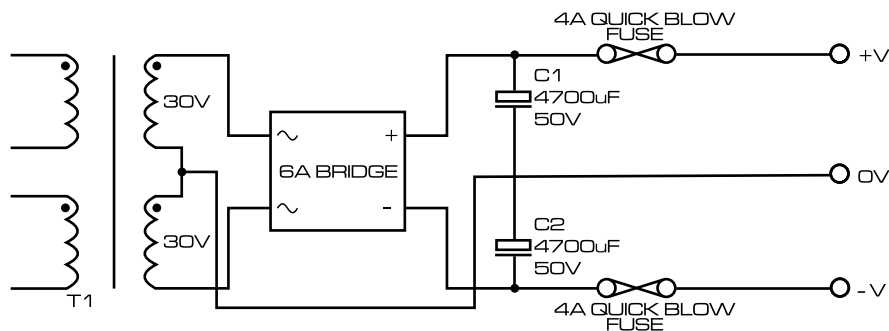

T1 = 100VA 30-0, 30-0  
C1/C2 = 4700uF 50V ELECTROLYTICS  
BRIDGE = 6A 200V PIV

THE MAINS INPUT PRIMARY MUST BE PROTECTED BY A HBC CERAMIC FUSE. A 2.5A RATING IS SUGGESTED.

### NOTE 5

THE MODULE SHOULD BE MOUNTED VERTICALLY IN FREE AIR SO THAT AIR CAN PASS THROUGH THE FINS. IF THE MODULE IS USED ON NORMAL MUSIC, NO EXTRA COOLING IS NORMALLY REQUIRED. HOWEVER, FOR SOME APPLICATIONS OR IN INSTALLATIONS WHERE THE MODULE IS FITTED INTERNALLY, A COOLING FAN WILL BE REQUIRED.

### NOTE 6

NO INPUT COUPLING CAPACITOR IS REQUIRED

### NOTE 7

ALWAYS USE A QUICK BLOW FUSE (4A) IN BOTH SUPPLY RAILS TO PROTECT THE LOAD IN THE EVENT OF A FAULT WHICH PRESENTS DC TO THE LOAD.

### NOTE 8

ALWAYS RETURN ALL 0V CONNECTIONS TO THE POWER SUPPLY.

### NOTE 9

IF THE MODULE IS USED WITH AN OUTPUT TRANSFORMER, THE LOAD MUST BE DC ISOLATED FROM THE MODULE.



C1 AND C2 ARE 1000uF 63V ELECTROLYTIC CAPACITORS FOR AN 8 OHM LOAD AND A FREQUENCY RESPONSE DOWN TO 50Hz. TO AVOID TRANSFORMER SATURATION, DO NOT USE HIGHER VALUE CAPACITORS.

FOR THE SAME RESPONSE AT 4 OHMS, USE 2200uF 63V ELECTROLYTIC CAPACITORS. DAMAGE TO THE MODULE COULD OCCUR IF THE TRANSFORMER IS ALLOWED TO SATURATE.