

LOC		DIST		REVISIONS			
P	LTR	DESCRIPTION	DATE	DN	APVD		
	U1	REVISED PER 0G3B-1094-04	19JAN05	KW	SR		
		REVISED PER ECO-10-000443	15JAN10	KK	AEG		

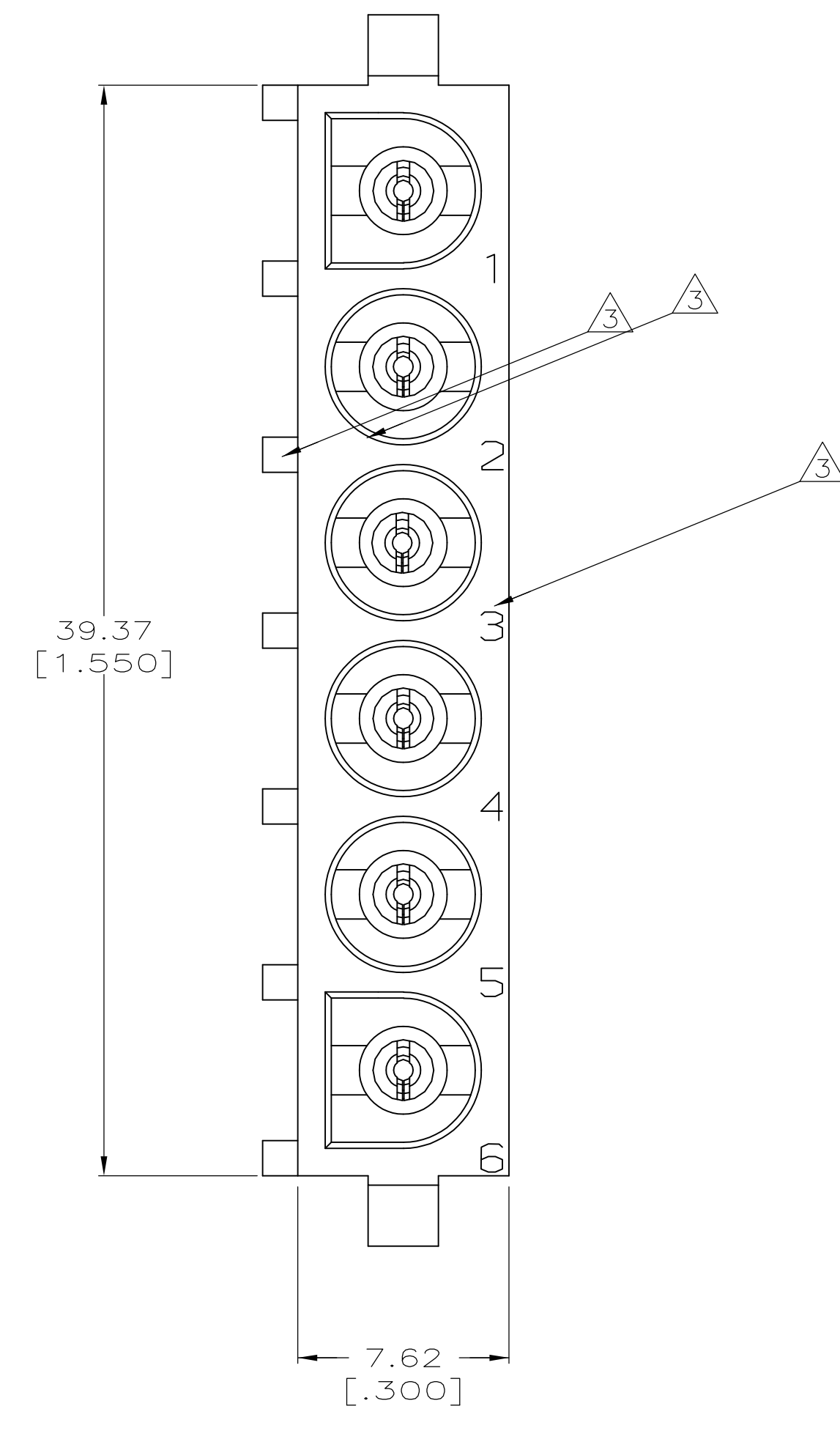

- PARTS COMPLY TO AMP SOLDERABILITY SPECIFICATION 109-11-3.
- CONTACT IS PLATED OVERALL WITH 0.00127 [.000050] NICKEL, THEN 0.00076 [.000030] GOLD OVER CONTACT LENGTH INDICATED AND MATTE TIN LEAD ON SOLDER TAIL END.
- CIRCUIT IDENTIFICATION CHARACTERS ARE ADJACENT TO THE INDICATED CAVITIES, BUT LOCATION AND ORIENTATION MAY DIFFER FROM PRINT.
- DIMENSIONS IN BRACKETS ARE IN INCHES.
- CONTACT IS PLATED OVERALL WITH 0.00127 [.000050] NICKEL, THEN 0.00076 [.000030] GOLD OVER CONTACT LENGTH INDICATED AND MATTE TIN ON SOLDER TAIL END.
- OBsolete PARTS: OBSOLETE CIS STREAMLINING PER D.RENAUD/D.SINISI

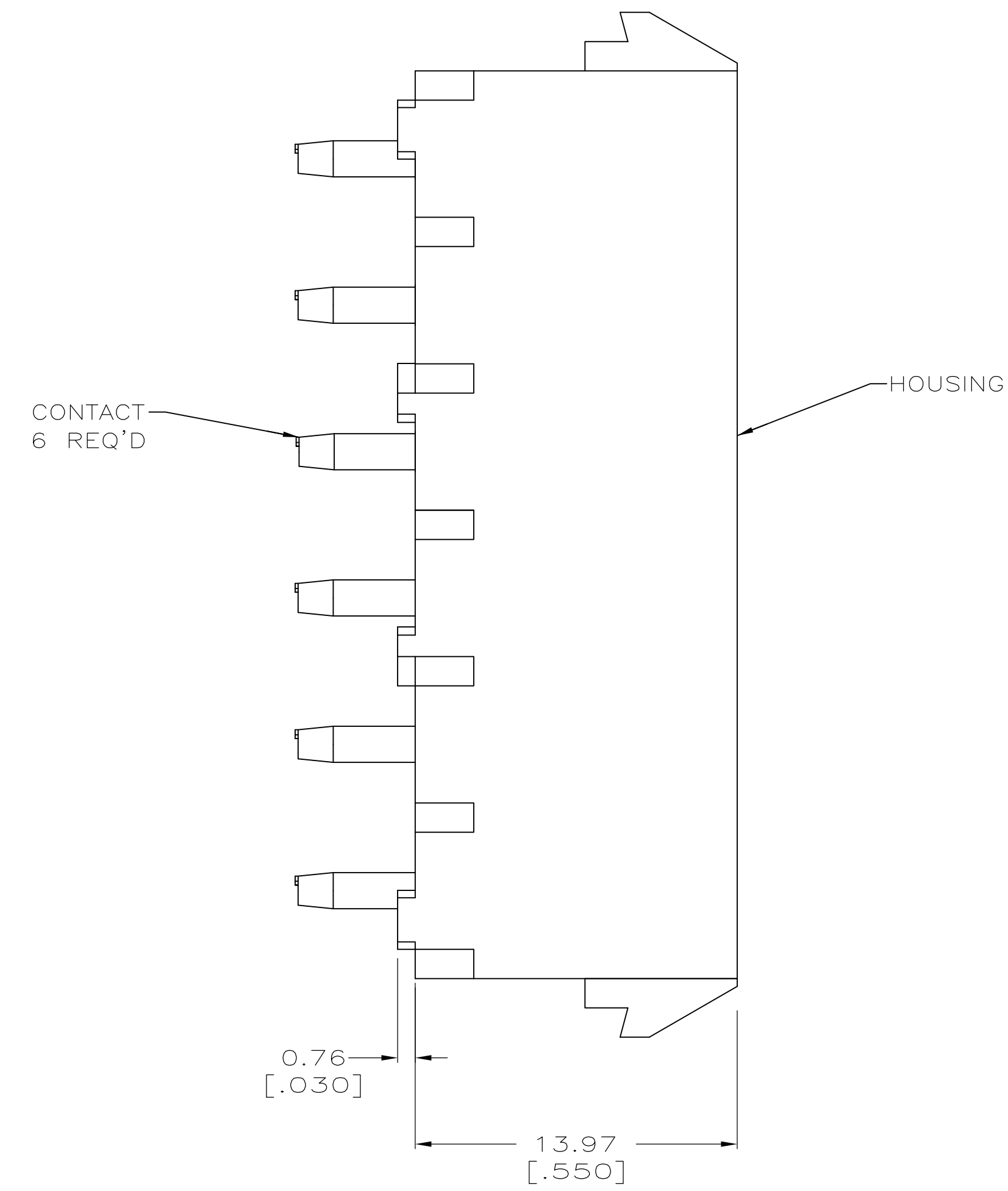
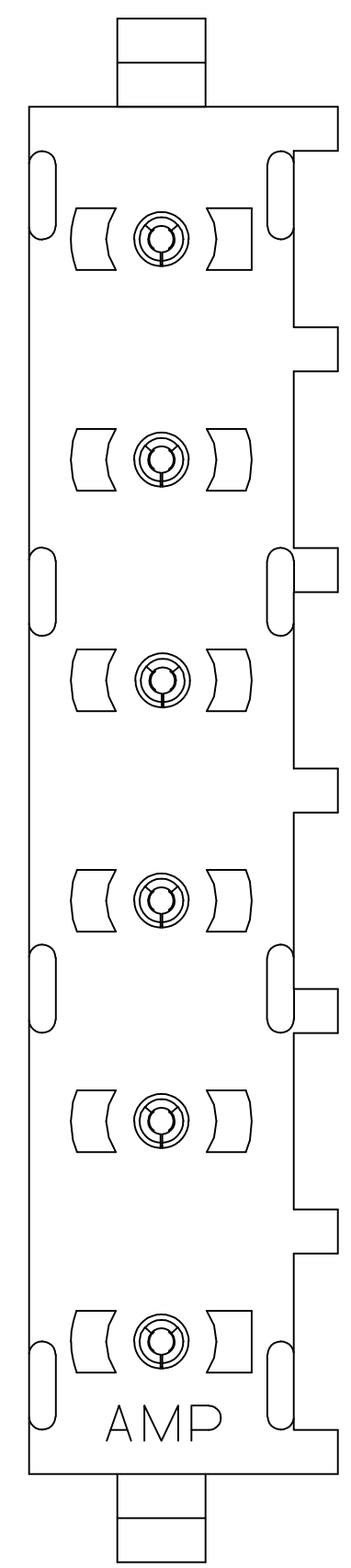
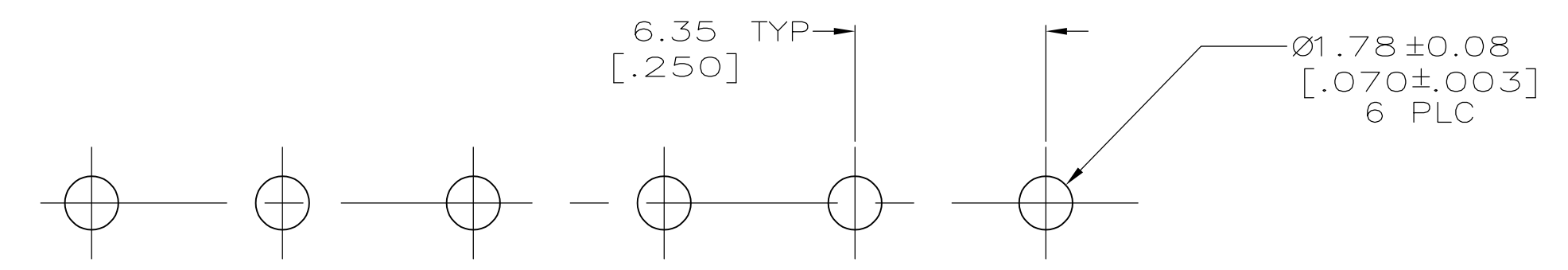
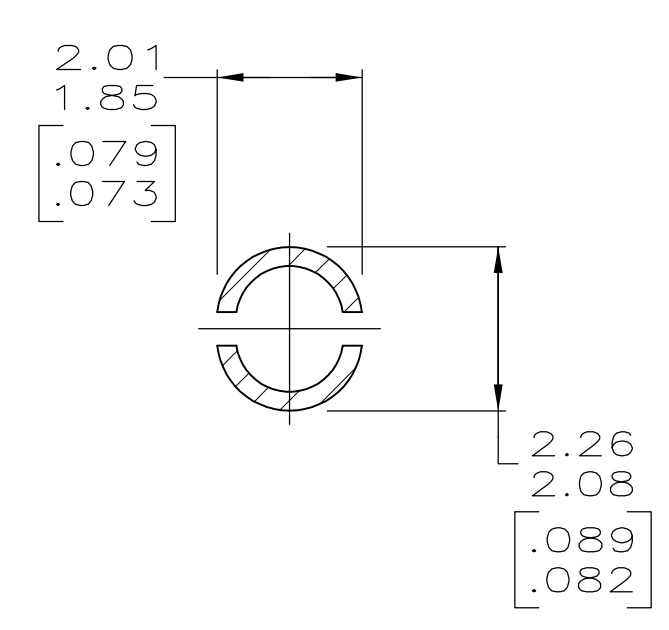
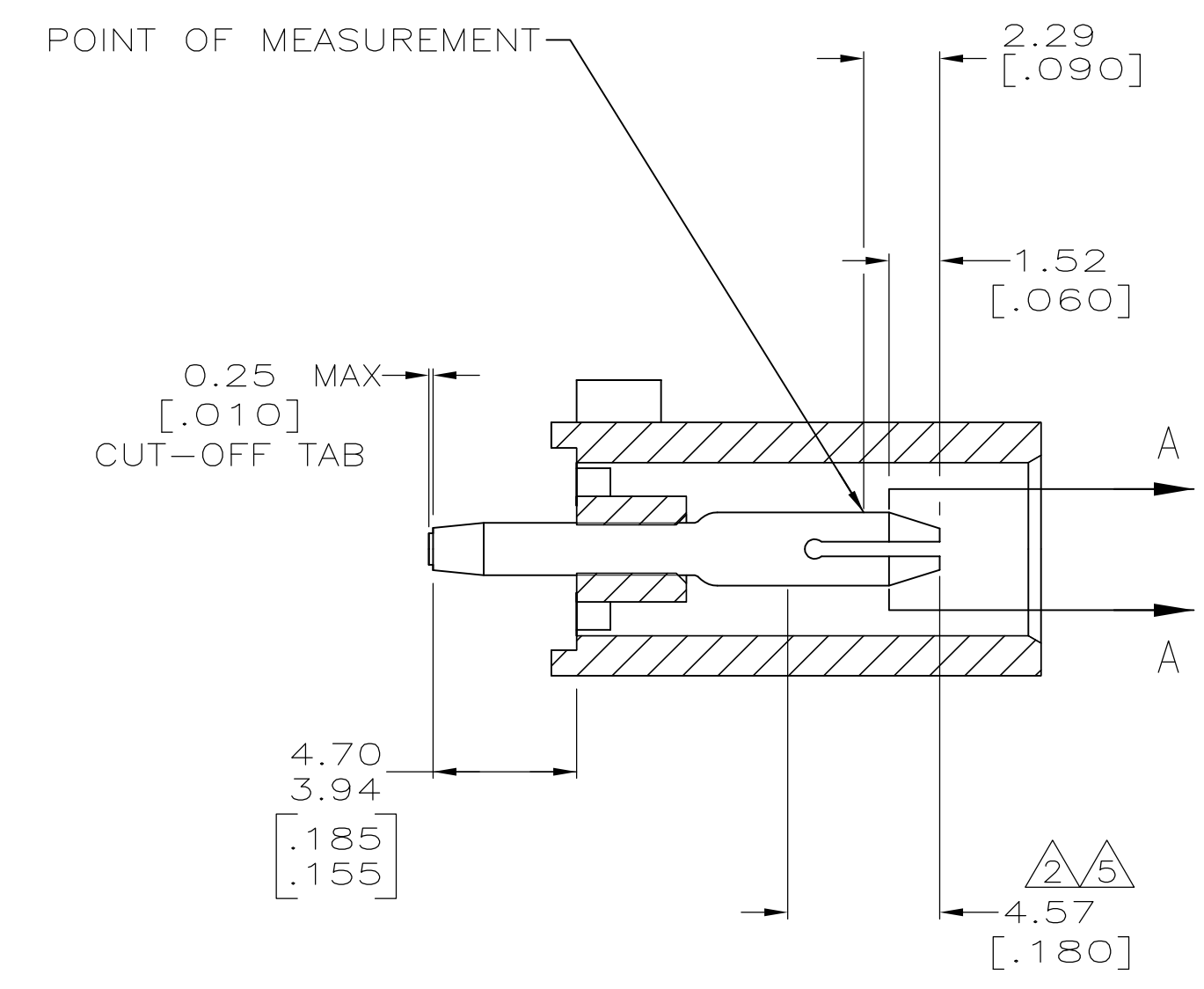
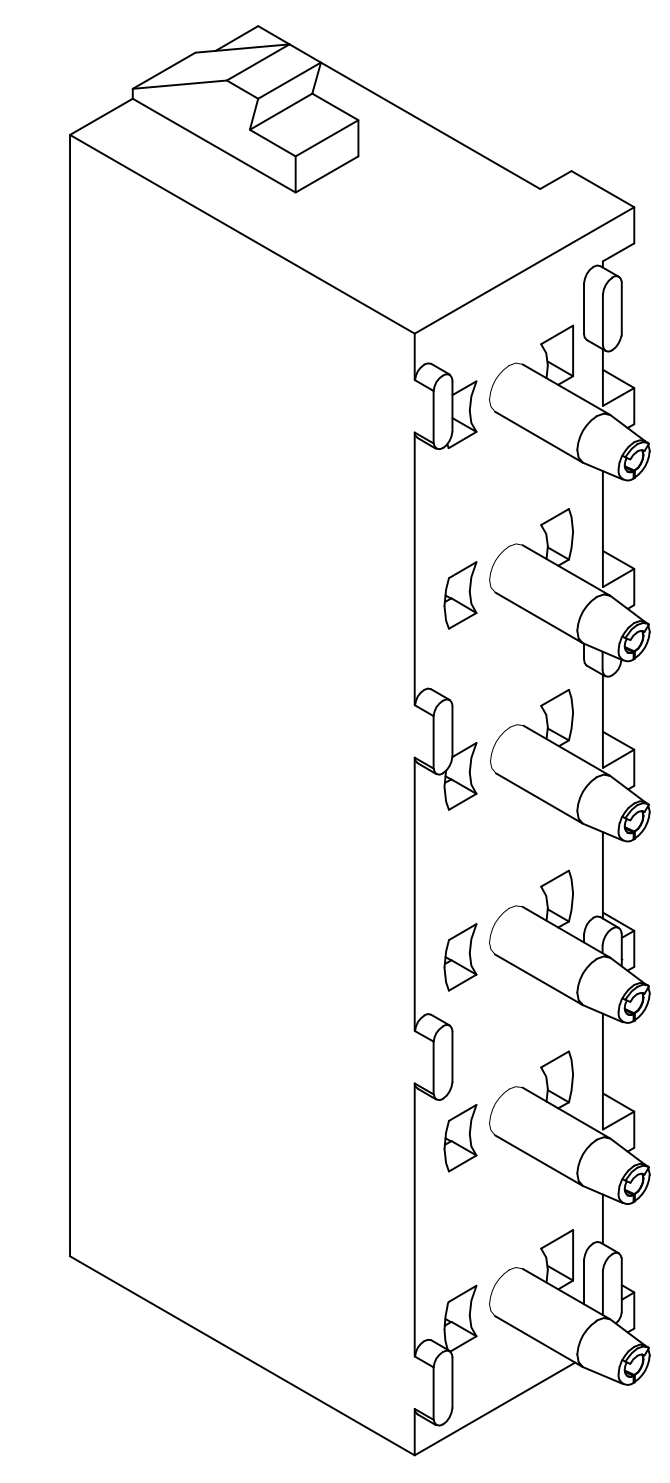

6	OBsolete	PHOSPHOR BRONZE, GOLD	NYLON,UL94V-2,NATURAL	-641832-3-
		PHOSPHOR BRONZE, GOLD	NYLON,UL94V-2,NATURAL	-641832-2-
		PHOSPHOR BRONZE, PRE-TIN	NYLON,UL94V-2,NATURAL	641832-1
		PIN CONTACT MATERIAL AND FINISH	HOUSING MATERIAL	PART NUMBER

METRIC

THIS DRAWING IS A CONTROLLED DOCUMENT.

DIMENSIONS: mm [INCHES]	TOLERANCES UNLESS OTHERWISE SPECIFIED:	DIN B LEWIS 10-05-98	APVD M TRULL 10-05-98	NAME	Tyco Electronics Corporation Greensboro, NC 27409
0 PLC ± -	1 PLC ± -	2 PLC ± 0.13 [0.005] [0.001]	3 PLC ± -	4 PLC ± -	ANGLES ± - 0° 30'
MATERIAL SEE TABLE	FINISH SEE TABLE	WEIGHT -	SIZE A1	CAGE CODE 00779	DRAWING NO. 641832
CUSTOMER DRAWING			SCALE 5:1	SHEET 1 OF 1	REV L1