

THIS DRAWING IS UNPUBLISHED. RELEASED FOR PUBLICATION
 © COPYRIGHT - By - ALL RIGHTS RESERVED.

LOC		DIST		REVISIONS			
P	LTR	DESCRIPTION		DATE	DWN	APVD	
AD	00	V2	REVISED PER ECO-11-004587	11MAR11	RK	HMR	

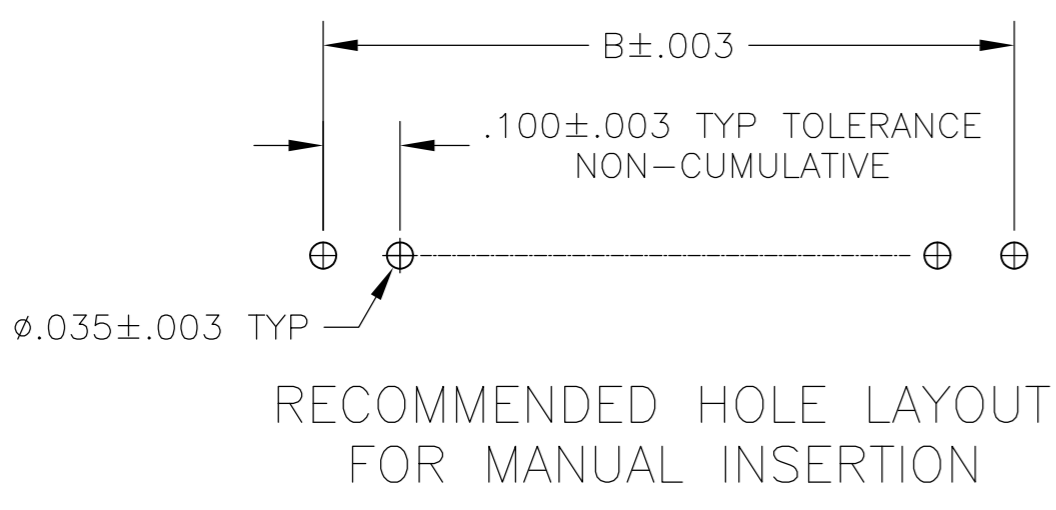
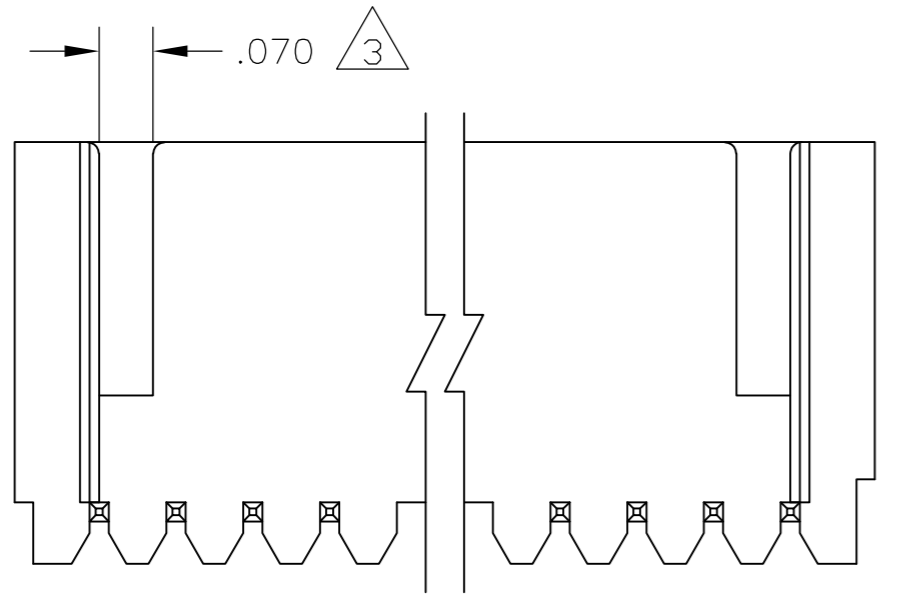
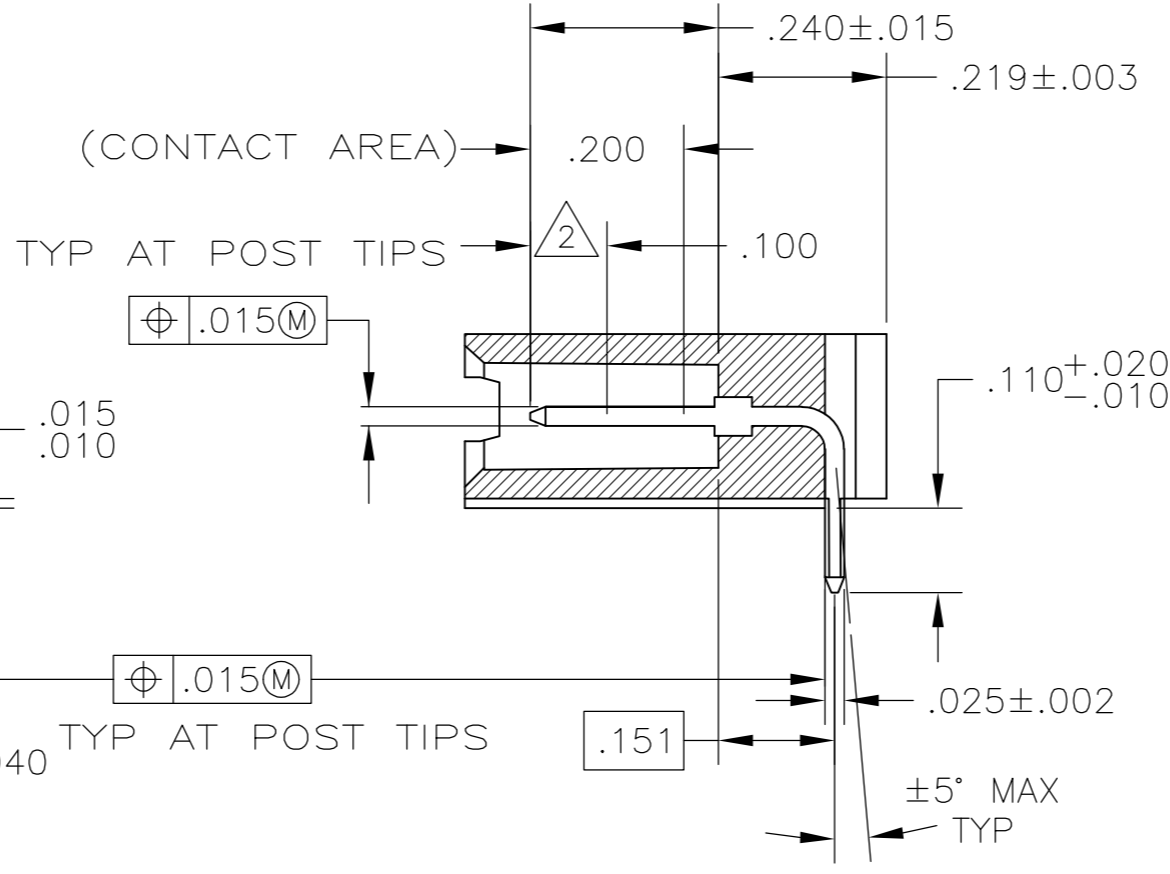
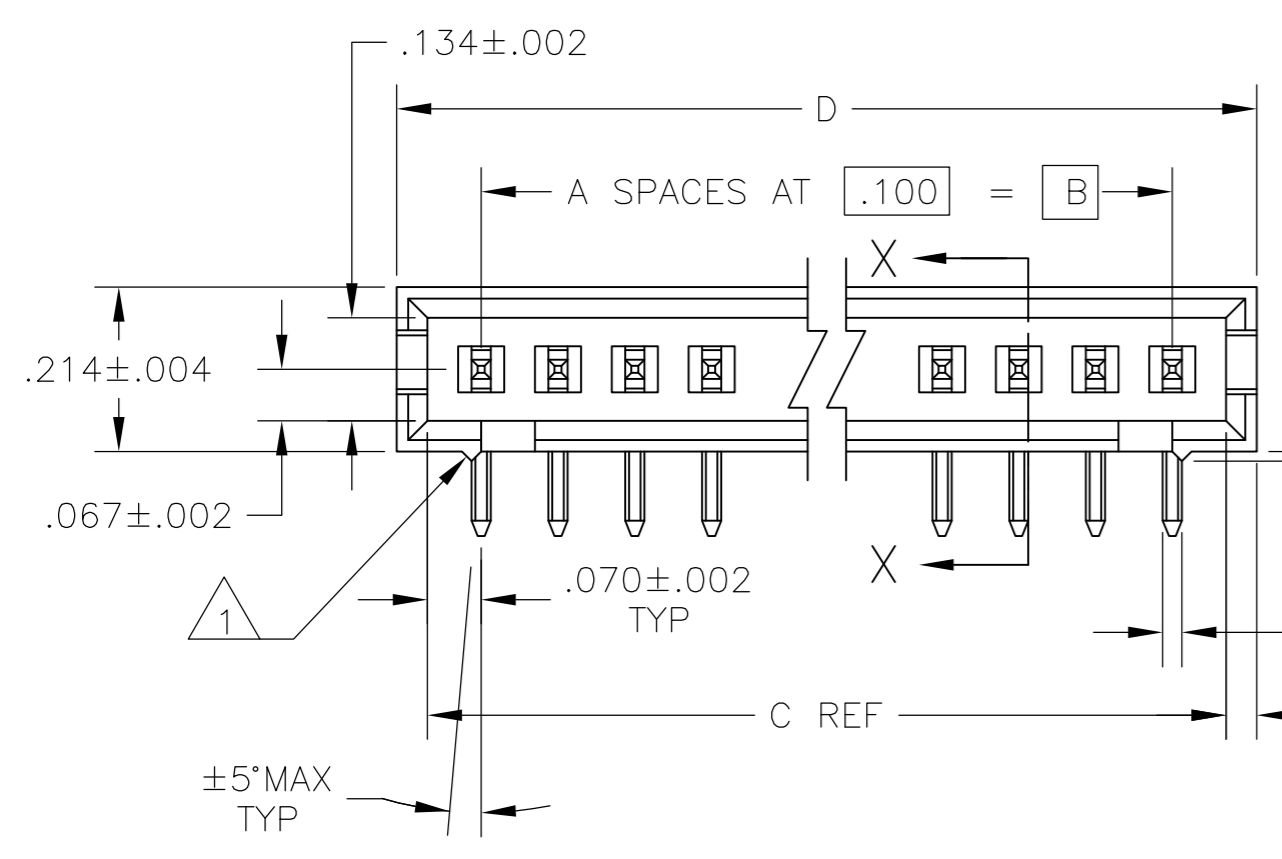
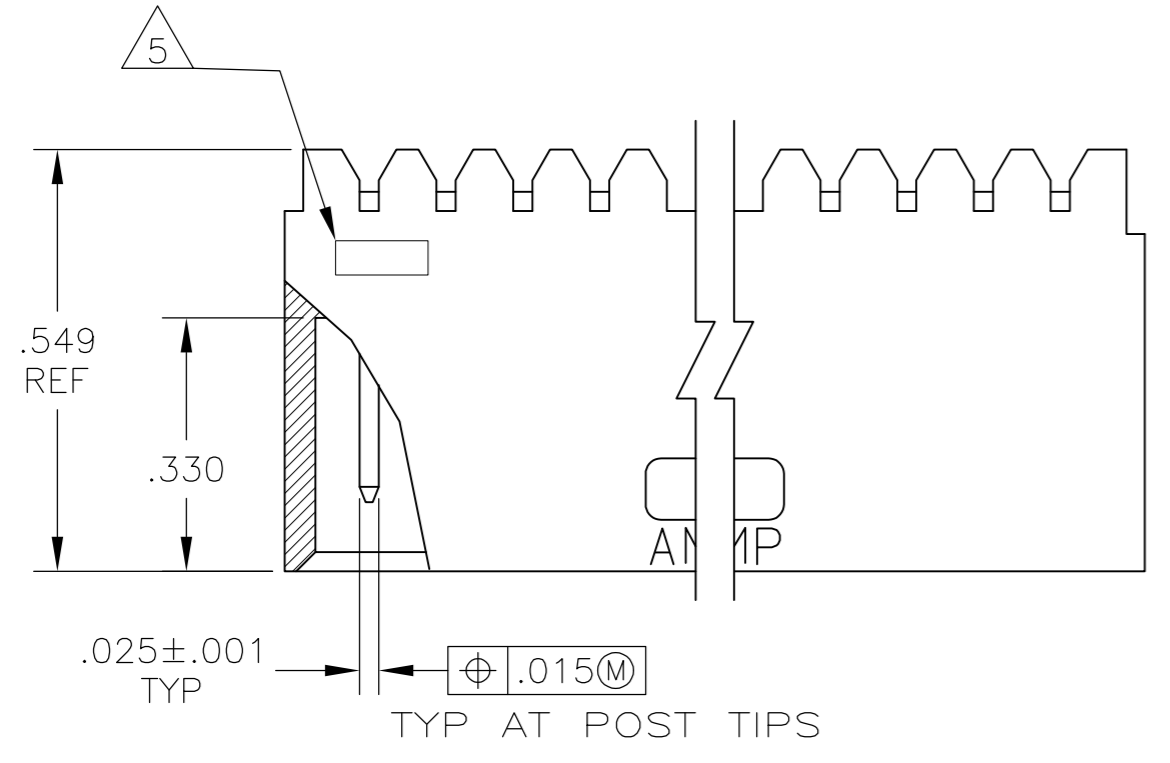

- 1 STANDOFFS: UP TO 9 POS-(2 REQD) ON THE OUTSIDE ENDS OF THE HOUSING 10 TO 19 POS-(3 REQD) TWO ON THE OUTSIDE ENDS AND ONE CENTERED ON THE HOUSING. 19 POS AND LARGER-(4 REQD) TWO ON THE OUTSIDE ENDS AND TWO SPACED EVENLY WITHIN THE REMAINING LENGTH OF THE HOUSING.
- 2 POINT OF MEASUREMENT FOR PLATING THICKNESS.
- 3 FOR 3 POS (3--4 & 3--9 ONLY) ONE SLOT, .215 WIDE.
- 4 INDICATED PARTS ARE PACKAGED IN "GANG-OF-TUBES".
- 5 RECESSED DATE CODE
- 6 INDICATED PARTS ARE PACKAGED IN "SINGLE TUBES".
- 7 .000015 GOLD ON THE CONTACT AREA, .000100-.000200 MATTE TIN-LEAD ON THE SOLDERTAIL, ALL OVER .000050 NICKEL.
- 8 .000015 GOLD ON THE CONTACT AREA, .000100-.000200 MATTE TIN ON THE SOLDERTAIL, ALL OVER .000050 NICKEL.
- 9 PRELIMINARY PART
- 10 OBSOLETE PARTS: OBSOLETE CIS STREAMLINING PER D.RENAUD/D.SINISI

THIS DRAWING IS A CONTROLLED DOCUMENT.		DWN	11JUN85	STE TE Connectivity
DIMENSIONS: INCHES		CHK	11JUN85	
TOLERANCES UNLESS OTHERWISE SPECIFIED:		NAME		
0 PLC ± -	ASSEMBLY, MOD II,HEADER,SINGLE ROW			
1 PLC ± -	.100 C/L, RIGHT ANGLE,WITH .025 SQ POST			
2 PLC ± -	SIZE CAGE CODE DRAWING NO RESTRICTED TO			
3 PLC ± .005	A2 00779 C=102203			
4 PLC ± -	SCALE 4:1 SHEET 1 of 2 REV V2			
ANGLES ± -	CUSTOMER DRAWING			
MATERIAL RETARDANT THERMOPLASTIC. COLOR-BLACK POSTS-PHOS BRONZE	FINISH SEE TABLE			

THIS DRAWING IS UNPUBLISHED. RELEASED FOR PUBLICATION
 © COPYRIGHT - By - ALL RIGHTS RESERVED.

LOC		DIST		REVISIONS				
P	LTR	DESCRIPTION			DATE	DWN	APVD	
-	-	SEE SHEET 1			-	-	-	

8	.820	.740	.600	6	7	8-102203-6	OBSOLETE
8	.420	.340	.200	2	3	8-102203-4	
8	2.620	2.540	2.400	24	25	7-102203-2	OBSOLETE
8	2.520	2.440	2.300	23	24	7-102203-1	OBSOLETE
8	2.420	2.340	2.200	22	23	7-102203-0	OBSOLETE
8	2.320	2.240	2.100	21	22	6-102203-9	
8	2.220	2.140	2.000	20	21	6-102203-8	OBSOLETE
8	2.120	2.040	1.900	19	20	6-102203-7	
8	2.020	1.940	1.800	18	19	6-102203-6	OBSOLETE
8	1.920	1.840	1.700	17	18	6-102203-5	
8	1.820	1.740	1.600	16	17	6-102203-4	OBSOLETE
8	1.720	1.640	1.500	15	16	6-102203-3	
8	1.620	1.540	1.400	14	15	6-102203-2	
8	1.520	1.440	1.300	13	14	6-102203-1	
8	1.420	1.340	1.200	12	13	6-102203-0	
8	1.320	1.240	1.100	11	12	5-102203-9	
8	1.220	1.140	1.000	10	11	5-102203-8	
8	1.120	1.040	.900	9	10	5-102203-7	
8	1.020	.940	.800	8	9	5-102203-6	OBSOLETE
8	.920	.840	.700	7	8	5-102203-5	
8	.820	.740	.600	6	7	5-102203-4	
8	.720	.640	.500	5	6	5-102203-3	
8	.620	.540	.400	4	5	5-102203-2	
8	.520	.440	.300	3	4	5-102203-1	
PLATING	D	C	B	A	NO OF POS	ASSEMBLY PART NUMBER	

9	8	1.720	1.640	1.500	15	16	4-102203-0
	8	.420	.340	.200	2	3	3-102203-9
9	8	1.020	.940	.800	8	9	3-102203-8
	8	.520	.440	.300	3	4	3-102203-7
6	10	OBSOLETE					
	7	.820	.740	.600	6	7	3-102203-6
SUPERSEDED BY 103361-8							
	7	1.120	1.040	.900	9	10	3-102203-5
	7	.420	.340	.200	2	3	3-102203-4
OBSOLETE	7	3.720	3.640	3.500	35	36	3-102203-3
OBSOLETE	7	3.620	3.540	3.400	34	35	3-102203-2
OBSOLETE	7	3.520	3.440	3.300	33	34	3-102203-1
OBSOLETE	7	3.420	3.340	3.200	32	33	3-102203-0
OBSOLETE	7	3.320	3.240	3.100	31	32	2-102203-9
OBSOLETE	7	3.220	3.140	3.000	30	31	2-102203-8
OBSOLETE	7	3.120	3.040	2.900	29	30	2-102203-7
OBSOLETE	7	3.020	2.940	2.800	28	29	2-102203-6
OBSOLETE	7	2.920	2.840	2.700	27	28	2-102203-5
OBSOLETE	7	2.820	2.740	2.600	26	27	2-102203-4
OBSOLETE	7	2.720	2.640	2.500	25	26	2-102203-3
10	7	2.620	2.540	2.400	24	25	2-102203-2
	7	2.520	2.440	2.300	23	24	2-102203-1
10	7	2.420	2.340	2.200	22	23	2-102203-0
	7	2.320	2.240	2.100	21	22	1-102203-9
10	7	2.220	2.140	2.000	20	21	1-102203-8
	7	2.120	2.040	1.900	19	20	1-102203-7
10	7	2.020	1.940	1.800	18	19	1-102203-6
	7	1.920	1.840	1.700	17	18	1-102203-5
10	7	1.820	1.740	1.600	16	17	1-102203-4
	7	1.720	1.640	1.500	15	16	1-102203-3
	7	1.620	1.540	1.400	14	15	1-102203-2
	7	1.520	1.440	1.300	13	14	1-102203-1
	7	1.420	1.340	1.200	12	13	1-102203-0
	7	1.320	1.240	1.100	11	12	102203-9
	7	1.220	1.140	1.000	10	11	102203-8
	7	1.120	1.040	.900	9	10	102203-7
	7	1.020	.940	.800	8	9	102203-6
	7	.920	.840	.700	7	8	102203-5
	7	.820	.740	.600	6	7	102203-4
	7	.720	.640	.500	5	6	102203-3
	7	.620	.540	.400	4	5	102203-2
	7	.520	.440	.300	3	4	102203-1
FINISH	D	C	B	A	NO OF POS	ASSEMBLY PART NUMBER	

THIS DRAWING IS A CONTROLLED DOCUMENT.

DWN	D.RINGLY	11JUN85
CHK	D.DUPLER	11JUN85
APVD	-	-
PRODUCT SPEC	-	
APPLICATION SPEC	-	
WEIGHT	-	-
CUSTOMER DRAWING	-	

STE TE Connectivity

ASSEMBLY, MOD II, HEADER, SINGLE ROW
 .100 C/L, RIGHT ANGLE, WITH .025 SQ POST

SIZE: A2 CAGE CODE: 00779 DRAWING NO: C=102203 RESTRICTED TO: -

SCALE: 1:1 SHEET: 2 OF 2 REV: V2