

## HD63B09, HD63C09

## CMOS MPU (Micro Processing Unit)

February 1987



## Description

The HD6309 is the highest 8-bit microprocessor of HMCS6800 family, which is compatible with the conventional HD6809.

The HD6309 has hardware and software features which make it an ideal processor for higher level language execution or standard controller applications.

The HD6309 is complete CMOS device and its power dissipation is extremely low. Moreover, the SYNC and CWAI instruction makes low power application possible.

## Features

- Hardware
  - Interfaces with all HMCS6800 peripherals
  - DMA transfer with no auto-refresh cycle
- Software: object code compatible with the HD6809
- Low power consumption mode (Sleep mode)
  - SYNC state of SYNC Instruction
  - WAIT state of CWAI Instruction
- On chip oscillator
- Wide operation range:  $f = 0.5$  to  $3$  MHz ( $V_{CC} = 5$  V  $\pm 10\%$ )

## Type of Products

Type No.	Bus Timing
HD63B09	2.0 MHz
HD63C09	3.0 MHz

## Pin Arrangement

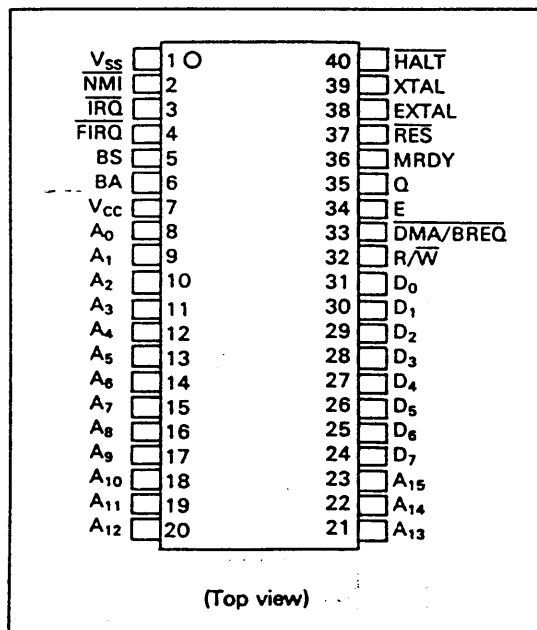

Block Diagram

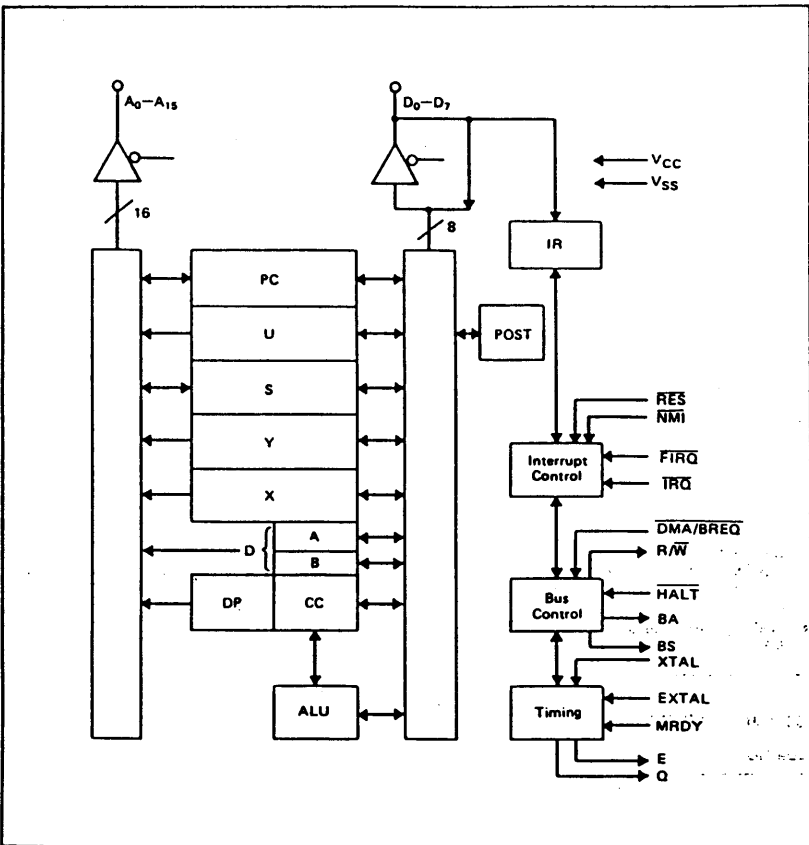

## Programming Model

As shown in figure 1, the HD6309 adds three registers to the set available in the HD6800. The added registers are a direct page register, the user stack pointer and a second index register.

### Accumulators (A, B, D)

The A and B registers are general purpose accumulators which are used for arithmetic calculations and manipulation of data.

Certain instructions concatenate the A and B registers to form a single 16-bit accumulator. This is referred to as the D register. It is formed with the A register as the most significant byte.

### Direct Page Register (DP)

The direct page register of the HD6309 serves to enhance the direct addressing mode. The contents of this register appears at the higher address outputs ( $A_{14} - A_{13}$ ) during direct addressing instruction execution. This allows the direct mode to be used at any place in memory, under program control. To ensure HD6800 compatibility, all bits of this register are cleared during processor reset.

### Index Registers (X, Y)

The index registers are used in indexed mode addressing. The 16-bit address in this register takes

part in the calculation of effective addresses. This address may be used to point to data directly or may be modified by an optional constant or register offset. In some indexed modes, the contents of the index register are incremented or decremented to point to the next item of tabular data. All four pointer registers (X, Y, U, S) may be used as index registers.

### Stack Pointer (U, S)

The hardware stack pointer (S) is used automatically by the processor during subroutine calls and interrupts. The stack pointers of the HD6309 point to the top of the stack, in contrast to the HD6800 stack pointer, which pointed to the next free location on the stack. The user stack pointer (U) is controlled exclusively by the programmer thus allowing arguments to be passed to and from subroutines with ease. Both stack pointers have the same indexed mode addressing capabilities as the X and Y registers, but also support push and pull instructions. This allows the HD6309 to be used efficiently as a stack processor, greatly enhancing its ability to support higher level languages and modular programming.

Note: The stack pointers of the HD6309 point to the top of the stack, in contrast to the HD6800 stack pointer, which pointed to the next free location on stack.

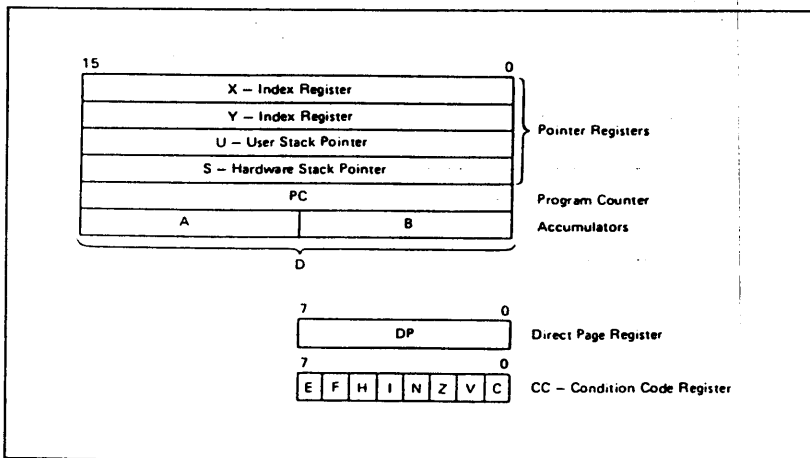

Figure 1. Programming Model of The Microprocessing Unit

**Program Counter (PC)**

The program counter is used by the processor to point to the address of the next instruction to be executed by the processor. Relative addressing is provided allowing the program counter to be used

like an index register in some situations.

**Condition Code Register (CC)**

The condition code register defines the state of the processor at any given time. See figure 2.

---

**Condition Code Register Description****Bit 0 (C)**

Bit 0 is the carry flag. It is usually the carry from the binary ALU. C is also used to represent a 'borrow' from subtract-like instructions (CMP, NEG, SUB, SBC). Then, it is the complement of the carry from the binary ALU.

recognize interrupts from the  $\overline{\text{IRQ}}$  line if this bit is set to one. NMI,  $\overline{\text{FIRQ}}$ ,  $\overline{\text{IRQ}}$ , RES, and SW1 all set I to one; SWI2 and SWI3 do not affect I.

**Bit 1 (V)**

Bit 1 is the overflow flag. It is set to a one by an operation which causes a signed two's complement arithmetic overflow. This overflow is detected in an operation in which the carry from the MSB in the ALU does not match the carry from the MSB minus 1.

**Bit 5 (H)**

Bit 5 is the half-carry bit. It is used to indicate a carry from bit 3 in the ALU as a result of an 8-bit addition only (ADC or ADD). This bit is used by the DAA instruction to perform a BCD decimal add adjust operation. The state of this flag is undefined in all subtract-like instructions.

**Bit 2 (Z)**

Bit 2 is the zero flag. It is set to one if the result of the previous operation was identically zero.

**Bit 6 (F)**

Bit 6 is the  $\overline{\text{FIRQ}}$  mask bit. The processor will not recognize interrupts from the  $\overline{\text{FIRQ}}$  line if this bit is a one. NMI,  $\overline{\text{FIRQ}}$ , SWI, and RES all set F to one.  $\overline{\text{IRQ}}$ , SWI2 and SWI3 do not affect F.

**Bit 3 (N)**

Bit 3 is the negative flag. It contains exactly the value of the MSB of the result of the preceding operation. Thus, a negative two's-complement result will leave N set to one.

**Bit 7 (E)**

Bit 7 is the entire flag. Set to one, it indicates that the complete machine state (all the registers) was stacked, as opposed to the subset state (PC and CC). The E bit of the stacked CC is used on a return from interrupt (RTI) to determine the extent of the unstacking. Therefore, the current E left in the condition code register represents past action.

**Bit 4 (I)**

Bit 4 is the  $\overline{\text{IRQ}}$  mask bit. The processor will not

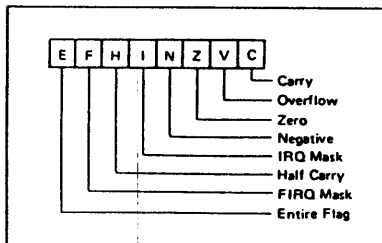

Figure 2. Condition Code Register Format

## Signal Description

### Power ( $V_{SS}$ , $V_{CC}$ )

Two pins supply power to the part:  $V_{SS}$  is ground or 0 volts, while  $V_{CC}$  is  $+5.0\text{ V} \pm 10\%$ .

### Address Bus ( $A_0 - A_{15}$ )

Sixteen pins output address information from the MPU onto the address bus. When the processor does not require the bus for a data transfer, it will output address  $FFFF_{16}$ ,  $R/\overline{W}$ =high, and  $BS$ =low. This is a "dummy access" or  $\overline{VMA}$  cycle (see figures 25 and 26). All address bus drivers are made high impedance when the bus available output ( $BA$ ) is high. Each pin will drive one Schottky TTL load or four LS TTL loads, and typically 90 pF.

### Data Bus ( $D_0 - D_7$ )

These eight pins provide communication with the system bi-directional data bus. Each pin will drive one Schottky TTL load or four LS TTL loads, and typically 130 pF.

### Read/Write ( $R/\overline{W}$ )

This signal indicates the direction of data transfer on the data bus. A low indicates that the MPU is writing data onto the data bus.  $R/\overline{W}$  is made high impedance when  $BA$  is high. Refer to figures 25 and 26.

### Reset ( $\overline{RES}$ )

A low level on this Schmitt-trigger input for greater than one bus cycle will reset the MPU, as shown in figure 3. The reset vectors are fetched from locations  $FFE_{16}$  and  $FFF_{16}$  (table 2) when interrupt acknowledge is true. ( $\overline{BA} \cdot BS=1$ ). During initial power-on, the reset line should be held low until the clock oscillator is fully operational. See figure 4.

Because the HD6309 reset pin has a Schmitt-trigger input with a threshold voltage higher than that of standard peripherals, a simple R/C network may be used to reset the entire system. This higher

Table 1. Pin Description

Symbol	Pin No.	I/O	Function
$V_{SS}$	1		Ground
$\overline{NMI}$	2	I	Non maskable interrupt
$\overline{IRQ}$	3	I	Interrupt request
$\overline{FIRQ}$	4	I	Fast interrupt request
$BS, BA$	5, 6	O	Bus status, Bus available
$V_{CC}$	7		+5 V power supply
$A_0 - A_{15}$	8-23	O	Address bus, bits 0-15
$D_7 - D_0$	24-31	I/O	Data bus, bits 0-7
$R/\overline{W}$	32	O	Read / Write output
$\overline{DMA/BREQ}$	33	I	DMA Bus request
$E, Q$	34, 35	O	Clock signal
$\overline{MRDY}$	36	I	Memory ready
$\overline{RES}$	37	I	Reset input
$\overline{EXTAL}, XTAL$	38, 39	I	Oscillator connection
$\overline{HALT}$	40	I	Halt input

threshold voltage ensures that all peripherals are out of the reset state before the processor.

**Halt (HALT)**

A low level on this input pin will cause the MPU to stop running at the end of the present instruction and remain halted indefinitely without loss of data. When halted, the BA output is driven high indicating the buses are high impedance. BS is also high which indicates the processor is in the halt or bus grant state. While halted, the MPU will not respond to external realtime requests (FIRQ, IRQ) although DMA/BREQ will always be accepted, and NMI or RES will be latched for later response. During the halt state, Q and E continue to run normally. If the MPU is not running (RES), a halted state (BA · BS = 1) can be achieved by pulling HALT low while RES is still low. See figure 5.

**Bus Available, Bus Status (BA, BS)**

The BA output is an indication of an internal control signal which makes the MOS buses of the MPU high impedance. This signal does not imply that the bus will be available for more than one cycle. When BA goes low, an additional dead cycle will elapse before the MPU acquires the bus.

The BS output signal, when decoded with BA, represents the MPU state.

Interrupt Acknowledge is indicated during both cycles of a hardware vector fetch (RES, NMI, FIRQ, IRQ, SW1, SW12, SW13). This signal, plus decoding of the lower four address lines, can provide the user with an indication of which interrupt level is being serviced and allow vectoring by device. See Table 2.

Sync Acknowledge is indicated while the MPU is waiting for external synchronization on an interrupt line.

Halt/Bus Grant is true when the HD6309 is in a halt or bus grant condition.

**Non Maskable Interrupt (NMI)**

A negative edge on NMI requests that a non-maskable interrupt sequence be generated. A non-maskable interrupt cannot be inhibited by the program, and also has a higher priority than FIRQ, IRQ or software interrupts. During recognition of an NMI, the entire machine state is saved on the hardware stack. After reset, an NMI will not be recognized until the first program load of the hardware stack pointer (S). The pulse width of NMI low must be at least one E cycle. If the NMI input does not meet the minimum set up with respect to Q, the interrupt will not be recognized until the next cycle. See figure 6.

**Table 2. Memory Map for Interrupt Vectors**

Memory Map for Vector Locations		Interrupt Vector Description
MS	LS	
FFFE	FFFF	RES
FFFC	FFFD	NMI
FFFA	FFFB	SW1
FFF8	FFF9	IRQ
FFF6	FFF7	FIRQ
FFF4	FFF5	SW12
FFF2	FFF3	SW13
FFF0	FFF1	Reserved

**Table 3. MPU State Definition**

BA	BS	MPU State
0	0	Normal (Running)
0	1	Interrupt or RESET Acknowledge
1	0	SYNC Acknowledge
1	1	HALT or Bus Grant

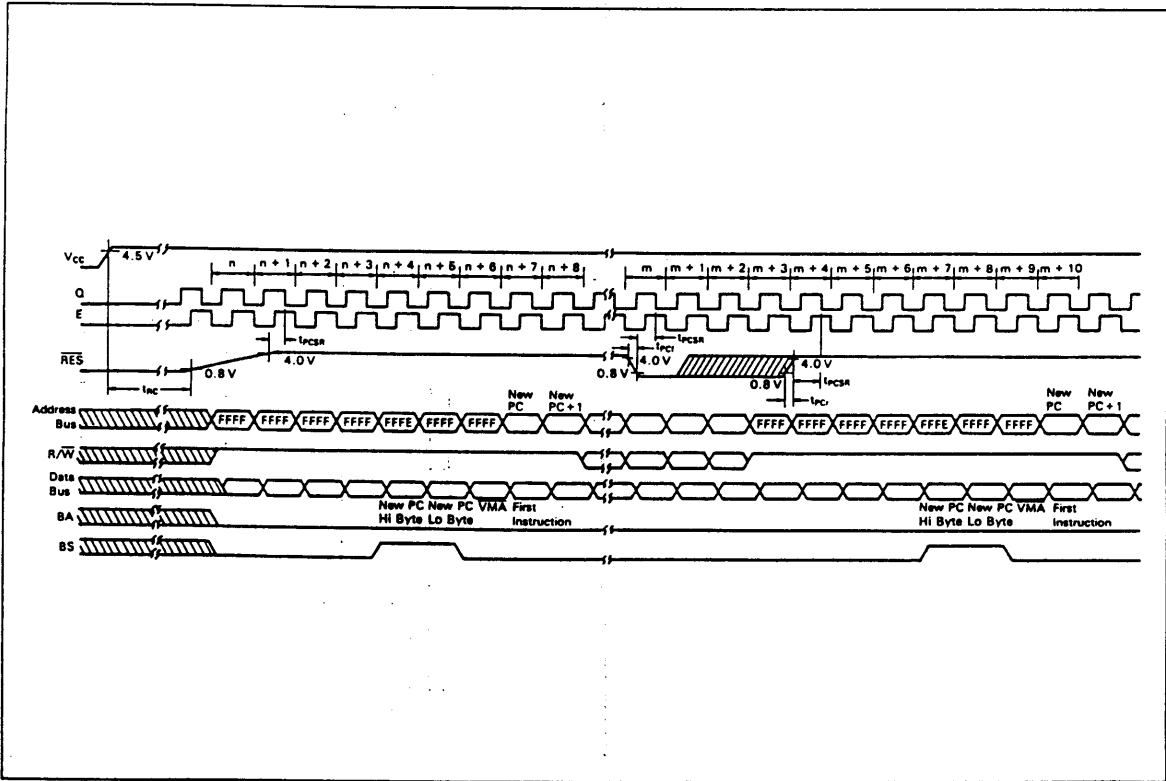

Figure 3. RES Timing

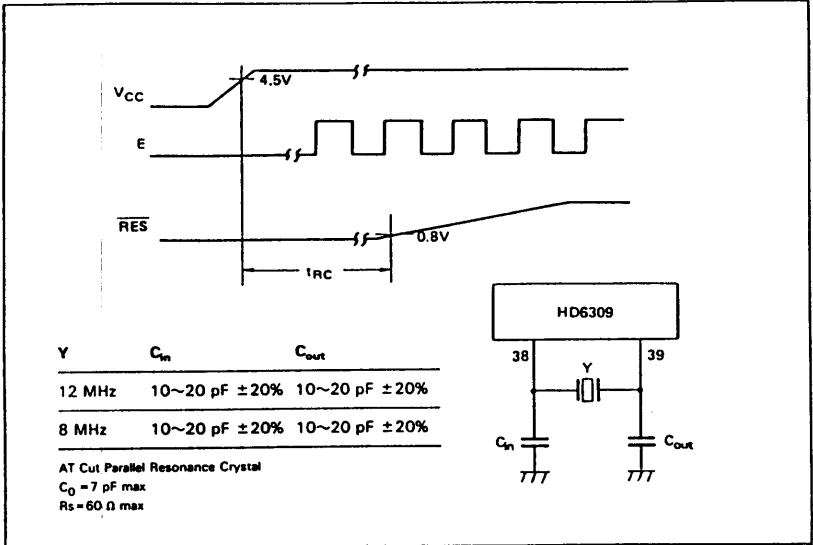

Figure 4. Crystal Connections and Oscillator Start Up

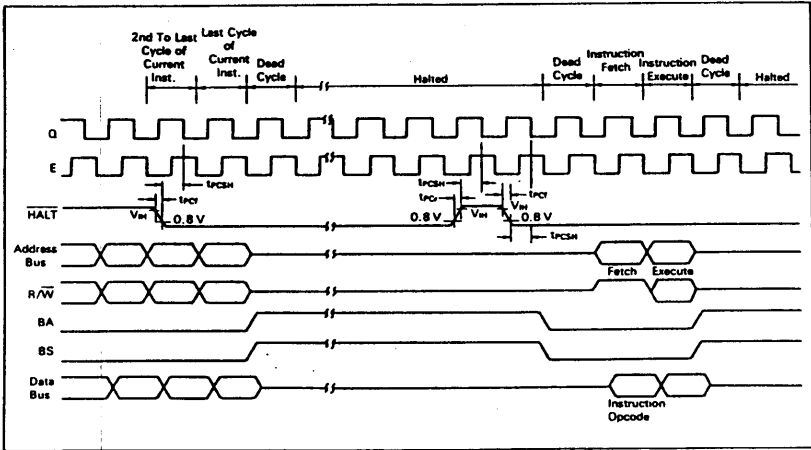

Figure 5. HALT and Single Instruction Execution for System Debug

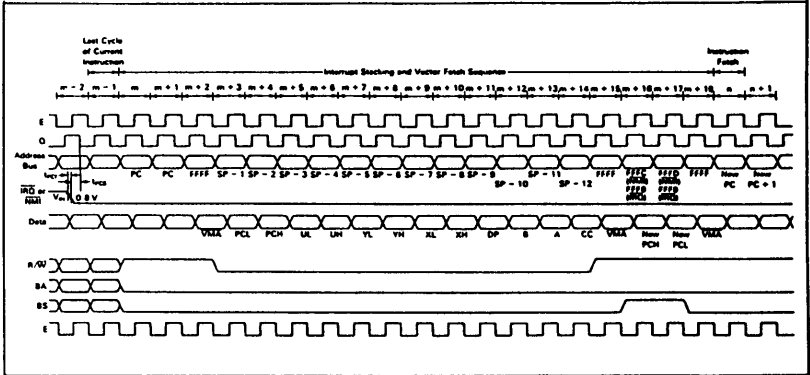

Figure 6. IRQ and NMI Interrupt Timing

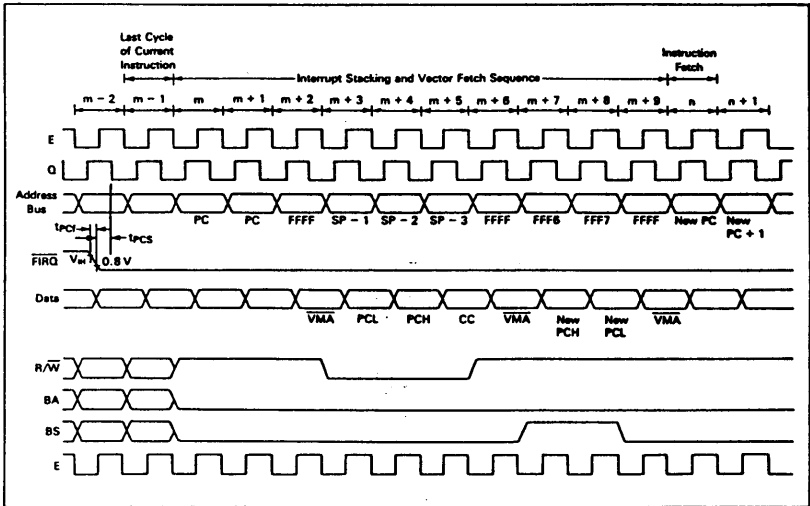

Figure 7. FIRQ Interrupt Timing

### Fast Interrupt Request ( $\overline{\text{FIRQ}}$ )

A low level on  $\overline{\text{FIRQ}}$  input will initiate a fast interrupt sequence provided its mask bit (F) in the CC is clear. This sequence has priority over the standard interrupt request ( $\overline{\text{IRQ}}$ ). It is fast in the sense that it stacks only the contents of the condition code register and the program counter. The interrupt service routine should clear the source of the interrupt before doing an RTI. See figure 7.

### Interrupt Request ( $\overline{\text{IRQ}}$ )

A low level input on  $\overline{\text{IRQ}}$  will initiate an interrupt request sequence provided the mask bit (I) in the CC is clear. Since  $\overline{\text{IRQ}}$  stacks the entire machine state it provides a slower response to interrupts than  $\overline{\text{FIRQ}}$ .  $\overline{\text{IRQ}}$  also has a lower priority than  $\overline{\text{FIRQ}}$ . Again, the interrupt service routine should clear the source of the interrupt before doing an RTI. See figure 6.

Note:  $\overline{\text{NMI}}$ ,  $\overline{\text{FIRQ}}$ , and  $\overline{\text{IRQ}}$  requests are sampled on the falling edge of Q. One cycle is required for synchronization before these interrupts are recognized. The pending interrupt(s) will not be serviced until completion of the current instruction unless a SYNC or CWA condition is present. If  $\overline{\text{FIRQ}}$  and  $\overline{\text{FIRQ}}$  do not remain low until completion of the current

instruction they may not be recognized. However,  $\overline{\text{NMI}}$  is latched and need only remain low for one cycle.

### XTAL, EXTAL

These two pins are connected with parallel resonant fundamental crystal, AT cut. Alternately, the pin EXTAL may be used as a TTL level input for external timing with XTAL floating. The crystal or external frequency is four times the bus frequency. See figure 4. Proper RF layout techniques should be observed in the layout of printed circuit boards.

Note for Board Design of the Oscillation Circuit: In designing the board, the following notes should be taken when the crystal oscillator is used. See figure 8.

1. Crystal oscillator and load capacity  $C_{in}$ ,  $C_{out}$  must be placed near the LSI as much as possible. (Normal oscillation may be disturbed when external noise is induced to pin 38 and 39.)
2. Pin 38 and 39 signal line should be wired apart from other signal line as much as possible. Don't wire them in parallel with other lines. (Normal oscillation may be disturbed when E or Q signal feeds back to pin 38 and 39.)

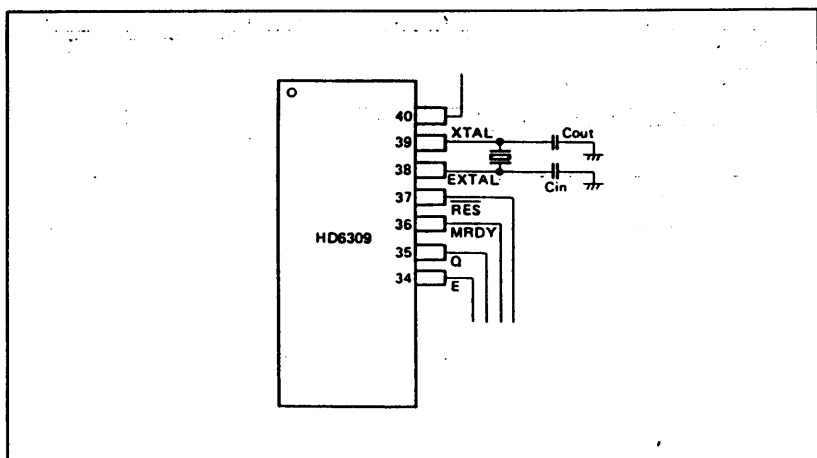

Figure 8. Board Design of the Oscillation Circuit

**Designs to be Avoided:** A signal line or a power source line must not cross or go near the oscillation circuit line as shown in figure 9 to prevent induction from these lines. The resistance between XTAL, EXTAL and other pins should be over 10 MΩ.

**E, Q**

E is similar to the HD6800 bus timing signal  $\phi_2$ : Q is a quadrature clock signal which leads E. Q has no parallel on the HD6800. Data is latched on the falling edge of E. Timing for E and Q is shown in figure 10.

**Memory Ready (MRDY)**

This input control signal allows stretching of E and Q to extend data-access time. E and Q operate normally while MRDY is high. When MRDY is low, E and Q may be stretched in integral multiples of half (1/2) bus cycles, thus allowing interface to slow memories, as shown in figure 11. The maximum stretch is 5 microseconds.

During nonvalid memory access ( $\overline{VMA}$  cycles) MRDY has no effect on stretching E and Q: this inhibits slowing the processor during "don't care"

bus accesses. MRDY may also be used to stretch clocks (for slow memory) when bus control has been transferred to an external device (through the use of HALT and DMA/BREQ).

MRDY also stretches E and Q during dead cycles.

**DMA Bus Request ( $\overline{DMA/BREQ}$ )**

The  $\overline{DMA/BREQ}$  input provides a method of suspending execution and acquiring the MPU bus for another use, as shown in figure 12. Typical uses include DMA and dynamic memory refresh.

Transition of  $\overline{DMA/BREQ}$  should occur during Q. A low level on this pin will stop instruction execution at the end of the current cycle. The MPU will acknowledge  $\overline{DMA/BREQ}$  by setting BA and BS to high level. The HD6309 does not perform the auto-refresh executed in the HD6809. See figure 13.

Typically, the DMA controller will request to use the bus by asserting  $\overline{DMA/BREQ}$  pin low on the leading edge of E. When the MPU replies by setting BA and BS to one, that cycle will be a dead cycle used to transfer bus mastership to the DMA controller.

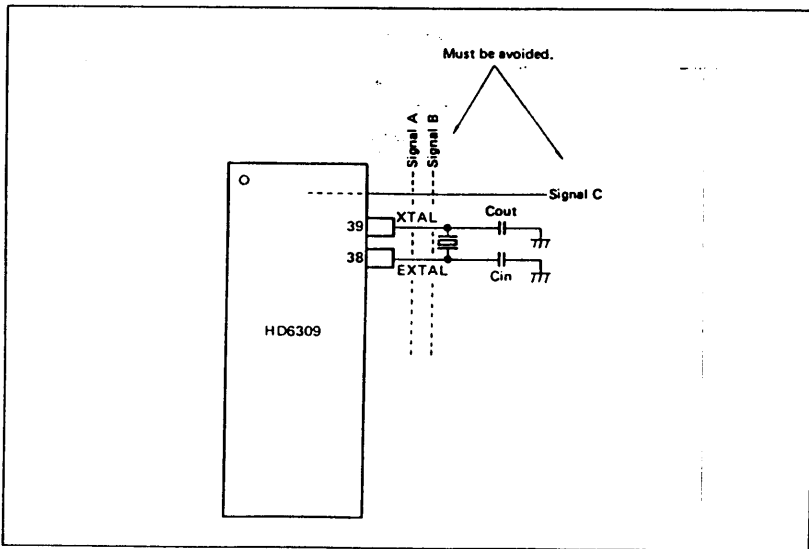

Figure 9. Example of Normal Oscillation may be Disturbed

False memory accesses may be prevented during dead cycles by developing a system  $\overline{\text{DMAVMA}}$  signal which is low in any cycle when BA has changed.

When BA goes low (a result of  $\overline{\text{DMA/BREQ}} =$

high), another dead cycle will elapse before the MPU accesses memory, to allow transfer of bus mastership without contention.

The  $\overline{\text{DMA/BREQ}}$  input should be tied high during reset state.

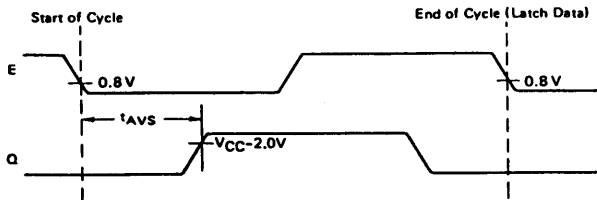

Figure 10. E/Q Relationship

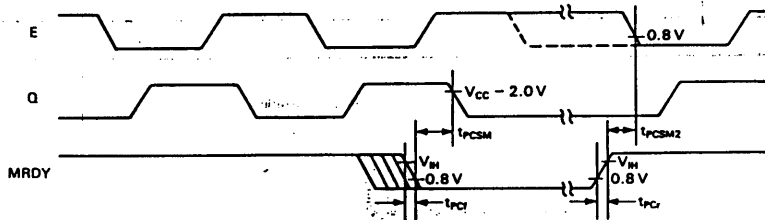

Figure 11. MRDY Clock Stretching



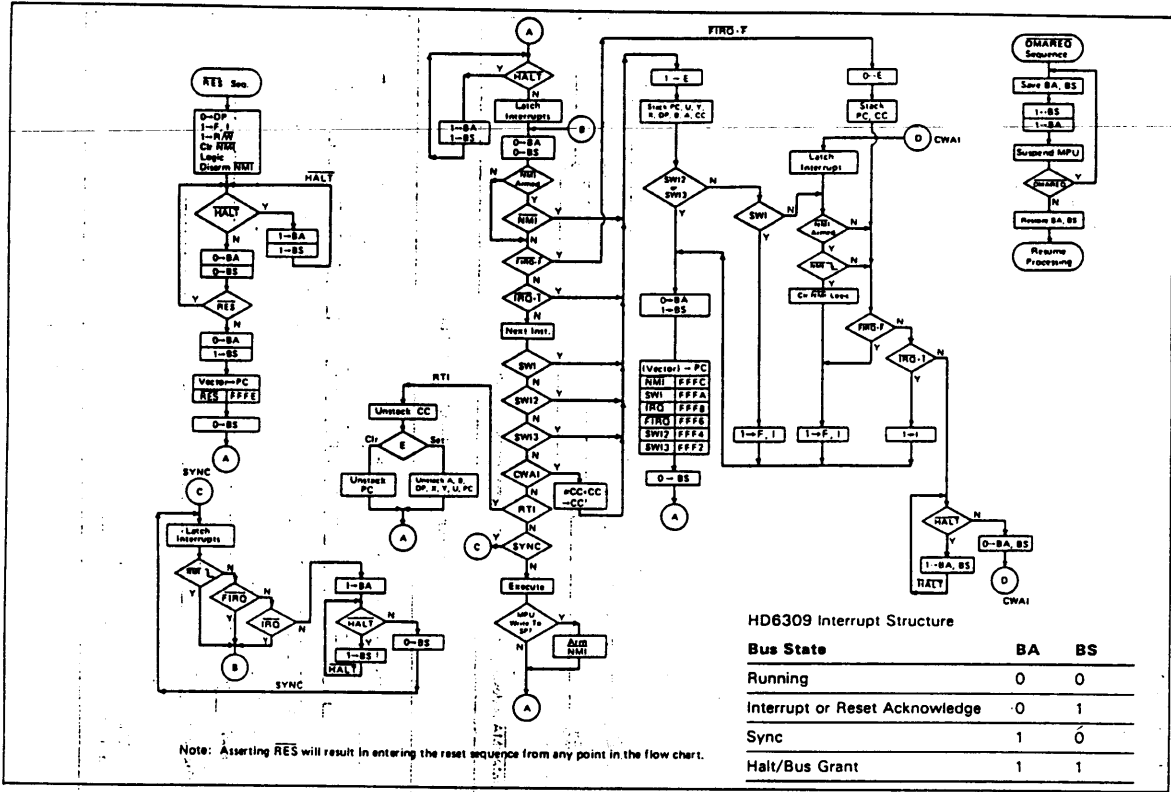

Figure 14. Flowchart for HD6309 Instruction

## Addressing Modes

The basic instructions of any computer are greatly enhanced by the presence of powerful addressing modes. The HD6309 has the most complete set of addressing modes available on any micro-computer today. For example, the HD6309 has 59 basic instructions, however, it recognizes 1464 different variations of instructions and addressing modes. The addressing modes support modern programming techniques. The following addressing modes are available on the HD6309:

- Implied (includes accumulator)
- Immediate
- Extended
- Extended indirect
- Direct
- Register
- Indexed
  - Zero-offset
  - Constant offset
  - Accumulator offset
  - Auto increment/decrement
- Indexed indirect
- Relative
- Program counter relative

### Implied (Includes Accumulator)

In this addressing mode, the opcode of the instruction contains all the address information necessary. Examples of implied addressing are: ABX, DAA, SWI, ASRA, and CLR B.

### Immediate Addressing

In immediate addressing, the effective address of the data is the location immediately following the opcode (i.e., the data to be used in the instruction immediately follows the opcode of the instruction). The HD6309 uses both 8- and 16-bit immediate values depending on the size of the argument specified by the opcode. Examples of instructions with immediate addressing are:

```
LDA #S20
LDX #SF000
LDY #CAT
```

Note: # signifies immediate addressing, \$ signifies hexadecimal value.

### Extended Addressing

In extended addressing, the contents of the two bytes immediately following the opcode fully specify the 16-bit effective address used by the instruction. Note that the address generated by an

extended instruction defines an absolute address and is not position independent. Examples of extended addressing include:

```
LDA CAT
STX MOUSE
LDD $2000
```

### Extended Indirect

As a special case of indexed addressing (discussed below), one level of indirection may be added to extended addressing. In extended indirect, the two bytes following the postbyte of an indexed instruction contain the address of the data.

```
LDA [CAT]
LDX [SFFFE]
STU [DOG]
```

### Direct Addressing

Direct addressing is similar to extended addressing except that only one byte of address follows the opcode. This byte specifies the lower 8 bits of the address to be used. The upper 8 bits of the address are supplied by the direct page register. Since only one byte of address is required in direct addressing, this mode requires less memory and executes faster than extended addressing. Of course, only 256 locations (one page) can be accessed without redefining the contents of the DP register. Since the DP register is set to \$00 on reset, direct addressing on the HD6309 is compatible with direct addressing on the HD6800. Indirection is not allowed in direct addressing. Some examples of direct addressing are:

```
LDA $30
SETDP $10 (Assembler directive)
LDB $1030
LDD <CAT
```

Note: < is an assembler directive which forces direct addressing.

### Register Addressing

Some opcodes are followed by a byte that defines a register or set of registers to be used by the instruction. This is called a postbyte. Some examples of register addressing are:

```
TFR X,Y      Transfers X into Y
EXG A,B      Exchanges A with B
PSHS A,B,X,Y Push Y, X, B, and A onto S
PULU X,Y,D   Pull D, X, and Y from U
```

**Indexed Addressing**

In all indexed addressing, one of the pointer registers (X, Y, U, S, and sometimes PC) is used in a calculation of the effective address of the operand to be used by the instruction. Five basic types of indexing are available and are discussed below. The postbyte of an indexed instruction specifies the basic type and variation of the addressing mode as well as the pointer register to be used. Figure 15 lists the legal formats for the postbyte. Table 4 gives the assembler form and the number of cycles

and bytes added to the basic values for indexed addressing for each variation.

**Zero-Offset Indexed:** In this mode, the selected pointer register contains the effective address of the data to be used by the instruction. This is the fastest indexing mode.

Examples are:

```
LDD 0, X
LDA S
```

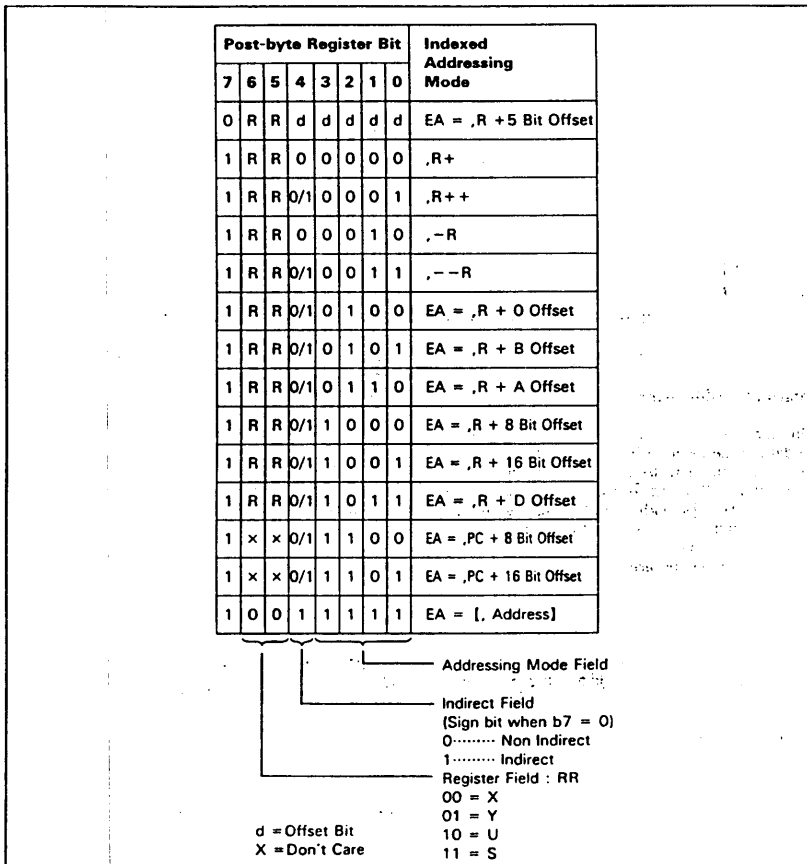

Figure 15. Indexed Addressing Postbyte Register Bit Assignments

**Constant Offset Indexed:** In this mode, a two's-complement offset and the contents of one of the pointer registers are added to form the effective address of the operand. The pointer register's initial content is unchanged by the addition.

the two bytes following the postbyte. In most cases the programmer need not be concerned with the size of this offset since the assembler will select the optimal size automatically.

Three sizes of offsets are available:

- 5-bit (-16 to +15)
- 8-bit (-128 to +127)
- 16-bit (-32768 to +32767)

Examples of constant-offset indexing are:

- LDA 23, X
- LDX -2, S
- LDY 300, X
- LDU CAT, Y

The two's complement 5-bit offset is included in the postbyte and, therefore, is most efficient in use of bytes and cycles. The two's complement 8-bit offset is contained in a single byte following the postbyte. The two's complement 16-bit offset is in

**Accumulator Offset Indexed:** This mode is similar to constant offset indexed except that the two's-complement value in one of the accumulators (A, B or D) and the contents of one of the pointer registers are added to form

Table 4. Indexed Addressing Mode

Type	Forms	Non Indirect		Indirect	
		Assembler Form	Postbyte OP Code	++ Assembler Form	Postbyte OP Code
Constant Offset From R (2's Complement Offsets)	No Offset	,R	1RR00100 0 0	[,R]	1RR10100 3 0
	5 Bit Offset	n,R	ORRnnnnn	1 0 defaults to 8-bit	
	8 Bit Offset	n,R	1RR01000 1 1	[n, R]	1RR11000 4 1
	16 Bit Offset	n,R	1RR01001 4 2	[n, R]	1RR11001 7 2
Accumulator Offset From R (2's Complement Offsets)	A Register Offset	A,R	1RR00110 1 0	[A, R]	1RR10110 4 0
	B Register Offset	B,R	1RR00101 1 0	[B, R]	1RR10101 4 0
	D Register Offset	D,R	1RR01011 4 0	[D, R]	1RR11011 7 0
Auto Increment/Decrement R	Increment By 1	,R+	1RR00000 2 0	not allowed	
	Increment By 2	,R++	1RR00001 3 0	[,R++]	1RR10001 6 0
	Decrement By 1	,-R	1RR00010 2 0	not allowed	
	Decrement By 2	,--R	1RR00011 3 0	[,-R]	1RR10011 6 0
Constant Offset From PC (2's Complement Offsets)	8 Bit Offset	n, PCR	1xx01100 1 1	[n, PCR]	1xx11100 4 1
	16 Bit Offset	n, PCR	1xx01101 5 2	[n, PCR]	1xx11101 8 2
Extended Indirect	16 Bit Address			[n]	10011111 5 2

R = X, Y, U or S      RR:  
 x = Don't Care      00 = X  
                           01 = Y  
                           10 = U  
                           11 = S

\* and † indicate the number of additional cycles and bytes for the particular variation.

the effective address of the operand. The contents of both the accumulator and the pointer register are unchanged by the addition. The postbyte specifies which accumulator to use as an offset and no additional bytes are required. The advantage of an accumulator offset is that the value of the offset can be calculated by a program at run-time.

Some examples are:

```
LDA B, Y
LDX D, Y
LEAX B, X
```

**Auto Increment/Decrement Indexed:** In the auto increment addressing mode, the pointer register contains the address of the operand. Then, after the pointer register is used it is incremented by one or two. This addressing mode is useful in stepping through tables, moving data, or for the creation of software stacks. In auto decrement, the pointer register is decremented prior to use as the address of the data. The use of auto decrement is similar to that of auto increment; but the tables, etc, are scanned from high to low addresses. The size of the increment/decrement can be either one or two to allow for tables of either 8- or 16-bit data to be accessed, selectable by the programmer. The pre-decrement, post-increment nature of these modes allow them to be used to create additional software stacks that behave identically to the U and S stacks.

Some examples of the auto increment/decrement addressing modes are:

```
LDA X+
STD Y++
LDB -Y
LDX --S
```

Care should be taken in performing operations on 16-bit pointer registers (X, Y, U, S) where the same register is used to calculate the effective address.

Consider the following instruction:

```
STX 0, X++ (X initialized to 0)
```

The desired result is to store a 0 in locations \$0000 and \$0001 then increment X to point to \$0002. In reality, the following occurs:

- 0→temp calculate the EA; temp is a holding register
- X+2→X perform autoincrement
- X→(temp) do store operation

**Indexed Indirect**

All of the indexing modes with the exception of

auto increment/decrement by one, or a ±4-bit offset may have an additional level of indirection specified. In indirect addressing, the effective address is contained at the location specified by the contents of the index register plus any offset. In the example below, the A accumulator is loaded indirectly using an effective address calculated from the index register and an offset.

Before Execution:

```
A = X × X (don't care)
X = $F000
```

```
$0100 LDA [$10, X] EA is now $F010
$F010 $F1 $F150 is now the
$F011 $50 new EA
$F150 $AA
```

After Execution:

```
A = $AA (Actual Data Loaded)
X = $F000
```

All modes of indexed indirect are included except those which are meaningless (e.g., auto increment/decrement by 1 indirect). Some examples of indexed indirect are:

```
LDA [X]
LDD [10,S]
LDA [B;Y]
LDD [X++]
```

**Relative Addressing**

The byte(s) following the branch opcode is (are) treated as a signed offset which may be added to the program counter. If the branch condition is true then the calculated address (PC + signed offset) is loaded into the program counter. Program execution continues at the new location as indicated by the PC. Short (1 byte offset) and long (2 bytes offset) relative addressing modes are available. All of memory can be reached in long relative addressing as an effective address is interpreted modulo 2<sup>16</sup>. Some examples of relative addressing are:

```
BEQ CAT (short)
BGT DOG (short)
CAT LBEQ RAT (long)
DOG LBGT RABBIT (long)
```

```
RAT NOP
RABBIT NOP
```

**Program Counter Relative**

The PC can be used as the pointer register with 8- or 16-bit signed offsets. As in relative addressing, the offset is added to the current PC to create the effective address. The effective address is then used as the address of the operand or data. Program counter relative addressing is used for writing position independent programs. Tables related to a particular routine will maintain the same relationship after the routine is moved, if referenced rela-

tive to the program counter. Examples are:

```
LDA    CAT, PCR
LEAX   TABLE, PCR
```

Since program counter relative is a type of indexing, an additional level of indirection is available.

```
LDA    [CAT, PCR]
LDU    [DOG, PCR]
```

**HD6309 Instruction Set**

The instruction set of the HD6309 is similar to that of the HD6800 and is upward compatible at the source code level. The number of opcodes has been reduced from 72 to 59, but because of the expanded architecture and additional addressing modes, the number of available opcodes (with different addressing modes) has risen from 197 to 1464.

Some of the instructions and addressing modes are described in detail below:

**PSHU/PSHS**

The push instructions can push onto either the

hardware stack (S) or user stack (U) any single register, or set of registers with a single instruction.

**PULU/PULS**

The pull instructions have the same capability of the push instruction, in reverse order. The byte immediately following the push or pull opcode determines which register or registers are to be pushed or pulled. The actual PUSH/PULL sequence is fixed: each bit defines a unique register to push or pull, as shown in figure 16.

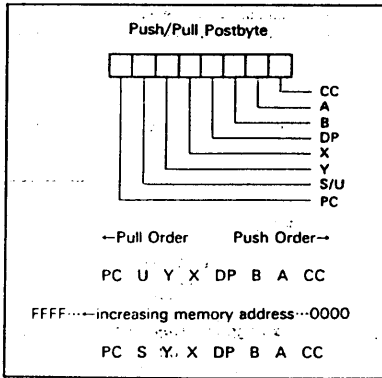

Figure 16. Push and Pull Order



Bât Evolic 1 - 165, Bd de Valmy  
 92706 COLOMBES CEDEX  
 Tél. (1) 47.60.12.47 - Fax. (1) 47.60.15.82  
 TELEX 613600 F

**TFR/EXG**

Within the HD6309, any register may be transferred to or exchanged with another of like-size: i. e., 8-bit to 8-bit or 16-bit to 16-bit. Bits 4-7 of the postbyte define the source register, while bits 0-3 represent the destination register (figure 17). They are denoted as follows:

0000-D	0101-PC
0001-X	1000-A
0010-Y	1001-B
0011-U	1010-CC
0100-S	1011-DP

Note: All other combinations are undefined and invalid.

**LEAX/LEAY/LEAU/LEAS**

The LEA (load effective address) works by calculating the effective address used in an indexed instruction and stores that address value, rather than the data at that address, in a pointer register. This makes all the features of the internal addressing hardware available to the programmer. Some of the implications of this instruction are illustrated in table 5.

The LEA instruction also allows the user to access data in a position independent manner. For example:

```
LEAX MSG1, PCR
LBSR PDATA(Print message routine)
```

```
MSG1 FCC 'MESSAGE'
```

This sample program prints: 'MESSAGE'. By

writing MSG1, PCR, the assembler computes the distance between the present address and MSG1. This result is placed as a constant into the LEAX instruction which will be indexed from the PC value at the time of execution. No matter where the code is located, when it is executed, the computed offset from the PC will put the absolute address of MSG1 into the X pointer register. This code is totally position independent.

The LEA instructions are very powerful and use an internal holding register (temp). Care must be exercised when using the LEA instructions with the autoincrement and autodecrement addressing modes due to the sequence of internal operations. The LEA internal sequence is outlined as follows:

- LEAa ,b+ (any of the 16-bit pointer registers X, Y, U, or S may be substituted for a and b)
1. b→temp (calculate the EA)
  2. b + 1→b (modify b, postincrement)
  3. temp →a (load a)
- LEAa ,-b
1. b - 1 →temp (calculate EA with predecrement)
  2. b - 1 →b (modify b, predecrement)
  3. temp →a (load a)

Autoincrement-by-two and autodecrement-by-two instructions work similarly. Note that LEAX, X+ does not change X, however LEAX, -X does decrement X. LEAX 1, X should be used to increment X by one.

**MUL**

Multiplies the unsigned binary numbers in the A

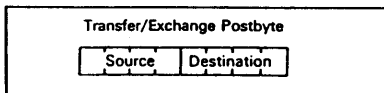

Figure 17. TFR/EXG Format

Table 5. LEA Examples

Instruction	Operation	Comment
LEAX 10, X	X+10→X	Adds 5-bit constant 10 to X
LEAX 500, X	X+500→X	Adds 16-bit constant 500 to X
LEAY A, Y	Y+A→Y	Adds 8-bit A accumulator to Y
LEAY D, Y	Y+D→Y	Adds 16-bit D accumulator to Y
LEAU-10, U	U-10→U	Subtracts 10 from U
LEAS-10, S	S-10→S	Used to reserve area on stack
LEAS 10, S	S+10→S	Used to 'clean up' stack
LEAX 5, S	S+5→X	Transfers as well as adds

and B accumulator and places the unsigned result into the 16-bit D accumulator. This unsigned multiply also allows multiple-precision multiplications.

**Long And Short Relative Branches**

The HD6309 has the capability of program counter relative branching throughout the entire memory map. In this mode, if the branch is to be taken, the 8- or 16-bit signed offset is added to the value of the program counter to be used as the effective address. This allows the program to branch anywhere in the 64k memory map. Position independent code can be easily generated through the use of relative branching. Both short (8-bit) and long (16-bit) branches are available.

**SYNC**

After encountering a sync instruction, the MPU enters a sync state, stops processing instructions, and waits for an interrupt. If the pending interrupt

is non-maskable ( $\overline{\text{NMI}}$ ) or maskable ( $\overline{\text{FIRQ}}$ ,  $\overline{\text{IRQ}}$ ) with its mask bit (F or I) clear, the processor will clear the sync state and perform the normal interrupt stacking and service routine. Since  $\overline{\text{FIRQ}}$  and  $\overline{\text{IRQ}}$  are not edge-triggered, a low level with a minimum duration of three bus cycles is required to assure that the interrupt will be taken. If the pending interrupt is maskable ( $\overline{\text{FIRQ}}$ ,  $\overline{\text{IRQ}}$ ) with its mask bit (F or I) set, the processor will clear the sync state and continue processing by executing the next inline instruction. Figure 18 depicts sync timing.

**Software Interrupt**

A software interrupt instruction will cause an interrupt, and its associated vector fetch. These software interrupts are useful in operating system calls, software debugging, trace operations, memory mapping, and software development systems. Three levels of SWI are available on this HD6309, and are prioritized in the following order: SWI, SWI2, SWI3.

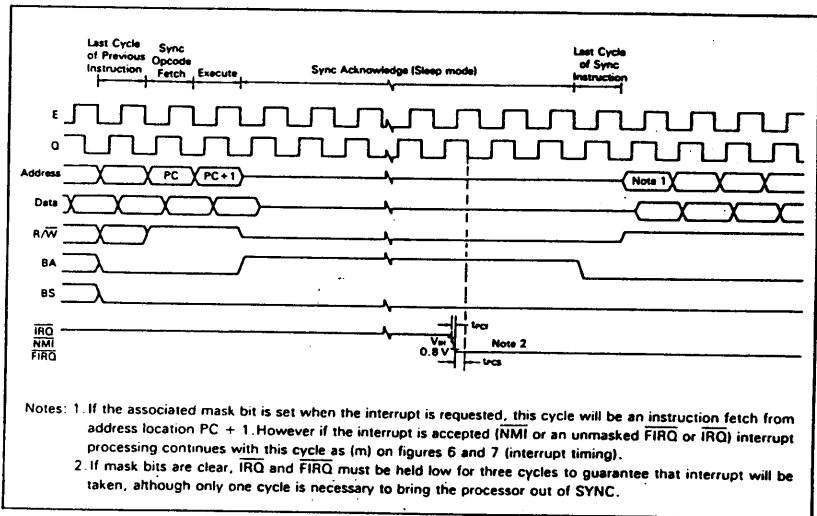

Figure 18. Sync Timing

# HD6309

## 16-Bit Operation

The HD6309 has the capability of processing 16-bit data. These instructions include loads, stores, compares, adds, subtracts, transfers, exchanges, pushes and pulls.

## Cycle-by-Cycle Operation

The address bus cycle-by-cycle performance chart illustrates the memory-access sequence corresponding to each possible instruction and addressing mode in the HD6309. Each instruction begins with an opcode fetch. While that opcode is being internally decoded, the next program byte is always fetched. (Most instructions will use the next byte, so this technique considerably speeds throughput.) Next, the operation of each opcode will follow the flow chart. VMA is an indication of  $FFFF_{16}$  on the address bus, R/W = high and BS = low. The following examples illustrate the use of the chart: see figure 19.

### Example 1: LBSR (Branch Taken)

Before Execution SP = F000

\$8000		LBSR	CAT
		.	.
		.	.
\$A000		CAT	.

### Cycle-by-Cycle Flow

Cycle #	Address	Data	R/W	Description
1	8000	17	1	Opcode Fetch
2	8001	1F	1	Offset High Byte
3	8002	FD	1	Offset Low Byte
4	FFFF	*	1	VMA Cycle
5	FFFF	*	1	VMA Cycle
6	FFFF	*	1	VMA Cycle
7	FFFF	*	1	VMA Cycle
8	EFFE	03	0	Stack Low Order Byte of Return Address
9	EFFE	80	0	Stack High Order Byte of Return Address

### Example 2: DEC (Extended)

\$8000	DEC	\$A000
\$A000	FCB	\$80

### Cycle-by-Cycle Flow

Cycle #	Address	Data	R/W	Description
1	8000	7A	1	Opcode Fetch
2	8001	A0	1	Operand Address, High Byte
3	8002	00	1	Operand Address, Low Byte
4	FFFF	*	1	VMA Cycle
5	A000	80	1	Read the Data
6	FFFF	*	1	VMA Cycle
7	A000	7F	0	Store the Decrement Data

\*. The data bus has the data at that particular address.

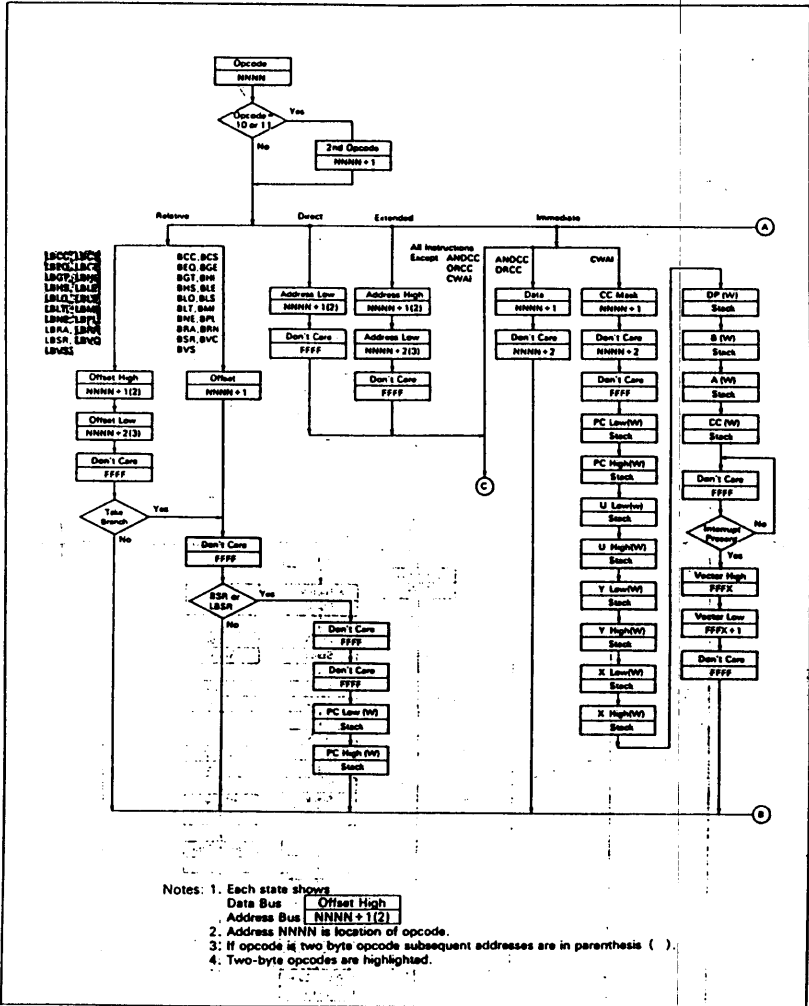

Figure 19. Cycle-by-Cycle Performance

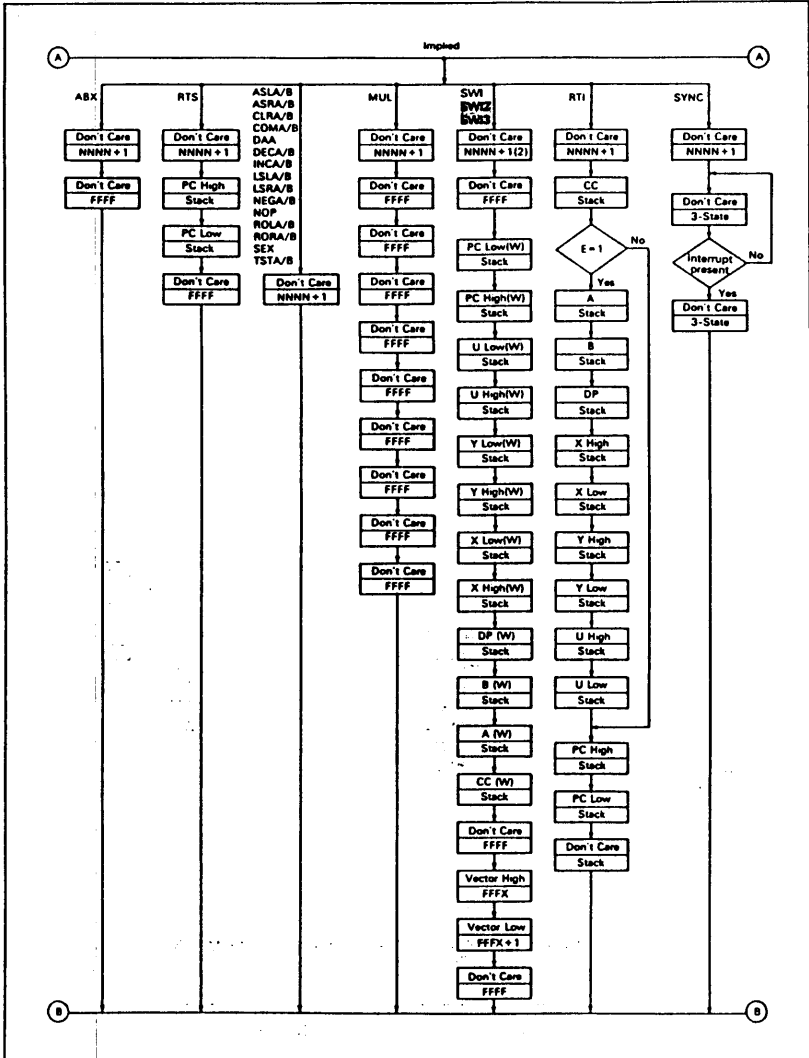

Figure 19. Cycle-by-Cycle Performance (Cont.)

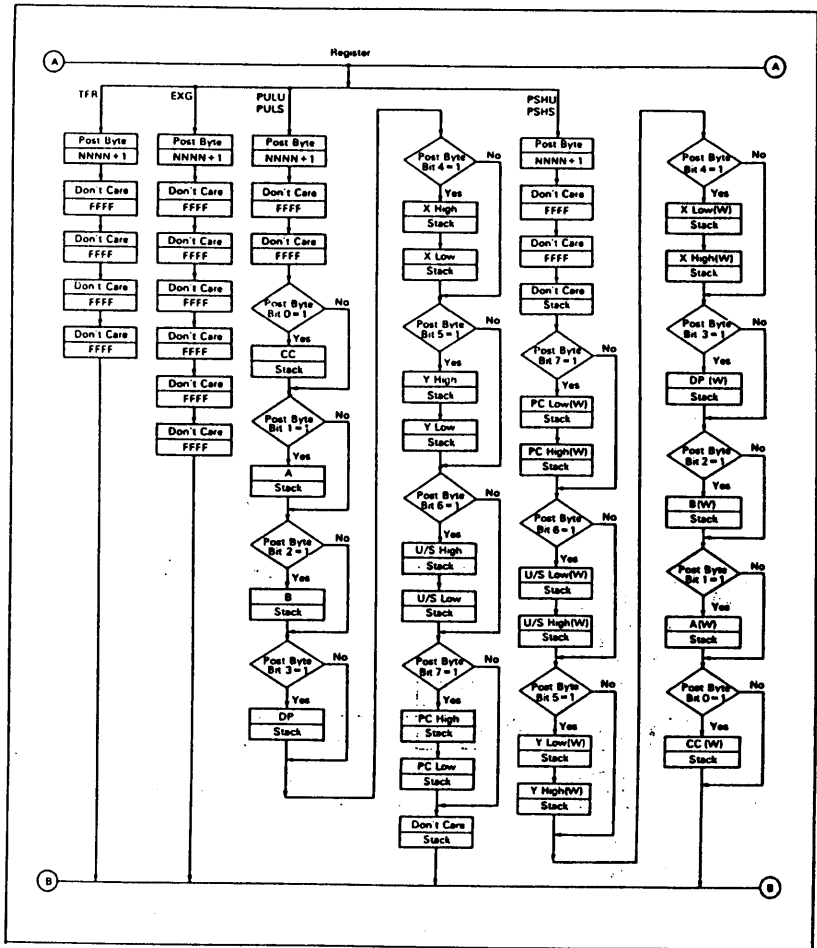

Figure 19. Cycle-by-Cycle Performance (Cont.)

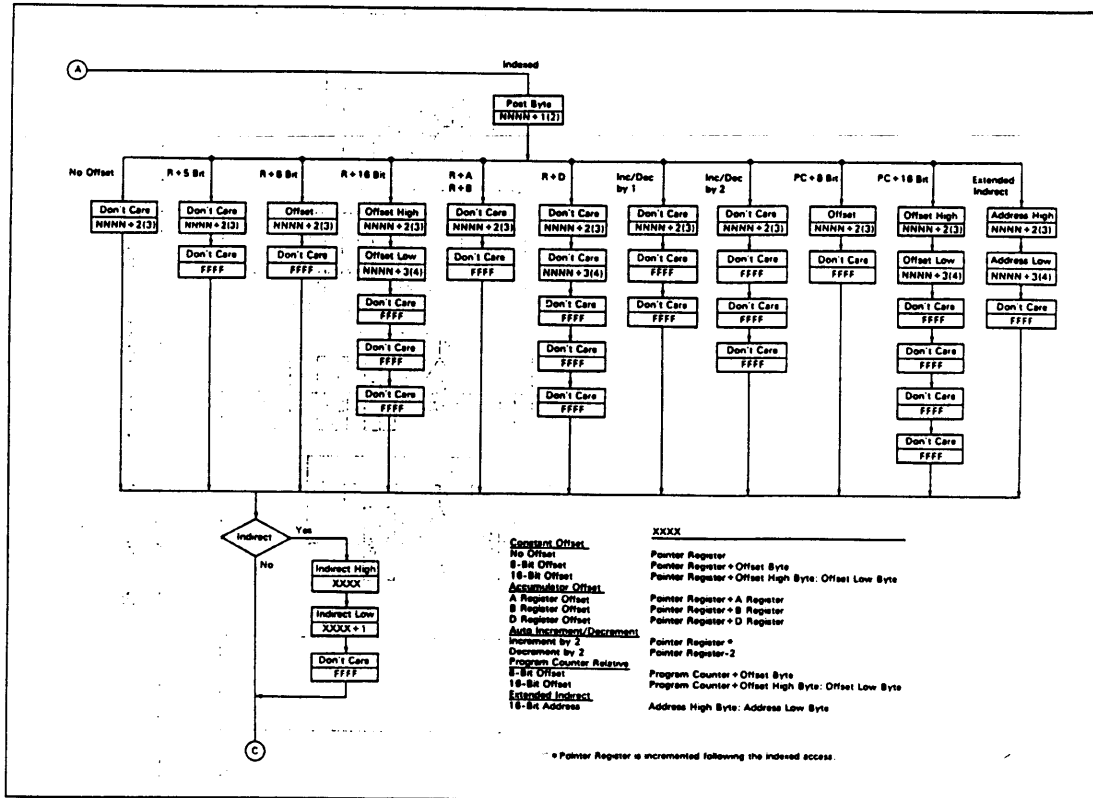

Figure 19. Cycle-by-Cycle Performance (Cont.)

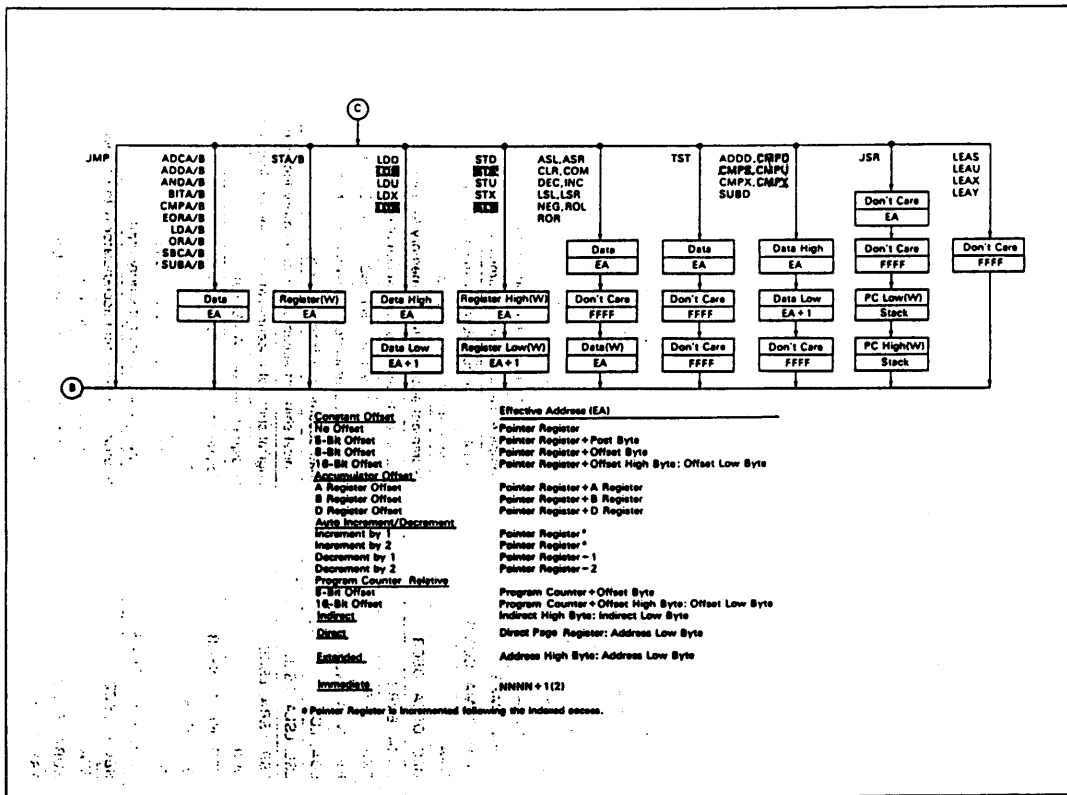

Figure 19. Cycle-by-Cycle Performance (Cont.)

## Sleep Mode

During the interrupt wait period in the SYNC instruction (the sync state) and in the CWAI instruction (the wait state), MPU operation is halted and goes to the sleep mode. However, the state of I/O pins is the same as that of the HD6809 in this mode.

## HD6309 Instruction set Tables

The instructions of the HD6309 have been broken down into five different categories. They are as follows:

- 8-Bit operation (table 6)
- 16-Bit operation (table 7)
- Index register/stack pointer instructions (table 8)
- Relative branches (long or short) (table 9)
- Miscellaneous instructions (table 10)

HD6309 instruction set tables and Hexadecimal Values of instructions are shown in table 11 and table 12.

Table 6. 8-Bit Accumulator and Memory Instructions

Mnemonic(s)	Operation
ADCA, ADCB	Add memory to accumulator with carry
ADDA, ADDB	Add memory to accumulator
ANDA, ANDB	AND memory with accumulator
ASL, ASLA, ASLB	Arithmetic shift of accumulator or memory left
ASR, ASRA, ASRB	Arithmetic shift of accumulator or memory right
BITA, BITB	Bit test memory with accumulator
CLR, CLRA, CLRB	Clear accumulator or memory location
CMPA, CMPB	Compare memory from accumulator
COM, COMA, COMB	Complement accumulator or memory location
DAA	Decimal adjust A accumulator
DEC, DECA, DECB	Decrement accumulator or memory location
EORA, EORB	Exclusive OR memory with accumulator
EXG R1, R2	Exchange R1 with R2 (R1, R2 = A, B, CC, DP)
INC, INCA, INCB	Increment accumulator or memory location
LDA, LDB	Load accumulator from memory
LSL, LSLA, LSLB	Logical shift left accumulator or memory location
LSR, LSRA, LSRB	Logical shift right accumulator or memory location
MUL	Unsigned multiply (A × B → D)
NEG, NEGA, NEGB	Negate accumulator or memory
ORA, ORB	OR memory with accumulator
ROL, ROLA, ROLB	Rotate accumulator or memory left
ROR, RORA, RORB	Rotate accumulator or memory right
SBCA, SBCB	Subtract memory from accumulator with borrow
STA, STB	Store accumulator to memory
SUBA, SUBB	Subtract memory from accumulator
TST, TSTA, TSTB	Test accumulator or memory location
TFR R1, R2	Transfer R1 or R2 (R1, R2 = A, B, CC, DP)

Note: A, B, CC or DP may be pushed to (pulled from) either stack with PSHS, PSBU (PULS, PULU) instructions.

Table 7. 16-Bit Accumulator and Memory Instructions

Mnemonic(s)	Operation
ADDD	Add memory to D accumulator
CMPD	Compare memory from D accumulator
EXG D, R	Exchange D with X, Y, S, U or PC
LDD	Load D accumulator from memory
SEX	Sign Extend B accumulator into A accumulator
STD	Store D accumulator to memory
SUBD	Subtract memory from D accumulator
TFR D, R	Transfer D to X, Y, S, U or PC
TFR R, D	Transfer X, Y, S, U or PC to D

Note: D may be pushed (pulled) to either stack with PSHS, PSHU (PULS, PULU) instructions.

Table 8. Index Register/Stack Pointer Instructions

Mnemonic(s)	Operation
CMPX, CMPI	Compare memory from stack pointer
CMPX, CMPI	Compare memory from index register
EXG R1, R2	Exchange D, X, Y, S, U or PC with D, X, Y, S, U or PC
LEAS, LEAU	Load effective address into stack pointer
LEAX, LEAY	Load effective address into index register
LDS, LDU	Load stack pointer from memory
LDX, LDY	Load index register from memory
PSHS	Push A, B, CC, DP, D, X, Y, U or PC onto hardware stack
PSHU	Push A, B, CC, DP, D, X, Y, S or PC onto user stack
PULS	Pull A, B, CC, DP, D, X, Y, U or PC from hardware stack
PULU	Pull A, B, CC, DP, D, X, Y, S or PC from user stack
STS, STU	Store stack pointer to memory
STX, STY	Store index register to memory
TFR R1, R2	Transfer D, X, Y, S, U or PC to D, X, Y, S, U or PC
ABX	Add B accumulator to X (unsigned)







Table 9. Branch Instructions

Mnemonic(s)	Operation
<b>Simple Branches</b>	
BEQ, LBEQ	Branch if equal
BNE, LBNE	Branch if not equal
BMI, LBMI	Branch if minus
BPL, LBPL	Branch if plus
BCS, LBCS	Branch if carry set
BCC, LBCC	Branch if carry clear
BVS, LBVS	Branch if overflow set
BVC, LBVC	Branch if overflow clear
<b>Signed Branches</b>	
BGT, LBGT	Branch if greater (signed)
BGE, LBGE	Branch if greater than or equal (signed)
BEQ, LBEQ	Branch if equal
BLE, LBLE	Branch if less than or equal (signed)
BLT, LBLT	Branch if less than (signed)
<b>Unsigned Branches</b>	
BHI, LBHI	Branch if higher (unsigned)
BHS, LBHS	Branch if higher or same (unsigned)
BEQ, LBEQ	Branch if equal
BLS, LBLS	Branch if lower or same (unsigned)
BLO, LBLO	Branch if lower (unsigned)
<b>Other Branches</b>	
BSR, LBSR	Branch to subroutine
BRA, LBRA	Branch always
BRN, LBRN	Branch never

Table 10. Miscellaneous Instructions

Mnemonic(s)	Operation
ANDCC	AND condition code register
CWAI	AND condition code register, then wait for interrupt
NOP	No operation
ORCC	OR condition code register
JMP	Jump
JSR	Jump to subroutine
RTI	Return from interrupt
RTS	Return from subroutine
SWI, SWI2, SWI3	Software interrupt (absolute indirect)
SYNC	Synchronize with interrupt line

Table 11. HD6309 Instruction Set

















Instruction/ Forms	HD6309 Addressing Modes						Description	5 3 2 1 0				
	Implied	Direct	Extended	Immediate	Indexed <sup>①</sup>	Relative		H	N	Z	V	C
	OP ~ I	OP ~ I	OP ~ I	OP ~ I	OP ~ I	OP ~② I						
ABX	3A 3 1						B+X-X (Unsigned)	•	•	•	•	•
ADC ADCA ADCB		99 4 2 D9 4 2	89 5 3 F9 5 3	89 2 2 C9 2 2	A9 4+2+ E9 4+2+		A+M+C-A B+M+C-8	•	•	•	•	•
ADD ADDA ADDB ADDD		98 4 2 D8 4 2 D3 6 2	88 5 3 F8 5 3 F3 7 3	88 2 2 C8 2 2 C3 4 3	AB 4+2+ EB 4+2+ E3 6+2+		A+M-A B+M-B D+M: M+1-D	•	•	•	•	•
AND ANDA ANDB ANDCC		94 4 2 D4 4 2	84 5 3 F4 5 3	84 2 2 C4 2 2 1C 3 2	A4 4+2+ E4 4+2+		A&M-A B&M-B CC&MM-CC	•	•	•	•	•
ASL ASLA ASLB ASL	48 2 1 58 2 1					68 6+2+	A)  B)  M) 	•	•	•	•	•
ASR ASRA ASRB ASR	47 2 1 57 2 1	08 6 2	78 7 3			67 6+2+	A)  B)  M) 	•	•	•	•	•
BCC BCC LBCC						24 3 2 10 5(6) 4 24	Branch C=0 Long Branch C=0	•	•	•	•	•
BCS BCS LBCS						25 3 2 10 5(6) 4 25	Branch C=1 Long Branch C=1	•	•	•	•	•
BEQ BEQ LBEQ						27 3 2 10 5(6) 4 27	Branch Z=1 Long Branch Z=1	•	•	•	•	•
BGE BGE LBGE						2C 3 2 10 5(6) 4 2C	Branch N&V=0 Long Branch N&V=0	•	•	•	•	•
BGT BG LBGT						2E 3 2 10 5(6) 4 2E	Branch ZV(N&V)=0 Long Branch ZV(N&V)=0	•	•	•	•	•
BHI BHI LBHI						22 3 2 10 5(6) 4 22	Branch CVZ=0 Long Branch CVZ=0	•	•	•	•	•
BHS BHS LBHS						24 3 2 10 5(6) 4 24	Branch C=0 Long Branch C=0	•	•	•	•	•
BIT BITA BITB		95 4 2 D5 4 2	85 5 3 F5 5 3	85 2 2 C5 2 2	A5 4+2+ E5 4+2+		Bit Test (A)M(A) Bit Test (B)M(B)	•	•	•	•	•
BLE BLE LBLE						2F 3 2 10 5(6) 4 2F	Branch ZV(N&V)=1 Long Branch ZV(N&V)=1	•	•	•	•	•
BLO BLO LBLO						25 3 2 10 5(6) 4 25	Branch C=1 Long Branch C=1	•	•	•	•	•
BLS BLS LBLS						23 3 2 10 5(6) 4 23	Branch CVZ=1 Long Branch CVZ=1	•	•	•	•	•
BLT BLT LBLT						2D 3 2 10 5(6) 4 2D	Branch N&V=1 Long Branch N&V=1	•	•	•	•	•
BMI BMI LBMI						28 3 2 10 5(6) 4 28	Branch N=1 Long Branch N=1	•	•	•	•	•

# HD6309

Table 11. HD6309 Instruction Set (Cont.)

Instruction/ Forms	HD6309 Addressing Modes						Description	5 3 2 1 0										
	Implied		Direct		Extended			Immediate		Indexed <sup>D</sup>		Relative		H	N	Z	V	C
	OP	~ /	OP	~ /	OP	~ /		OP	~ /	OP	~ /	OP	~ /					
BNE BNE LBNE											26 3 2 10 5(6) 4 26	Branch Z=0 Long Branch Z=0	•	•	•	•	•	•
BPL BPL LBPL											2A 3 2 10 5(6) 4 2A	Branch N=0 Long Branch N=0	•	•	•	•	•	•
BRA BRA LBRA											20 3 2 16 5 3	Branch Always Long Branch Always	•	•	•	•	•	•
BRN BRN LBRN											21 3 2 10 5 4 21	Branch Never Long Branch Never	•	•	•	•	•	•
BSR BSR LBSR											8D 7 2 17 9 3	Branch to Subroutine Long Branch to Subroutine	•	•	•	•	•	•
BVC BVC LBVC											28 3 2 10 5(6) 4 28	Branch V=0 Long Branch V=0	•	•	•	•	•	•
BVS BVS LBVS											29 3 2 10 5(6) 4 29	Branch V=1 Long Branch V=1	•	•	•	•	•	•
CLR CLRA CLRB CLR	4F 2 1 5F 2 1												0-A 0-B 0-M	• 0 1 0 0 • 0 1 0 0 • 0 1 0 0				
CMP CMPA CMPB CMPD		91 4 2 D1 4 2 10 7 3	B1 5 3 F1 5 3 10 8 4	81 2 2 C1 2 2 10 5 4	A1 4+2+ E1 4+2+ 10 7+3+							Compare M from A Compare M from B Compare M:M+1 from D	• 1 1 1 1 • 1 1 1 1 • 1 1 1 1 • 1 1 1 1					
CMPS		11 7 3	11 8 4	11 5 4	11 7+3+							Compare M:M+1 from S	• 1 1 1 1					
CMPU		11 7 3	11 8 4	11 5 4	11 7+3+							Compare M:M+1 from U	• 1 1 1 1					
CMPX		9C 6 2	8C 7 3	8C 4 3	AC 6+2+							Compare M:M+1 from X	• 1 1 1 1					
CMPY		10 7 3 9C	10 8 4 8C	10 5 4 8C	10 7+3+ AC							Compare M:M+1 from Y	• 1 1 1 1					
COM COMA COMB COM	43 2 1 53 2 1												A-A B-B M-M	• 1 1 0 1 • 1 1 0 1 • 1 1 0 1				
CWAI		03 6 2	73 7 3					63 6+2+				CC\MM-CC (except I-E)	⌈ 0 ⌋					
DAA	19 2 1											Wait for Interrupt Decimal Adjust A	• 1 1 0 1					
DEC DECA DECB DEC	4A 2 1 5A 2 1												A-1-A B-1-B M-1-M	• 1 1 1 0 • 1 1 1 0 • 1 1 1 0				
EOR EORA EORB		98 4 2 DB 4 2	88 5 3 FB 5 3	88 2 2 CB 2 2	A8 4+2+ E8 4+2+							A ⊕ M-A B ⊕ M-B	• 1 1 0 0 • 1 1 0 0					
EXG R1, R2	1E 7 2											R1-R2 <sup>2</sup>	⌈ 6 ⌋					
INC INCA INCB INC	4C 2 1 5C 2 1												A+1-A B+1-B M+1-M	• 1 1 1 0 • 1 1 1 0 • 1 1 1 0				
JMP		0E 3 2	7E 4 3					6E 3+2+				EA <sup>2</sup> -PC	• • • • •					
JSR		9D 7 2	8D 8 3					AD 7+2+				Jump to Subroutine	• • • • •					

Table 11. HD6309 Instruction Set (Cont.)

Instruction/ Forms	HD6309 Addressing Modes						Description	5	3	2	1	0						
	Implied		Direct		Extended								Immediate		Indexed <sup>D</sup>		Relative	
	OP	~ /	OP	~ /	OP	~ /							OP	~ /	OP	~ /	OP	~ /
LD	LDA	96	4 2	B6	5 3	86	2 2	A6	4+ 2+	M-A	●	1	1	0	●			
	LDB	D6	4 2	F6	5 3	C6	2 2	E6	4+ 2+	M-B	●	1	1	0	●			
	LDD	DC	5 2	FC	6 3	CC	3 3	EC	5+ 2+	M:M+1-D	●	1	1	0	●			
	LDS	10	6 3	10	7 4	10	4 4	10	6+ 3+	M:M+1-S	●	1	1	0	●			
	LDU	DE	5 2	FE	6 3	CE	3 3	EE	5+ 2+	M:M+1-U	●	1	1	0	●			
	LDX	9E	5 2	BE	6 3	8E	3 3	AE	5+ 2+	M:M+1-X	●	1	1	0	●			
	LDY	10	6 3	10	7 4	10	4 4	10	6+ 3+	M:M+1-Y	●	1	1	0	●			
		9E		BE		8E		AE										
LEA	LEAS							32	4+ 2+	EA <sup>2</sup> -S	●	●	●	●	●			
	LEAU							33	4+ 2+	EA <sup>2</sup> -U	●	●	●	●	●			
	LEAX							30	4+ 2+	EA <sup>2</sup> -X	●	●	●	●	●			
	LEAY							31	4+ 2+	EA <sup>2</sup> -Y	●	●	●	●	●			
LSL	LSLA	48	2 1							A }  -0	●	1	1	1	1			
	LSLB	58	2 1							B }  -0	●	1	1	1	1			
	LSL			08	6 2	78	7 3	68	6+ 2+	M }  -0	●	1	1	1	1			
LSR	LSRA	44	2 1							A }  -0	●	0	1	●	1			
	LSRB	54	2 1							B }  -0	●	0	1	●	1			
	LSR			04	6 2	74	7 3	64	6+ 2+	M }  -0	●	0	1	●	1			
MUL		3D	11 1							A×B-D (Unassigned)	●	●	1	●	●			
NEG	NEGA	40	2 1							A+1-A	⊕	1	1	1	1			
	NEGB	50	2 1							B+1-B	⊕	1	1	1	1			
	NEG			00	6 2	70	7 3	60	6+ 2+	M+1-M	⊕	1	1	1	1			
NOP		12	2 1							No Operation	●	●	●	●	●			
OR	ORA			9A	4 2	BA	5 3	8A	2 2	AA 4+ 2+	AVM-A	●	1	1	0	●		
	ORB			DA	4 2	FA	5 3	CA	2 2	EA 4+ 2+	BVM-B	●	1	1	0	●		
	ORCC							1A	3 2		CCVIMM-CC		●	●	●	●		
PSH	PSHS	34	5+ <sup>2</sup> 2							Push Registers on S Stack	●	●	●	●	●			
	PSHU	36	5+ <sup>2</sup> 2							Push Registers on U Stack	●	●	●	●	●			
PUL	PULS	35	5+ <sup>2</sup> 2							Pull Registers from S Stack		●	●	●	●			
	PULU	37	5+ <sup>2</sup> 2							Pull Registers from U Stack		●	●	●	●			
ROL	ROLA	49	2 1							A }  -0	●	1	1	1	1			
	ROLB	59	2 1							B }  -0	●	1	1	1	1			
	ROL			09	6 2	79	7 3	69	6+ 2+	M }  -0	●	1	1	1	1			
ROR	RORA	46	2 1							A }  -0	●	1	1	●	1			
	RORB	56	2 1							B }  -0	●	1	1	●	1			
	ROR			06	6 2	76	7 3	66	6+ 2+	M }  -0	●	1	1	●	1			
RTI		3B	6/5 1							Return from Interrupt		●	●	●	●			
RTS		39	5 1							Return from Subroutine	●	●	●	●	●			
SBC	SBCA	92	4 2	B2	5 3	82	2 2	A2	4+ 2+	A-M-C-A	⊖	1	1	1	1			
	SBCB	02	4 2	F2	5 3	C2	2 2	E2	4+ 2+	B-M-C-B	⊖	1	1	1	1			
SEX		1D	2 1							Sign Extend B into A	●	1	1	●	●			
ST	STA	97	4 2	B7	5 3			A7	4+ 2+	A-M	●	1	1	0	●			
	STB	D7	4 2	F7	5 3			E7	4+ 2+	B-M	●	1	1	0	●			
	STD	DD	5 2	FD	6 3			ED	5+ 2+	D-M:M+1	●	1	1	0	●			
	STS	10	6 3	10	7 4			10	6+ 3+	S-M:M+1	●	1	1	0	●			
	STU	DF	5 2	FF	6 3			EF	5+ 2+	U-M:M+1	●	1	1	0	●			
	STX	9F	5 2	BF	6 3			AF	5+ 2+	X-M:M+1	●	1	1	0	●			
	STY	10	6 3	10	7 4			10	6+ 3+	Y-M:M+1	●	1	1	0	●			
		9F		BF				AF										

# HD6309

Table 11. HD6309 Instruction Set (Cont.)

Instruction/ Forms	HD6309 Addressing Modes						Description					
	Implied	Direct	Extended	Immediate	Indexed <sup>①</sup>	Relative		5	3	2	1	0
	OP ~ I	OP ~ I	OP ~ I	OP ~ I	OP ~ I	OP ~ I		H	N	Z	V	C
SUB SUBA SUBB SUBD		90 4 2 D0 4 2 93 6 2	80 5 3 F0 5 3 83 7 3	80 2 2 C0 2 2 83 4 3	A0 4 + 2+ E0 4 + 2+ A3 6 + 2+		A-M-A B-M-B D-M:M+1-D	0	1	1	1	1
SWI SWI <sup>D</sup> SWI2 <sup>D</sup> SWI3 <sup>D</sup>	3F 19 1 10 20 2 3F 11 20 2 3F						Software Interrupt 1 Software Interrupt 2 Software Interrupt 3	0	0	0	0	0
SYNC	13 2 4 1						Synchronize to Interrupt	0	0	0	0	0
TFR R1, R2	1F 6 2						R1-R2 <sup>②</sup>	-----				
TST TSTA TSTB TST	4D 2 1 5D 2 1	0D 6 2	7D 7 3		6D 6 + 2+		Test A Test B Test M	0	1	1	0	0

Legend: OP	Operation Code (Hexadecimal)	Z	Zero (byte)
~	Number of MPU Cycles	V	Overflow, 2's complement
I	Number of Program Bytes	C	Carry from bit 7
+	Arithmetic Plus	I	Test and set if true, cleared otherwise
-	Arithmetic Minus	●	Not Affected
x	Multiply	CC	Condition Code Register
M	Complement of M	:	Concatenation
-	Transfer Into	∨	Logical or
H	Half-carry (from bit 3)	^	Logical and
N	Negative (sign bit)	⊕	Logical Exclusive or

Notes: ① This column gives a base cycle and byte count. To obtain total count, and the values obtained from the Indexed Addressing Modes table.

② R1 and R2 may be any pair of 8-bit or any pair of 16-bit registers.

The 8-bit registers are: A, B, CC, DP

The 16-bit registers are: X, Y, U, S, D, PC

③ EA is the effective address.

④ The PSH and PUL instructions require 5 cycle plus 1 cycle for each byte pushed or pulled.

⑤ Si6) means: 5 cycles if branch not taken, 6 cycles if taken.

⑥ SWI sets I and F bits, SWI2 and SWI3 do not affect I and F.

⑦ Conditions Codes set as a direct result of the instruction.

⑧ Value of half-carry flag is undefined.

⑨ Special Case-Carry set if b7 is SET.

⑩ Condition Codes set as a direct result of the instruction if CC is specified, and not affected otherwise.

Table 12. Hexadecimal Values of Machine Codes

OP	Mnem	Mode	~	!	OP	Mnem	Mode	~	!	OP	Mnem	Mode	~	!
00	NEG	Direct	6	2	30	LEAX	Indexed	4+	2+	60	NEG	Indexed	6+	2+
01	*	↑			31	LEAY	↑	4+	2+	61	*	↑		
02	*				32	LEAS		4+	2+	62	*			
03	COM		6	2	33	LEAU	Indexed	4+	2+	63	COM		6+	2+
04	LSR		6	2	34	PSHS	Implied	5+	2	64	LSR		6+	2+
05	*				35	PULS		5+	2	65	*			
06	ROR		6	2	36	PSHU		5+	2	66	ROR		6+	2+
07	ASR		6	2	37	PULU		5+	2	67	ASR		6+	2+
08	ASL, LSL		6	2	38	*	↑			68	ASL, LSL		6+	2+
09	ROL		6	2	39	RTS			5	1	69	ROL		6+
0A	DEC		6	2	3A	ABX		3	1	6A	DEC		6+	2+
0B	*				3B	RTI	Implied	6, 15	1	6B	*			
0C	INC		6	2	3C	CWAI	Immed	≥20	2	6C	INC		6+	2+
0D	TST		6	2	3D	MUL	Implied	11	1	6D	TST		6+	2+
0E	JMP		3	2	3E	*				6E	JMP		3+	2+
0F	CLR	Direct	6	2	3F	SWI	Implied	19	1	6F	CLR	Indexed	6+	2+
10	See	-	-	-	40	NEGA	Implied	2	1	70	NEG	Extended	7	3
11	Next Page	-	-	-	41	*				71	*			
12	NOP	Implied	2	1	42	*	↑			72	*			
13	SYNC	Implied	≥4	1	43	COMA			2	1	73	COM		7
14	*				44	LSRA		2	1	74	LSR		7	3
15	*				45	*				75	*			
16	LBRA	Relative	5	3	46	RORA		2	1	76	ROR		7	3
17	LBSR	Relative	9	3	47	ASRA		2	1	77	ASR		7	3
18	*				48	ASLA, LSLA		2	1	78	ASL, LSL		7	3
19	DAA	Implied	2	1	49	ROLA		2	1	79	ROL		7	3
1A	ORCC	Immed	3	2	4A	DECA		2	1	7A	DEC		7	3
1B	*				4B	*				7B	*			
1C	ANDCC	Immed	3	2	4C	INCA		2	1	7C	INC		7	3
1D	SEX	Implied	2	1	4D	TSTA		2	1	7D	TST		7	3
1E	EXG	↑	8	2	4E	*				7E	JMP		4	3
1F	TFR	Implied	6	2	4F	CLRA	Implied	2	1	7F	CLR	Extended	7	3
20	BRA	Relative	3	2	50	NEGB	Implied	2	1	80	SUBA	Immed	2	2
21	BRN		3	2	51	*	↑			81	CMPA		2	2
22	BHI		3	2	52	*					82	SBCA		2
23	BLS		3	2	53	COMB		2	1	83	SUBD		4	3
24	BHS, BCC		3	2	54	LSRB		2	1	84	ANDA		2	2
25	BLO, BCS		3	2	55	*				85	BITA		2	2
26	BNE		3	2	56	RORB		2	1	86	LDA		2	2
27	BEQ		3	2	57	ASRB		2	1	87	*			
28	BVC		3	2	58	ASLB, LSLB		2	1	88	EORA		2	2
29	BVS		3	2	59	ROLB		2	1	89	ADCA		2	2
2A	BPL		3	2	5A	DECB		2	1	8A	ORA		2	2
2B	BMI		3	2	5B	*				8B	ADDA		2	2
2C	BGE		3	2	5C	INCB		2	1	8C	CMPL	Immed	4	3
2D	BLT		3	2	5D	TSTB		2	1	8D	BSR	Relative	7	2
2E	BGT		3	2	5E	*				8E	LDX	Immed	3	3
2F	BLE	Relative	3	2	5F	CLRB	Implied	2	1	8F	*			

Legend: ~ Number of MPU cycles (less possible push pull or indexed-mode cycles)  
 ! Number of program bytes  
 \* Denotes unused opcode

Table 12. Hexadecimal Values of Machine Codes (Cont.)

OP	Mnem	Mode	~	f	OP	Mnem	Mode	~	f	OP	Mnem	Mode	~	f					
90	SUBA	Direct	4	2	C6	LDB	Immed	2	2	FC	LDD	Extended	6	3					
91	CMPA	↑	4	2	C7	*	↑	2	2	FD	STD	↑	6	3					
92	SBCA		4	2	C8	EORB		2	2	FE	LDU		6	3					
93	SUBD		6	2	C9	ADCB		2	2	FF	STU		Extended	6	3				
94	ANDA		4	2	CA	ORB		2	2	2 Bytes Opcode									
95	BITA		4	2	CB	ADDB		2	2										
96	LDA		4	2	CC	LDD		3	3										
97	STA		4	2	CD	*													
98	EORA		4	2	CE	LDU		Immed	3							3			
99	ADCA		4	2	CF	*													
9A	ORA		4	2	D0	SUBB		↑	4							2	1021	LBRN	↑
9B	ADDA	4	2	D1	CMPB	4	2		1022							LBHI	5(6)	4	
9C	CMPX	6	2	D2	SBCB	4	2		1023							LBLS	5(6)	4	
9D	JSR	7	2	D3	ADDD	6	2		1024							LBHS, LBCC	5(6)	4	
9E	LDX	5	2	D4	ANDB	4	2		1025	LBCS, LBLO	5(6)	4							
9F	STX	Direct	5	2	D5	BITB	4		2	1026	LBNE	5(6)	4						
A0	SUBA	↑	4+	2+	D6	LDB	4		2	1027	LBQ	5(6)	4						
A1	CMPA		4+	2+	D7	STB	4		2	1028	LBVC	5(6)	4						
A2	SBCA		4+	2+	D8	EORB	4		2	1029	LBVS	5(6)	4						
A3	SUBD		6+	2+	D9	ADCB	4		2	102A	LBPL	5(6)	4						
A4	ANDA		4+	2+	DA	ORB	4	2	102B	LBMI	5(6)	4							
A5	BITA		4+	2+	DB	ADDB	4	2	102C	LBGE	5(6)	4							
A6	LDA		4+	2+	DC	LDD	5	2	102D	LBLT	5(6)	4							
A7	STA		4+	2+	DD	STD	5	2	102E	LBGT	5(6)	4							
A8	EORA		4+	2+	DE	LDU	Immed	5	2	102F	LBLE	5(6)	4						
A9	ADCA		4+	2+	DF	STU	Direct	5	2	103F	SWI2	20	2						
AA	ORA	4+	2+	E0	SUBB	↑	4+	2+	1083	CMPD	↑	Immed	5	4					
AB	ADDA	4+	2+	E1	CMPB		4+	2+	108C	CMPY		5	4						
AC	CMPX	6+	2+	E2	SBCB		4+	2+	108E	LDY		Immed	4	4					
AD	JSR	7+	2+	E3	ADDD		6+	2+	1088	CMPY		↑	Direct	7	3				
AE	LDX	5+	2+	E4	ANDB		4+	2+	1089	CMPY			7	3					
AF	STX	Indexed	5+	2+	E5		BITB	4+	2+	109E			LDY	Direct	6	3			
B0	SUBA	↑	5	3	E6		LDB	4+	2+	109F			STY	Direct	6	3			
B1	CMPA		5	3	E7		STB	4+	2+	10A3			CMPD	↑	Indexed	7+	3+		
B2	SBCA		5	3	E8		EORB	4+	2+	10AC			CMPY		7+	3+			
B3	SUBD		7	3	E9		ADCB	4+	2+	10AE			LDY		6+	3+			
B4	ANDA		5	3	EA	ORB	4+	2+	10AF	STY	Indexed		6+		3+				
B5	BITA		5	3	EB	ADDB	4+	2+	10B3	CMPD	↑		Extended		8	4			
B6	LDA		5	3	EC	LDD	5+	2+	108C	CMPY			8		4				
B7	STA		5	3	ED	STD	5+	2+	108E	LDY		7	4						
B8	EORA		5	3	EE	LDU	5+	2+	108F	STY		Extended	7		4				
B9	ADCA		5	3	EF	STU	Indexed	5+	2+	10CE		LDS	Immed		4	4			
BA	ORA	5	3	F0	SUBB	↑	5	3	10DE	LDS		Direct	6		3				
BB	ADDA	5	3	F1	CMPB		5	3	10DF	STS		Direct	6	3					
BC	CMPX	7	3	F2	SBCB		5	3	10EE	LDS		Indexed	6+	3+					
BD	JSR	8	3	F3	ADDD		7	3	10EF	STS		Indexed	6+	3+					
BE	LDX	6	3	F4	ANDB		5	3	10FE	LDS		Extended	7	4					
BF	STX	Extended	6	3	F5		BITB	5	3	10FF	STS	Extended	7	4					
C0	SUBB	↑	2	2	F6		LDB	5	3	113F	SWI3	↑	Implied	20	2				
C1	CMPB		2	2	F7		STB	5	3	1183	CMPU		Immed	5	4				
C2	SBCB		2	2	F8		EORB	5	3	118C	CMP5		Immed	5	4				
C3	ADDD		4	3	F9		ADCB	5	3	1193	CMPU		Direct	7	3				
C4	ANDB		2	2	FA	ORB	5	3	119C	CMP5	Direct		7	3					
C5	BITB		Immed	2	2	FB	ADDB	Extended	5	3	11A3		CMPU	Indexed	7+	3+			
											11AC		CMP5	Indexed	7+	3+			
											11B3		CMPU	Extended	8	4			
											118C		CMP5	Extended	8	4			

Note: All unused opcodes are both undefined and illegal.

## Note for Use

### Compatibility with NMOS MPU (HD6809)

The difference between HD6309 (CMOS) and HD6809 (NMOS) is shown in table 13.

Example: CLR (Extended)

\$8000	CLR	\$A000
\$A000	FCB	\$80

### Execution Sequence of CLR Instruction

Cycle-by-cycle flow of CLR instruction (direct, extended, indexed addressing mode) is shown below. In this sequence the contents of the memory location specified by the operand is read before writing 00 into it. Note that status flags, such as IRQ Flag, will be cleared by this extra data read operation when accessing the control/status register (sharing the same address between read and write) of peripheral devices.

Cycle #	Address	Data	R/W	Description
1	8000	7F	1	Opcode Fetch
2	8001	A0	1	Operand Address, High Byte
3	8002	00	1	Operand Address, Low Byte
4	FFFF	*	1	VMA Cycle
5	A000	80	1	Read the Data
6	FFFF	*	1	VMA Cycle
7	A000	00	0	Store Fixed 00 into Specified Location

\* The data bus has the data at that particular address.

Table 13. Difference between HD6309 and HD6809

Item	HD6309 (CMOS)	HD6809 (NMOS)
MRDY	Stretch Unit integral multiples of half (1/2) bus cycles	integral multiples of quarter (1/4) bus cycles
Stretch Time	5 μs max	10 μs max
DMA/BREQ	Auto-refresh None	Executed
External Clock Input	XTAL floating	XTAL grounded

## Application Note for System Design

At the trailing edge of the address bus, the noise pulses may appear on the output signals in HD6309.

Note the noise pulses and the following measures against them.

**Noise Occurrence Condition:** As shown in figure 20, the noise pulses which are 0.8 V or over may appear on E and Q clocks when the address bus changes from high to low.

If the address buses ( $A_0 - A_{15}$ , and  $R/\bar{W}$ ) change from high to low, the transient current flows through the GND. The noise pulses are generated on the LSI's  $V_{SS}$  pins according to the current and to the impedance state of the GND wirings.

Figure 21 shows the noise voltage dependency on the each parameter.

Figure 23 shows the noise voltage dependency on

the load capacitance of the address bus.

**Note:** The noise level should be carefully checked because it depends on the each parameter of actual application system.

### Noise Reduction:

1. Control each parameter such as  $C_d$ ,  $V_{CC}$ ,  $Z_g$  in figure 21, and the noise level is reduced to be allowable.
2. Insert a bypass capacitor between the  $V_{CC}$  and the GND of the HD6309.
3. Connect the CMOS buffer with noise margin to E and Q clocks.
4. Insert the damping resistors to the address bus. That is effective for the noise level to reduce less than 0.8 V. The damping resistor is about 40-50  $\Omega$  on the higher byte of the address bus ( $A_{15} - A_8$ ) and about 130-140  $\Omega$  on the lower byte of the address bus ( $A_7 - A_0$ ), and  $R/\bar{W}$  as shown in figure 22. Electrical characteristics do not change by inserting the damping resistors.

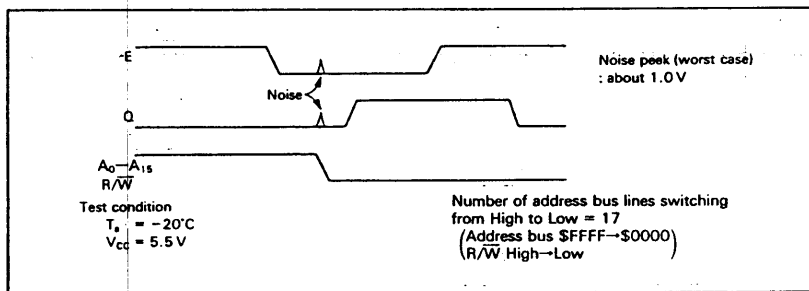

Figure 20. Noise at Address Bus Output Changing

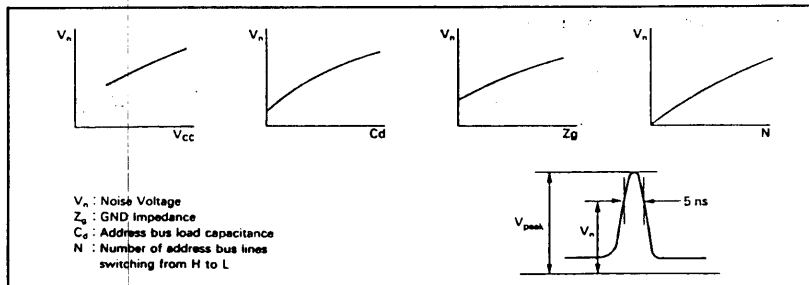

Figure 21. Dependency of the Noise Voltage on Each Parameter

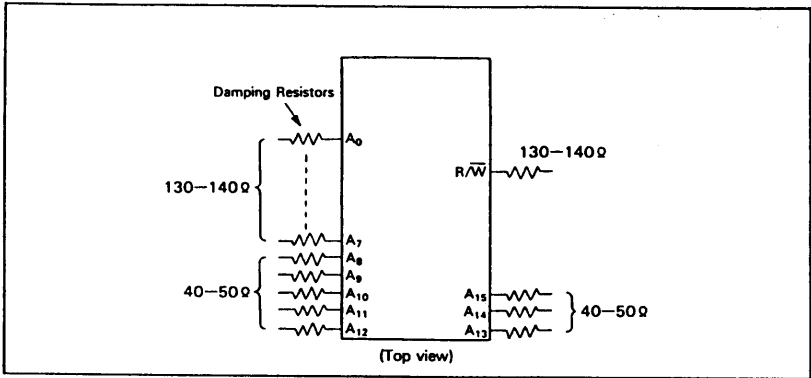

Figure 22. Connecting Damping Resistors to Address Bus

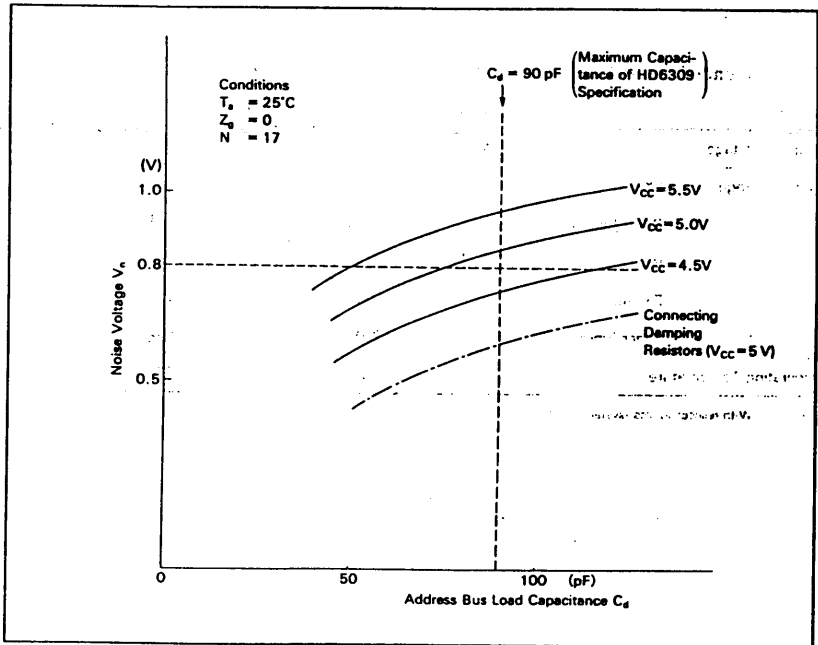

Figure 23. Dependency of the Noise Voltage on the Load Capacitance of the Address Bus

# HD6309

## Absolute Maximum Ratings

Item	Symbol	Value	Unit
Supply Voltage	$V_{CC}^1$	-0.3 to +7.0	V
Input Voltage	$V_{in}^1$	-0.3 to +7.0	V
Maximum Output Current	$ I_o ^2$	5	mA
Maximum Total Output Current	$ \Sigma I_o ^3$	100	mA
Operating Temperature	$T_{opr}$	-20 to +75	°C
Storage Temperature	$T_{stg}$	-55 to +150	°C

- Notes: 1. With respect to  $V_{SS}$  (system GND)  
 2. Maximum output current is the maximum currents which can flow out from one output terminal and I/O common terminal ( $A_0$ - $A_{15}$ ,  $R/\bar{W}$ ,  $D_0$ - $D_7$ , BA, BS, Q, E).  
 3. Maximum total output current is the total sum of output currents which can flow out simultaneously from output terminals and I/O common terminals ( $A_0$ - $A_{15}$ ,  $R/\bar{W}$ ,  $D_0$ - $D_7$ , BA, BS, Q, E).  
 4. Permanent LSI damage may occur if maximum ratings are exceeded. Normal operation should be under recommended operating conditions. If these conditions are exceeded, it could affect reliability of LSI.

## Recommended Operating Conditions

Item	Symbol	Min	Typ	Max	Unit
Supply Voltage	$V_{CC}^1$	4.5	5.0	5.5	V
Input Voltage	EXTAL	$V_{IL}^1$	-0.3	0.6	V
	Other Inputs		-0.3	0.8	V
	$\bar{RES}$	$V_{IH}^1$	$V_{CC}-0.5$	$V_{CC}$	V
	EXTAL		$V_{CC} \times 0.7$	$V_{CC}$	V
	Other Inputs		2.0	$V_{CC}$	V
Operating Temperature	$T_{opr}$	-20	25	75	°C

- Note: 1. With respect to  $V_{SS}$  (system GND)

Electrical Characteristics

DC Characteristics ( $V_{CC}=5.0\text{ V} \pm 10\%$ ,  $V_{SS}=0\text{ V}$ ,  $T_a=-20\text{ to }+75^\circ\text{C}$ , unless otherwise noted.)

Item	Symbol	HD63B09		HD63C09		Unit	Test Condition
		Min	Typ	Max	Min		
Input High Voltage	$\overline{RES}$	$V_{IH}$	$V_{CC}-0.5$	$V_{CC}$	$V_{CC}-0.5$	$V_{CC}$	V
	EXTAL		$V_{CC}\times 0.7$	$V_{CC}$	$V_{CC}\times 0.7$	$V_{CC}$	
	Other Inputs		2.0	$V_{CC}$	2.0	$V_{CC}$	
Input Low Voltage	EXTAL	$V_{IL}$	-0.3	0.6	-0.3	0.6	V
	Other Inputs		-0.3	0.8	-0.3	0.8	
Input Leakage Current	Except EXTAL, XTAL	$I_n$	-2.5	2.5	-2.5	2.5	$\mu\text{A}$ $V_{in}=0\text{ to }V_{CC}$ , $V_{CC}=\text{max}$
Three State (Off State)	$D_0-D_7$	$I_{TSI}$	-10	10	-10	10	$\mu\text{A}$ $V_{in}=0.4\text{ to }V_{CC}$ , $V_{CC}=\text{max}$
Input Current	$A_0-A_{15}$ , $R/\overline{W}$		-10	10	-10	10	$V_{CC}=\text{max}$
Output High Voltage	$D_0-D_7$	$V_{OH}$	4.1		4.1		V $I_{LOAD}=-400\mu\text{A}$
			$V_{CC}-0.1$		$V_{CC}-0.1$		$I_{LOAD}\leq -10\mu\text{A}$
	$A_0-A_{15}$ , $R/\overline{W}$		4.1		4.1		$I_{LOAD}=-400\mu\text{A}$
	Q, E		$V_{CC}-0.1$		$V_{CC}-0.1$		$I_{LOAD}\leq -10\mu\text{A}$
	BA, BS		4.1		4.1		$I_{LOAD}=-400\mu\text{A}$
			$V_{CC}-0.1$		$V_{CC}-0.1$		$I_{LOAD}\leq -10\mu\text{A}$
Output Low Voltage		$V_{OL}$		0.5		0.5	V $I_{LOAD}=2\text{mA}$
Input Capacitance	$D_0-D_7$	$C_{in}$		15		15	$\text{pF}$ $V_{in}=0\text{V}$ , $T_a=25^\circ\text{C}$ , $f=1\text{MHz}$
	Except $D_0-D_7$			10		10	
Output Capacitance	$A_0-A_{15}$ , $R/\overline{W}$ , $C_{out}$			12		12	$\text{pF}$
	BA, BS						
Current Dissipation		$I_{CC}$		24		36	$\text{mA}$ Operating
				15		18	Sleeping

# HD6309

AC Characteristics ( $V_{CC}=5.0\text{ V} \pm 10\%$ ,  $V_{SS}=0\text{ V}$ ,  $T_a=-20\text{ to }+75^\circ\text{C}$ , unless otherwise noted.)

## Clock Timing

Item	Symbol	HD63B09			HD63C09			Unit	Test Condition
		Min	Typ	Max	Min	Typ	Max		
Frequency of Operation (Crystal External Input)	$f_{XTAL}$	2		8	2		12	MHz	Figs. 25, 26
Cycle Time	$t_{CYC}$	500		2000	333		2000	ns	
Total Up Time	$t_{UT}$	480			310			ns	
Processor Clock High	$t_{PWH}$	220		5000	140		5000	ns	
Processor Clock Low	$t_{PWL}$	210		1000	140		1000	ns	
E Rise and Fall Time	$t_{Er}$ , $t_{Ef}$			20			20	ns	
$E_{Low}$ to $Q_{High}$ Time	$t_{LVS}$	100		140	70		100	ns	
Q Clock High	$t_{PWH}$	220		1000	140		1000	ns	
Q Clock Low	$t_{PWL}$	220		5000	140		5000	ns	
Q Rise and Fall Time	$t_{Qr}$ , $t_{Qf}$			20			20	ns	
$Q_{Low}$ to $E_{Low}$ Time	$t_{QE}$	100			70			ns	

## Bus Timing

Item	Symbol	HD63B09			HD63C09			Unit	Test Condition
		Min	Typ	Max	Min	Typ	Max		
Address Delay	$t_{AD}$			110			110	ns	Figs. 25, 26
Peripheral Read Access Time ( $t_{UT}-t_{AD}-t_{OSR}=t_{ACC}$ )	$t_{ACC}$	330			160			ns	
Data Set Up Time (Read)	$t_{OSR}$	40			40			ns	
Input Data Hold Time	$t_{OHR}$	10			10			ns	
Address Hold Time	$t_{AH}$	$T_a=0\text{ to }+75^\circ\text{C}$		20		20		ns	
		$T_a=-20\text{ to }0^\circ\text{C}$		10		10			
Data Delay Time (Write)	$t_{ODW}$			110			70	ns	
Output Hold Time	$t_{OHV}$	$T_a=0\text{ to }+75^\circ\text{C}$		30		30		ns	
		$T_a=-20\text{ to }0^\circ\text{C}$		20		20			

## Processor Control Timing

Item	Symbol	HD63B09			HD63C09			Unit	Test Condition
		Min	Typ	Max	Min	Typ	Max		
MRDY Set Up Time 1	$t_{PCSM}$	110			70			ns	Figs. 3 - 7
MRDY Set Up Time 2	$t_{PCSM2}$	240			160			ns	Figs. 11, 12
Interrupts Set Up Time	$t_{PCS}$	110			70			ns	
HALT Set Up Time	$t_{PCSH}$	110			70			ns	
RES Set Up Time	$t_{PCSR}$	110			110			ns	
DMA/BREQ Set Up Time	$t_{PCSD}$	110			70			ns	
Processor Control Rise and Fall Time	$t_{PCr}$			100			100	ns	
	$t_{PCf}$								
Crystal Oscillator Start Time	$t_{RC}$	20			20			ms	

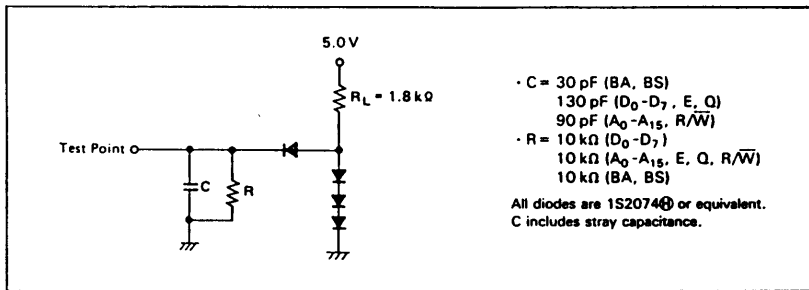

Figure 24. Bus Timing Test Load

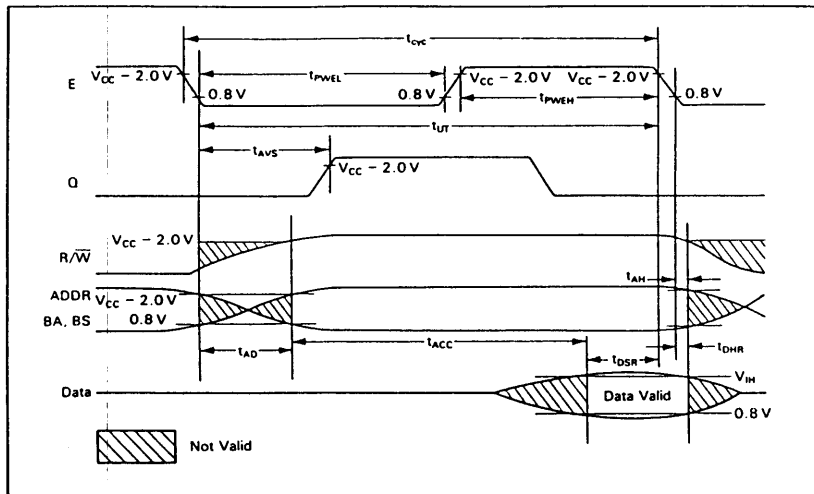

Figure 25. Read Data from Memory or Peripherals

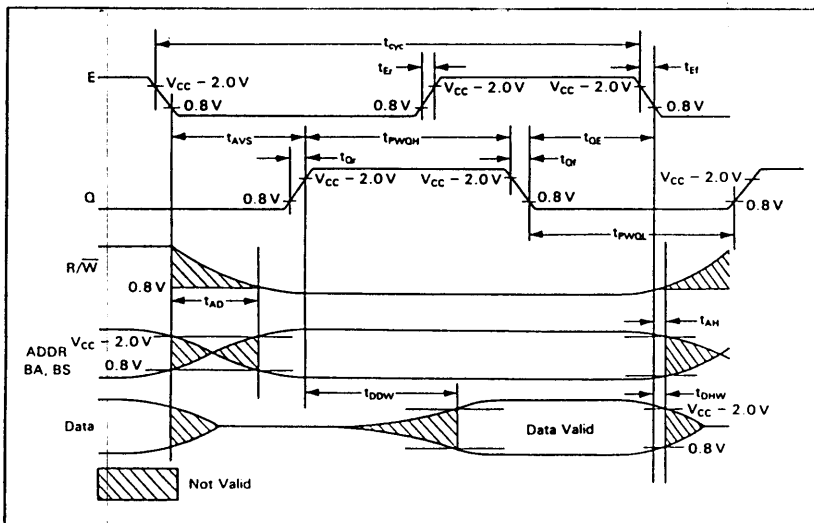

Figure 26. Write Data to Memory or Peripherals

## Package Dimensions

Unit : mm (inch)

DP-40

