

# Optocoupler, Phototransistor Output, 4 Pin SOP, Low Profile Package

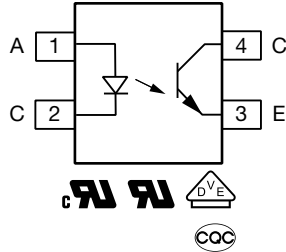

## DESCRIPTION

The VOM619A series has an infrared emitting diode, which is optically coupled to a phototransistor detector, and is incorporated in a green 4-pin small outline package.

It features a high current transfer ratio at low input current with enhanced linearity over temperature.

The coupling device is designed for signal transmission between two electrically separated circuits.

## FEATURES

- Low profile package
- High CTR at low forward current
- High collector emitter voltage,  $V_{CE0} = 80\text{ V}$
- High isolation voltage,  $V_{ISO} = 3750\text{ V}_{RMS}$
- Enhanced CTR linearity over temperature and forward current
- Operating temperature up to  $125\text{ }^{\circ}\text{C}$
- Material categorization: for definitions of compliance please see [www.vishay.com/doc?99912](http://www.vishay.com/doc?99912)



## APPLICATIONS

- DC/DC converters
- Programmable controllers
- Power supplies
- Signal transmission with galvanic and noise isolation

## AGENCY APPROVALS

(All parts are certified under base model VOM619A)

- UL
- cUL
- DIN EN 60747-5-5 (VDE 0884-5)
- CQC

ORDERING INFORMATION			
<div style="display: flex; justify-content: space-around; font-weight: bold; font-size: 1.2em;"> <span>V</span><span>O</span><span>M</span><span>6</span><span>1</span><span>9</span><span>A</span><span>-</span><span>#</span><span>X</span><span>0</span><span>0</span><span>1</span><span>T</span> </div> <div style="display: flex; justify-content: space-around; margin-top: 5px;"> <div style="border-top: 1px solid black; width: 200px; margin: 0 auto;"></div> <div style="border-top: 1px solid black; width: 40px; margin: 0 auto;"></div> <div style="border-top: 1px solid black; width: 100px; margin: 0 auto;"></div> <div style="border-top: 1px solid black; width: 40px; margin: 0 auto;"></div> </div> <p style="text-align: center; margin-top: 5px;">PART NUMBER                      CTR BIN                      PACKAGE OPTION                      TAPE AND REEL</p>			
<b>AGENCY CERTIFIED / PACKAGE</b>	<b>CTR (%)</b>		
	<b>0.5 mA</b>		
<b>UL, cUL, CQC, VDE</b>	<b>100 to 250</b>	<b>160 to 320</b>	<b>200 to 400</b>
SOP-4	VOM619A-3X001T	VOM619A-4X001T	VOM619A-9X001T

### Note

- Additional options may be possible, please contact sales office.



<b>ABSOLUTE MAXIMUM RATINGS</b> ( $T_{amb} = 25\text{ }^{\circ}\text{C}$ , unless otherwise specified)				
PARAMETER	TEST CONDITION	SYMBOL	VALUE	UNIT
<b>INPUT</b>				
Reverse voltage		$V_R$	5	V
Power dissipation		$P_{diss}$	50	mW
Forward current		$I_F$	30	mA
Surge forward current	$t_p \leq 1\text{ }\mu\text{s}$	$I_{FSM}$	1.0	A
Junction temperature		$T_J$	135	$^{\circ}\text{C}$
<b>OUTPUT</b>				
Collector emitter voltage		$V_{CEO}$	80	V
Emitter collector voltage		$V_{ECO}$	7	V
Collector current		$I_C$	30	mA
Power dissipation		$P_{diss}$	200	mW
Junction temperature		$T_J$	135	$^{\circ}\text{C}$
<b>COUPLER</b>				
Total power dissipation		$P_{tot}$	200	mW
Storage temperature range		$T_{stg}$	-55 to +125	$^{\circ}\text{C}$
Ambient temperature range		$T_{amb}$	-55 to +125	$^{\circ}\text{C}$
Soldering temperature <sup>(1)</sup>	$t = 10\text{ s}$	$T_{slid}$	260	$^{\circ}\text{C}$

**Notes**

- Stresses in excess of the absolute maximum ratings can cause permanent damage to the device. Functional operation of the device is not implied at these or any other conditions in excess of those given in the operational sections of this document. Exposure to absolute maximum ratings for extended periods of the time can adversely affect reliability.

<sup>(1)</sup> Refer to reflow profile for soldering conditions for surface mounted devices.

<b>RECOMMENDED OPERATING CONDITIONS</b> ( $T_{amb} = 25\text{ }^{\circ}\text{C}$ , unless otherwise specified)				
PARAMETER	SYMBOL	MIN.	MAX.	UNIT
Forward current	$I_F$	0.5	10	mA

<b>ELECTRICAL CHARACTERISTICS</b> ( $T_{amb} = 25\text{ }^{\circ}\text{C}$ , unless otherwise specified)						
PARAMETER	TEST CONDITION	SYMBOL	MIN.	TYP.	MAX.	UNIT
<b>INPUT</b>						
Forward voltage	$I_F = 10\text{ mA}$	$V_F$	-	-	1.6	V
Capacitance	$V_R = 0\text{ V}$ , $f = 1\text{ kHz}$	$C_O$	-	30	-	pF
Reverse current	$V_R = 5\text{ V}$	$I_R$	-	-	5	$\mu\text{A}$
<b>OUTPUT</b>						
Collector emitter dark current	$V_{CE} = 20\text{ V}$ , $I_F = 0\text{ A}$	$I_{CEO}$	-	-	200	nA
Collector emitter breakdown voltage	$I_C = 0.5\text{ mA}$	$BV_{CEO}$	80	-	-	
Emitter-Collector breakdown voltage	$I_E = 0.1\text{ mA}$	$BV_{ECO}$	7	-	-	
<b>COUPLER</b>						
Collector emitter saturation voltage	$I_C = 2.4\text{ mA}$ , $I_F = 8\text{ mA}$	$V_{CEsat}$	-	-	0.3	V
Floating capacitance	$f = 1\text{ MHz}$	$C_C$	-	0.8	-	pF

**Note**

- Minimum and maximum values are testing requirements. Typical values are characteristics of the device and are the result of engineering evaluation. Typical values are for information only and are not part of the testing requirements.

<b>CURRENT TRANSFER RATIO</b> ( $T_{amb} = 25\text{ }^{\circ}\text{C}$ , unless otherwise specified)							
PARAMETER	TEST CONDITION	PART	SYMBOL	MIN.	TYP.	MAX.	UNIT
$I_C/I_F$	$I_F = 0.5\text{ mA}$ , $V_{CE} = 5\text{ V}$	VOM619A-3	CTR	100	-	250	%
		VOM619A-4	CTR	160	-	320	%
		VOM619A-9	CTR	200	-	400	%

<b>SWITCHING CHARACTERISTICS</b> ( $T_{amb} = 25\text{ }^{\circ}\text{C}$ , unless otherwise specified)							
PARAMETER	TEST CONDITION	SYMBOL	MIN.	TYP.	MAX.	UNIT	
Rise time	$V_{CE} = 2\text{ V}$ , $I_C = 2\text{ mA}$ , $R_L = 100\text{ }\Omega$	$t_r$	-	6	18	$\mu\text{s}$	
Fall time	$V_{CE} = 2\text{ V}$ , $I_C = 2\text{ mA}$ , $R_L = 100\text{ }\Omega$	$t_f$	-	8	18	$\mu\text{s}$	

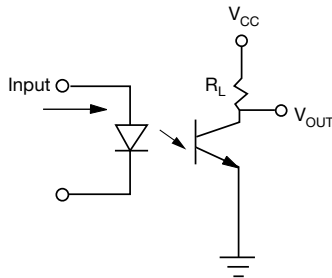
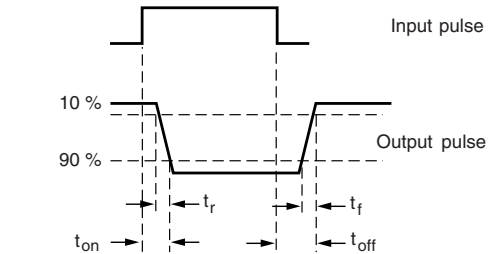

Fig. 1 - Test Circuit



isfh618a\_12

Fig. 2 - Test Circuit and Waveforms

<b>SAFETY AND INSULATION RATINGS</b>				
PARAMETER	TEST CONDITION	SYMBOL	VALUE	UNIT
Climatic classification	According to IEC 68 part 1		55 / 125 / 21	
Pollution degree	According to DIN VDE 0109		2	
Comparative tracking index	Insulation group IIIa	CTI	175	
Maximum rated withstanding isolation voltage	According to UL1577, $t = 1\text{ min}$	$V_{ISO}$	3750	$V_{RMS}$
Maximum transient isolation voltage	According to DIN EN 60747-5-5	$V_{IOTM}$	4800	$V_{peak}$
Maximum repetitive peak isolation voltage	According to DIN EN 60747-5-5	$V_{IORM}$	850	$V_{peak}$
Isolation resistance	$T_{amb} = 25\text{ }^{\circ}\text{C}$ , $V_{IO} = 500\text{ V}$	$R_{IO}$	$\geq 5 \times 10^{10}$	$\Omega$
	$T_{amb} = T_S$ , $V_{IO} = 500\text{ V}$	$R_{IO}$	$\geq 10^9$	$\Omega$
Output safety power		$P_{SO}$	150	mW
Input safety current		$I_{SI}$	130	mA
Input safety temperature		$T_S$	150	$^{\circ}\text{C}$
Creepage distance			$\geq 5$	mm
Clearance distance			$\geq 5$	mm
Insulation thickness		DTI	$\geq 0.4$	mm

**Note**

- According to DIN EN 60747-5-5 (VDE 0884). This optocoupler is suitable for safe electrical isolation only within the safety ratings. Compliance with the safety ratings shall be ensured by means of suitable protective circuits.

**TYPICAL CHARACTERISTICS** ( $T_{amb} = 25\text{ }^{\circ}\text{C}$ , unless otherwise specified)

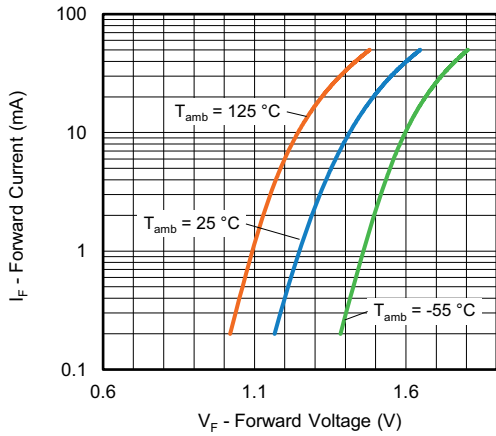

Fig. 3 - Forward Current vs. Forward Voltage

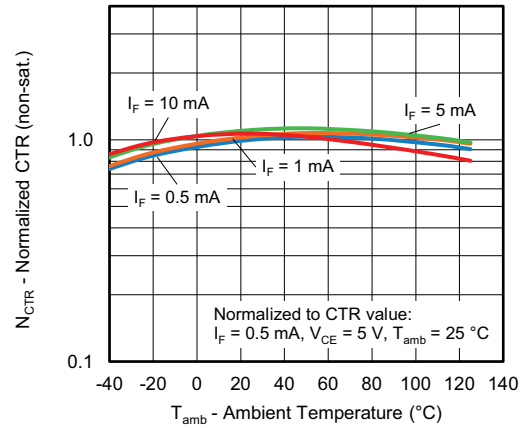

Fig. 6 - Normalized CTR vs. Ambient Temperature

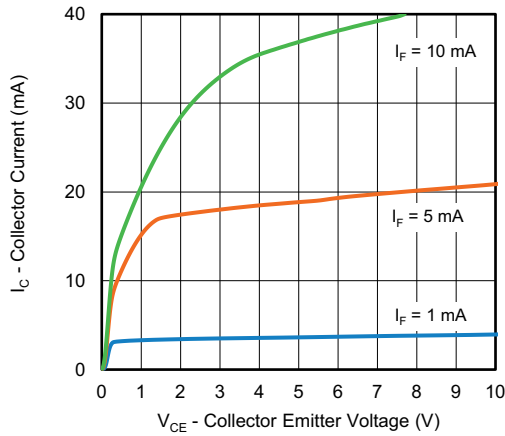

Fig. 4 - Collector Current vs. Collector Emitter Voltage (non-saturated)

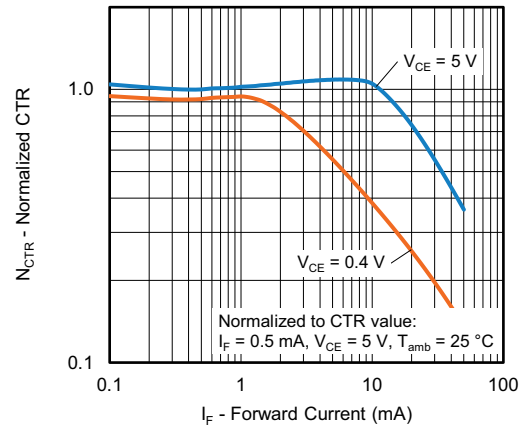

Fig. 7 - Normalized CTR vs. Forward Current

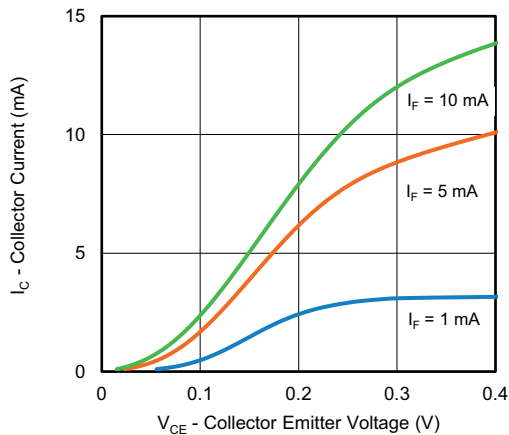

Fig. 5 - Collector Current vs. Collector Emitter Voltage (saturated)

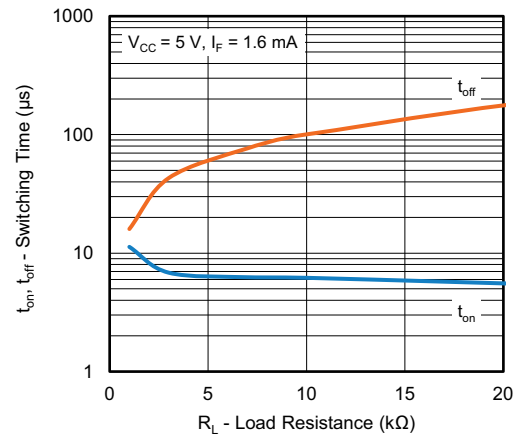

Fig. 8 - Switching Time vs. Load Resistance

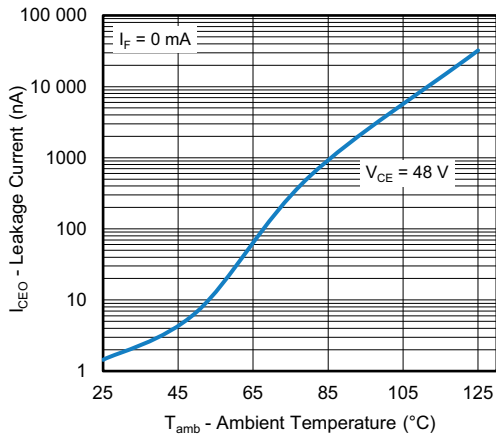
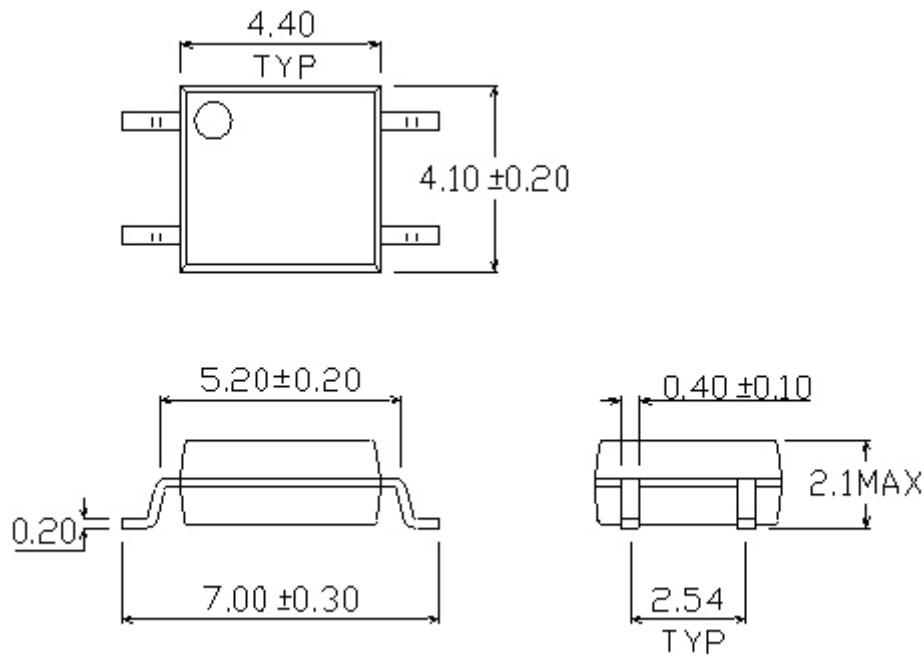
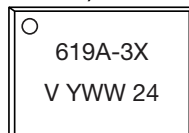

Fig. 9 - Leakage Current vs. Ambient Temperature

**PACKAGE DIMENSIONS** (in millimeters)



**PACKAGE MARKING** (example of VOM619A-3X001T)



**Notes**

- Tape and reel suffix (T) is not part of the package marking
- YWW = date code

**TAPE AND REEL DIMENSIONS** (in millimeters)

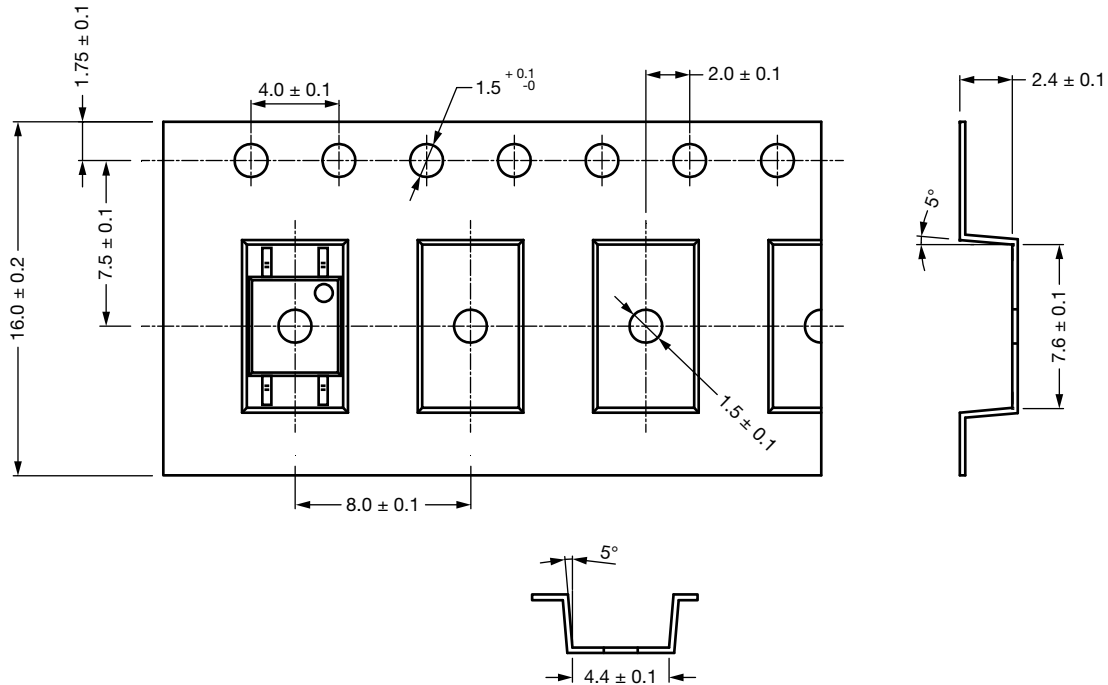
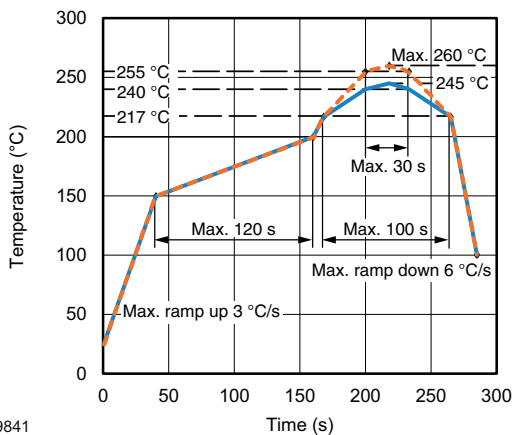

Fig. 10 - Tape and Reel Packing

TAPE AND REEL PACKING	
TYPE	UNITS/REEL
SOP-4	3500

**SOLDER PROFILE**



19841

Fig. 11 - Lead (Pb)-free Reflow Solder Profile According to J-STD-020

**HANDLING AND STORAGE CONDITIONS**

ESD level: HBM class 2

Floor life: unlimited

Conditions:  $T_{amb} < 30\text{ °C}$ ,  $RH < 85\%$

Moisture sensitivity level 1, according to J-STD-020



## **Disclaimer**

ALL PRODUCT, PRODUCT SPECIFICATIONS AND DATA ARE SUBJECT TO CHANGE WITHOUT NOTICE TO IMPROVE RELIABILITY, FUNCTION OR DESIGN OR OTHERWISE.

Vishay Intertechnology, Inc., its affiliates, agents, and employees, and all persons acting on its or their behalf (collectively, "Vishay"), disclaim any and all liability for any errors, inaccuracies or incompleteness contained in any datasheet or in any other disclosure relating to any product.

Vishay makes no warranty, representation or guarantee regarding the suitability of the products for any particular purpose or the continuing production of any product. To the maximum extent permitted by applicable law, Vishay disclaims (i) any and all liability arising out of the application or use of any product, (ii) any and all liability, including without limitation special, consequential or incidental damages, and (iii) any and all implied warranties, including warranties of fitness for particular purpose, non-infringement and merchantability.

Statements regarding the suitability of products for certain types of applications are based on Vishay's knowledge of typical requirements that are often placed on Vishay products in generic applications. Such statements are not binding statements about the suitability of products for a particular application. It is the customer's responsibility to validate that a particular product with the properties described in the product specification is suitable for use in a particular application. Parameters provided in datasheets and / or specifications may vary in different applications and performance may vary over time. All operating parameters, including typical parameters, must be validated for each customer application by the customer's technical experts. Product specifications do not expand or otherwise modify Vishay's terms and conditions of purchase, including but not limited to the warranty expressed therein.

Hyperlinks included in this datasheet may direct users to third-party websites. These links are provided as a convenience and for informational purposes only. Inclusion of these hyperlinks does not constitute an endorsement or an approval by Vishay of any of the products, services or opinions of the corporation, organization or individual associated with the third-party website. Vishay disclaims any and all liability and bears no responsibility for the accuracy, legality or content of the third-party website or for that of subsequent links.

Vishay products are not designed for use in life-saving or life-sustaining applications or any application in which the failure of the Vishay product could result in personal injury or death unless specifically qualified in writing by Vishay. Customers using or selling Vishay products not expressly indicated for use in such applications do so at their own risk. Please contact authorized Vishay personnel to obtain written terms and conditions regarding products designed for such applications.

No license, express or implied, by estoppel or otherwise, to any intellectual property rights is granted by this document or by any conduct of Vishay. Product names and markings noted herein may be trademarks of their respective owners.