

THIS DRAWING IS UNPUBLISHED. RELEASED FOR PUBLICATION  
 © COPYRIGHT BY TYCO ELECTRONICS CORPORATION. ALL RIGHTS RESERVED.

LOC	DIST	REVISIONS					
FT	0	P	LTR	DESCRIPTION	DATE	DWN	APVD
		AU		REVISED PER 0G3B-0288-04	4/5/04	SS	GS
		AU1		REVISED PER ECO-10-000443	13JAN10	KK	HMR

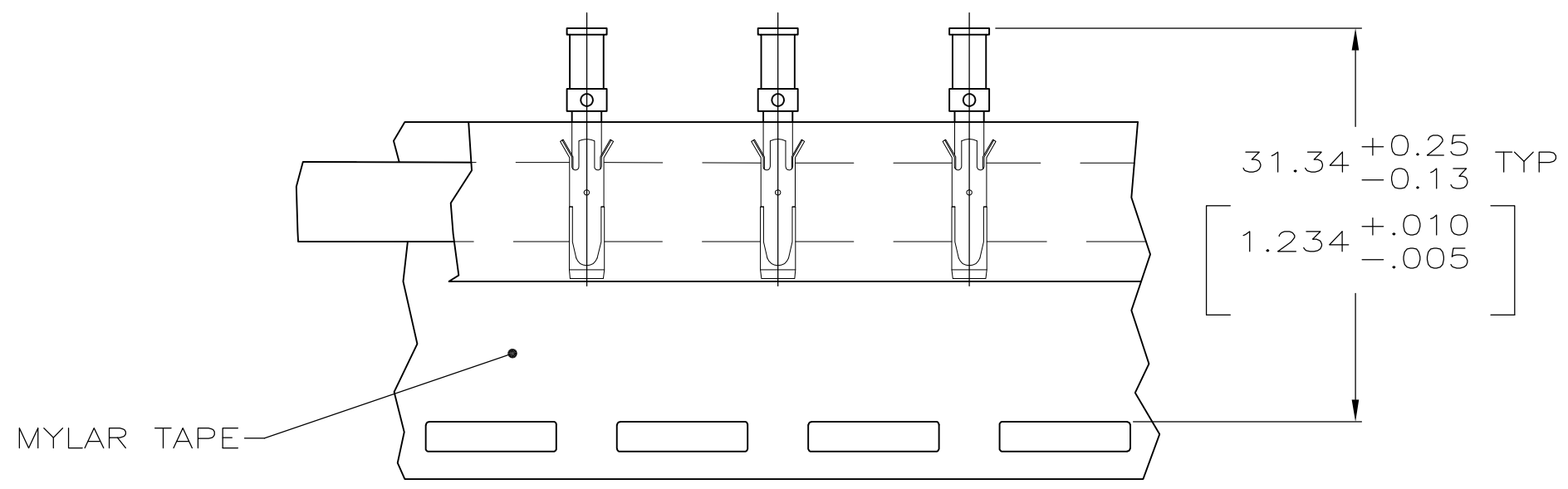
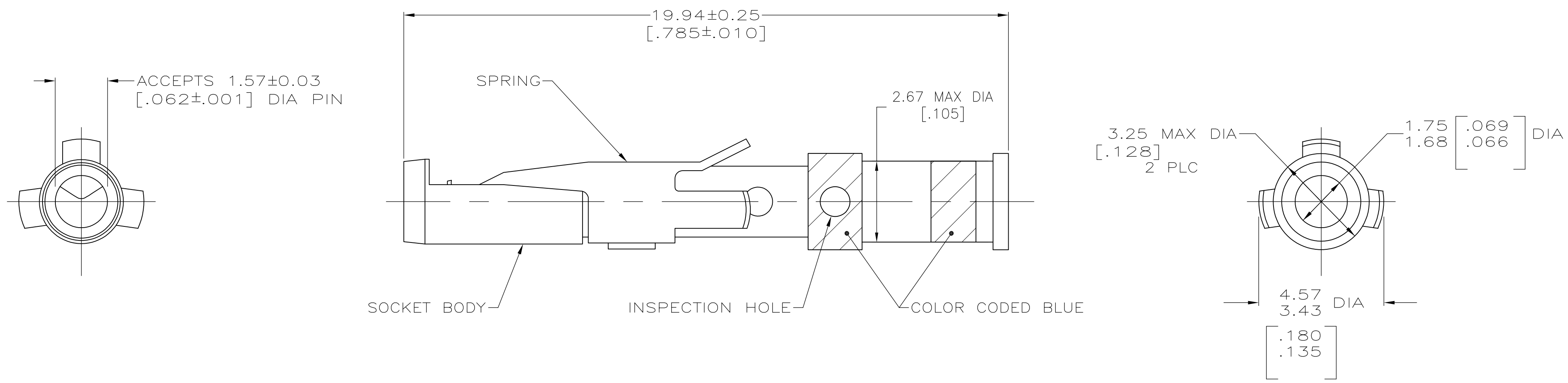

TAPE MTG DETAIL  
SCALE 2:1

- ① 0.76µm [.000030] MIN GOLD OVER 1.27µm [.000050] MIN NICKEL.
- ② 1.27µm [.000050] MIN GOLD OVER 1.27µm [.000050] MIN NICKEL.
- ③ WHEN ORDERING CONTACT ASSEMBLY ON TAPE, ORDER BY THE TAPE NUMBER PLUS THE PACKAGING CODE AS FOLLOWS:
  1. FOR USE WITH AMP TAPETRONIC, PNEUMATIC TOOL—
    - A. 1000 PARTS TO A BOX ADD PACKAGING CODE: 1MBOX
  2. FOR USE WITH 4/8 INDENT STRIPPER CRIMPER—
    - A. 1000 PARTS TO A REEL ADD PACKAGING CODE: 1MREEL
    - B. 5000 PARTS TO A REEL ADD PACKAGING CODE: 5MREEL
- ④ NO COLOR CODING.
- ⑤ PRELIMINARY PART NUMBER.
- ⑥ OBSOLETE PARTS: OBSOLETE CIS STREAMLINING PER D.RENAUD/D.SINISI

PACKAGING TYPE	SOCKET BODY FINISH	PART NO.
STANDARD	①	1-200333-9
SMALL PACK	①	1-200333-8
STANDARD	②	1-200333-4
TAPE MTG (SEE DETAIL) ③	①	200333-8
STANDARD	①	200333-1

THIS DRAWING IS A CONTROLLED DOCUMENT.		DWN D.GELTZ 04/05/93	Tyco Electronics Corporation Harrisburg, Pa 17105-3608	
DIMENSIONS: INCHES		CHK R.STONE 4-26-93	NAME CONTACT ASSEMBLY, SOCKET, #16, TYPE II	
TOLERANCES UNLESS OTHERWISE SPECIFIED: 0 PLC ± - 1 PLC ± - 2 PLC ± - 3 PLC ± - 4 PLC ± - ANGLES ± -		APVD -	PRODUCT SPEC -	
MATERIAL SOCKET BODY: COPPER ALLOY SPRING: STAINLESS STEEL		FINISH SOCKET BODY: SEE TABLE	APPLICATION SPEC -	WEIGHT -
		SIZE A2	CAGE CODE 00779	DRAWING NO C=200333
CUSTOMER DRAWING		SCALE 10:1	SHEET 1 OF 1	REV AU1