

USB-Blaster Download Cable User Guide



Subscribe



Send Feedback

UG-USB81204
2015.05.04

101 Innovation Drive
San Jose, CA 95134
www.altera.com



Contents

Introduction to USB-Blaster Download Cable.....	1-1
USB-Blaster Revision.....	1-1
Supported Devices and Host Systems.....	1-1
Specifications for USB-Blaster Download Cable.....	2-1
Block Diagram and Dimension.....	2-1
Cable-to-Board Connection.....	2-2
Pin Description.....	2-2
Operating Conditions.....	2-3
Power Requirements.....	2-5
RoHS Compliance.....	2-6
Using the USB-Blaster Download Cable.....	3-1
Installing the USB-Blaster Driver on Windows.....	3-1
Installing the USB-Blaster Driver on Linux.....	3-1
Installing on Red Hat Enterprise 4 or Earlier Versions.....	3-2
Installing on Red Hat Enterprise 5.....	3-2
Setting up the USB-Blaster Hardware in the Quartus II Software.....	3-2
Connecting the USB-Blaster Download Cable to the Board.....	3-3
Revision History for USB-Blaster Download Cable User Guide.....	4-1

Introduction to USB-Blaster Download Cable

1

2015.05.04

UG-USB81204



Subscribe



Send Feedback

The USB-Blaster™ download cable interfaces a USB port on a host computer to an Altera® FPGA mounted on a printed circuit board. The cable sends configuration data from the host computer to a standard 10-pin header connected to the FPGA. You can use the USB-Blaster download cable to iteratively download configuration data to a system during prototyping or to program data into the system during production.

USB-Blaster Revision

Table 1-1: USB-Blaster Revision

Revision	Indicator	Description	RoHS Compliant
Rev. A	Ribbon cable. No revision marking on the casing.	10-pin female connector that is connected to the USB-Blaster through a ribbon cable.	No
Rev. B	"Rev. B" on the casing.	10-pin female connector that is connected to the USB-Blaster through a flexible PCB cable.	No
Rev. C	"Rev. C" on the casing.	10-pin female connector that is connected to the USB-Blaster through a flexible PCB cable.	Yes

Supported Devices and Host Systems

You can use the USB-Blaster download cable with supported Altera FPGAs, serial configuration devices, and host systems.

© 2015 Altera Corporation. All rights reserved. ALTERA, ARRIA, CYCLONE, ENPIRION, MAX, MEGACORE, NIOS, QUARTUS and STRATIX words and logos are trademarks of Altera Corporation and registered in the U.S. Patent and Trademark Office and in other countries. All other words and logos identified as trademarks or service marks are the property of their respective holders as described at www.altera.com/common/legal.html. Altera warrants performance of its semiconductor products to current specifications in accordance with Altera's standard warranty, but reserves the right to make changes to any products and services at any time without notice. Altera assumes no responsibility or liability arising out of the application or use of any information, product, or service described herein except as expressly agreed to in writing by Altera. Altera customers are advised to obtain the latest version of device specifications before relying on any published information and before placing orders for products or services.

ISO
9001:2008
Registered



Table 1-2: Supported Devices and Host Systems

FPGA	Serial Configuration Device	Host System
Stratix® series	EPCS devices	Windows
Arria® series	EPCQ devices	Linux
Cyclone® series	EPCQ-L devices	
MAX® series		

Specifications for USB-Blaster Download Cable

2

2015.05.04

UG-USB81204



Subscribe



Send Feedback

The USB-Blaster download cable has a universal USB connector that plugs into the PC USB port, and a female connector that plugs into a male header on the device board. This section shows the hardware components, their dimensions, and lists the pins, operating conditions and power requirements.

Block Diagram and Dimension

Figure 2-1: Block Diagram of the USB-Blaster Download Cable

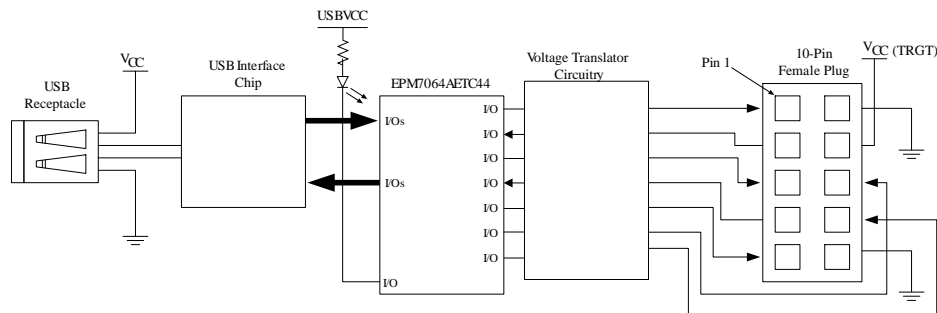
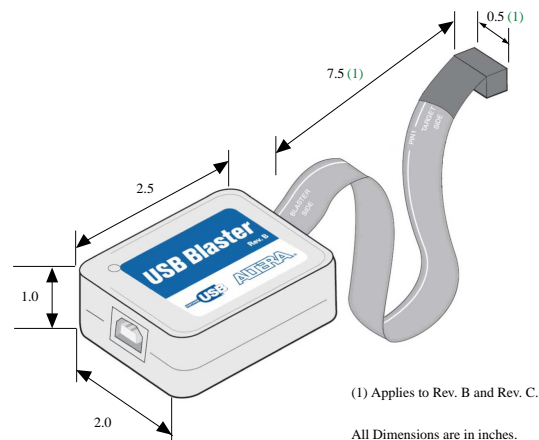

Figure 2-2: Dimension of the USB-Blaster Download Cable



© 2015 Altera Corporation. All rights reserved. ALTERA, ARRIA, CYCLONE, ENPIRION, MAX, MEGACORE, NIOS, QUARTUS and STRATIX words and logos are trademarks of Altera Corporation and registered in the U.S. Patent and Trademark Office and in other countries. All other words and logos identified as trademarks or service marks are the property of their respective holders as described at www.altera.com/common/legal.html. Altera warrants performance of its semiconductor products to current specifications in accordance with Altera's standard warranty, but reserves the right to make changes to any products and services at any time without notice. Altera assumes no responsibility or liability arising out of the application or use of any information, product, or service described herein except as expressly agreed to in writing by Altera. Altera customers are advised to obtain the latest version of device specifications before relying on any published information and before placing orders for products or services.

ISO
9001:2008
Registered



Cable-to-Board Connection

The USB-Blaster has a 10-pin female connector, which plugs into a 10-pin male header on the device board. The male header consists of two rows of five pins, which are connected to the programming or configuration pins of the device.

A 10-pin surface mount header can be used for the JTAG, AS, or PS download cable. However, Altera recommends using a through-hole connector because of the repeated insertion and removal force needed.

Figure 2-3: Connectors and Dimensions

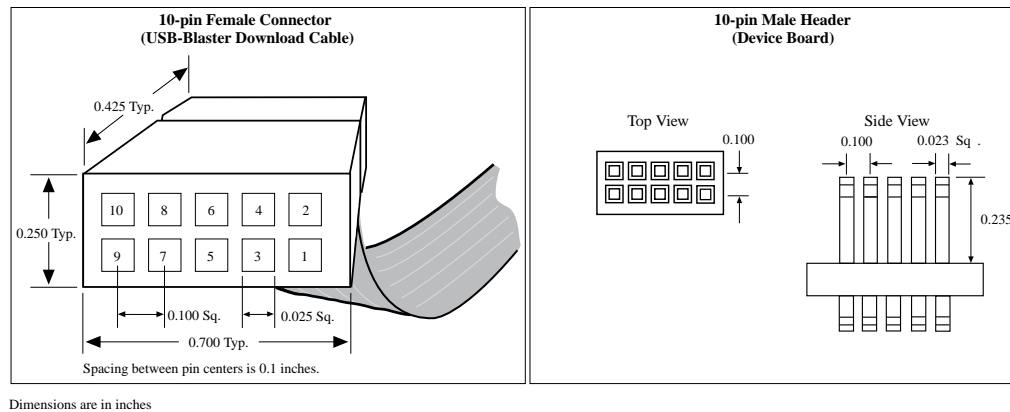

Pin Description

The following table lists the pins of the USB-Blaster female plug and describes their functions in the JTAG, active serial and passive serial modes.

Table 2-1: Signal Names of the USB-Blaster Female Plug

Pin	AS Mode		PS Mode		JTAG Mode	
	Signal Name	Description	Signal Name	Description	Signal Name	Description
1	DCLK	Clock signal.	DCLK	Clock signal.	TCK	Clock signal.
2	GND	Signal ground.	GND	Signal ground.	GND	Signal ground.
3	CONF_DONE	Configuration done.	CONF_DONE	Configuration done.	TDO	Data from device.
4	V _{CC(TRGT)}	Target power supplied by the device board.	V _{CC(TRGT)}	Target power supplied by the device board.	V _{CC(TRGT)}	Target power supplied by the device board.
5	nCONFIG	Configuration control.	nCONFIG	Configuration control.	TMS	JTAG state machine control.
6	nCE	Cyclone chip enable.	—	—	PROC_RST	Active-low signal for hard processor reset.

Pin	AS Mode		PS Mode		JTAG Mode	
	Signal Name	Description	Signal Name	Description	Signal Name	Description
7	DATAOUT	Active serial data out.	nSTATUS	Configuration status.	—	—
8	nCS	Serial configuration device chip select.	—	—	—	—
9	ASDI	Active serial data in.	DATA0	Data to device.	TDI	Data to device.
10	GND	Signal ground.	GND	Signal ground.	GND	Signal ground.

Operating Conditions

Use the provided maximum ratings, recommended operating conditions and DC operating conditions to ensure the correct usage of the USB-Blaster download cable.

Table 2-2: Absolute Maximum Ratings

Symbol	Parameter	Conditions	Min	Max	Unit
$V_{CC(TRGT)}$	Target supply voltage	With respect to ground	-0.3	5.5	V
$V_{CC(USB)}$	USB supply voltage	With respect to ground	-0.5	6.0	V
I_I	Input current	TDO or dataout	-10.0	10.0	mA
I_o	Output current for Rev. A or Rev. B cable	TCK, TMS, TDI, nCS, nCE	-20.0	20.0	mA
	Output current for Rev. C cable		-50.0	50.0	mA

Table 2-3: Recommended Operating Conditions

Symbol	Parameter	Conditions	Min	Max	Unit
$V_{CC(TRGT)}$	Target supply voltage, 5.0-V operation	—	4.75	5.25	V
	Target supply voltage, 3.3-V operation	—	3.0	3.6	V
	Target supply voltage, 2.5-V operation	—	2.375	2.625	mA
	Target supply voltage, 1.8-V operation	—	1.71	1.89	mA
	Target supply voltage, 1.5-V operation	—	1.43	1.57	mA

Table 2-4: DC Operating Conditions for USB-Blaster Rev. A and B

Symbol	Parameter	Conditions	Min	Max	Unit
V_{IH}	High-level input voltage	—	$V_{CC(TRGT)} - 0.2$	—	V
V_{IL}	Low-level input voltage	—	—	0.15	V
V_{OH}	5.0-V high-level output voltage	$V_{CC(TRGT)} = 4.5\text{ V}, I_{OH} = 1\text{ mA}$	4.4	—	V
	3.3-V high-level output voltage	$V_{CC(TRGT)} = 3.0\text{ V}, I_{OH} = 1\text{ mA}$	2.9	—	V
	2.5-V high-level output voltage	$V_{CC(TRGT)} = 2.375\text{ V}, I_{OH} = 1\text{ mA}$	2.275	—	V
	1.8-V high-level output voltage	$V_{CC(TRGT)} = 1.71\text{ V}, I_{OH} = 1\text{ mA}$	1.61	—	V
	1.5-V high-level output voltage	$V_{CC(TRGT)} = 1.43\text{ V}, I_{OH} = 1\text{ mA}$	1.33	—	V
V_{OL}	5.0-V low-level output voltage	$V_{CC(TRGT)} = 5.5\text{ V}, I_{OL} = 1\text{ mA}$	—	0.125	V
	3.3-V low-level output voltage	$V_{CC(TRGT)} = 3.6\text{ V}, I_{OL} = 1\text{ mA}$	—	0.125	V
	2.5-V low-level output voltage	$V_{CC(TRGT)} = 2.625\text{ V}, I_{OL} = 1\text{ mA}$	—	0.125	V
	1.8-V low-level output voltage	$V_{CC(TRGT)} = 1.89\text{ V}, I_{OL} = 1\text{ mA}$	—	0.125	V
	1.5-V low-level output voltage	$V_{CC(TRGT)} = 1.57\text{ V}, I_{OL} = 1\text{ mA}$	—	0.125	V
$I_{CC(TRGT)}$	Operating current (No Load)	Typical $I_{CC(TRGT)} = 16\text{ uA}$	—	100	uA

Table 2-5: DC Operating Conditions for USB-Blaster Rev. C

Symbol	Parameter	Conditions	Min	Max	Unit
V_{IH}	High-level input voltage	$V_{CC(TRGT)} \geq 2.0\text{ V}$	2.0	—	V
		$V_{CC(TRGT)} < 2.0\text{ V}$	$V_{CC(TRGT)}$	—	V
V_{IL}	Low-level input voltage	$V_{CC(TRGT)} \geq 2.0\text{ V}$	—	0.8	V
		$V_{CC(TRGT)} < 2.0\text{ V}$	—	0	V

Symbol	Parameter	Conditions	Min	Max	Unit
V_{OH}	5.0-V high-level output voltage	$V_{CC(TRGT)} = 4.5\text{ V}, I_{OH} = -10\text{ mA}$	3.8	—	V
	3.3-V high-level output voltage	$V_{CC(TRGT)} = 3.0\text{ V}, I_{OH} = -8\text{ mA}$	2.3	—	V
	2.5-V high-level output voltage	$V_{CC(TRGT)} = 2.375\text{ V}, I_{OH} = -6\text{ mA}$	1.8	—	V
	1.8-V high-level output voltage	$V_{CC(TRGT)} = 1.71\text{ V}, I_{OH} = -4\text{ mA}$	1.2	—	V
V_{OL}	5.0-V high-level output voltage	$V_{CC(TRGT)} = 5.5\text{ V}, I_{OL} = 10\text{ mA}$	—	0.8	
	3.3-V high-level output voltage	$V_{CC(TRGT)} = 3.6\text{ V}, I_{OL} = 8\text{ mA}$	—	0.7	
	2.5-V high-level output voltage	$V_{CC(TRGT)} = 2.625\text{ V}, I_{OL} = 6\text{ mA}$	—	0.6	
	1.8-V high-level output voltage	$V_{CC(TRGT)} = 1.89\text{ V}, I_{OL} = 4\text{ mA}$	—	0.5	
$I_{CC(TRGT)}$	Operating current (No Load)	Typical $I_{CC(TRGT)} = 16\text{ uA}$	—	100	uA

Power Requirements

The USB-Blaster $V_{CC(TRGT)}$ pin must be connected to a specific voltage for the device being programmed. Connect pull-up resistors to the same power supply as the USB-Blaster $V_{CC(TRGT)}$.

Table 2-6: $V_{CC(TRGT)}$ Power Requirements

Device Family	Voltage Required
FPGAs	
Stratix V, Stratix IV, and Stratix III	As specified by V_{CCPGM} or V_{CCPD} .
Stratix II, Stratix II GX, and Stratix GX	As specified by V_{CCSEL} .
Arria 10	As specified by V_{CCPGM} or V_{CCIO} .
Arria V	As specified by V_{CCPD} .
Arria II GX	As specified by V_{CCPD} or V_{CCIO} of Bank 8C
Arria GX	As specified by V_{CCSEL} .
Cyclone V	As specified by V_{CCPGM} or V_{CCPD} .
Cyclone IV	As specified by V_{CCA} or V_{CCIO} .
Cyclone III	As specified by V_{CCA} or V_{CCIO} .
Max 10	As specified by V_{CCIO} .

Device Family	Voltage Required
Configuration Devices	
EPCS	3.3 V
EPCQ	3.3 V
EPCQ-L	1.8 V

RoHS Compliance

Table 2-7: Hazardous Substances and Concentration

A value of 0 indicates that the concentration of the hazardous substance in all homogeneous materials in the parts is below the relevant threshold as specified by the SJ/T11363-2006 standard.

Part Name	Lead (Pb)	Cadmium (Cd)	Hexavalent Chromium (Cr6+)	Mercury (Hg)	Polybrominated Biphenyls (PBB)	Polybrominated Diphenyl Ethers (PBB)
Electronic components	0	0	0	0	0	0
Populated circuit board	0	0	0	0	0	0
Manufacturing process	0	0	0	0	0	0
Packing	0	0	0	0	0	0

2015.05.04

UG-USB81204



Subscribe



Send Feedback

To start using the USB-Blaster download cable, you must install the drivers on your system and set up the hardware in the Quartus II software. Altera recommends that you use the latest version of the Quartus II software.

To program or configure the device, connect the host system to the device board using the USB-Blaster download cable and initiate the programming or configuration using the Quartus II Programmer. You can also use the cable with the Quartus II SignalTap[®] II Logic Analyzer for logic analysis.

Installing the USB-Blaster Driver on Windows

1. Locate the USB-Blaster driver in \<Quartus II system directory>\drivers\usb-blaster.
If the driver is not in your directory, download the driver from www.altera.com/support/software/drivers.
2. Connect the USB-Blaster download cable to your PC.
3. Open **Device Manager**. In the **Other devices** tab, select and right click **USB-Blaster**. Then, click **Update Driver Software**.
4. Click **Browse**. Browse to \<Quartus II system directory>\drivers\usb-blaster and click **Next**.
The Windows security warning is displayed.
5. Click **Install** to begin installing the driver.
6. Click **Finish** when the driver is installed.
7. Restart your system.

Related Information

<https://www.altera.com/support/support-resources/download/drivers/dri-index.html>

Installing the USB-Blaster Driver on Linux

The Quartus II software uses the USB drivers (usbfs) provided by Red Hat Linux to access the USB-Blaster download cable. You need system administration (root) privileges to configure the drivers. You must also change the permission on the ports before using the USB-Blaster download cable to program devices.

Related Information

<https://www.altera.com/support/support-resources/download/drivers/dri-index.html>

© 2015 Altera Corporation. All rights reserved. ALTERA, ARRIA, CYCLONE, ENPIRION, MAX, MEGACORE, NIOS, QUARTUS and STRATIX words and logos are trademarks of Altera Corporation and registered in the U.S. Patent and Trademark Office and in other countries. All other words and logos identified as trademarks or service marks are the property of their respective holders as described at www.altera.com/common/legal.html. Altera warrants performance of its semiconductor products to current specifications in accordance with Altera's standard warranty, but reserves the right to make changes to any products and services at any time without notice. Altera assumes no responsibility or liability arising out of the application or use of any information, product, or service described herein except as expressly agreed to in writing by Altera. Altera customers are advised to obtain the latest version of device specifications before relying on any published information and before placing orders for products or services.

ISO
9001:2008
Registered

Installing on Red Hat Enterprise 4 or Earlier Versions

1. Add the following lines to the `/etc/hotplug/usb.usermap` file.

```
#
# Altera USB-Blaster
#
usbblaster 0x03 0x09fb 0x6001 0x0 0x0 0x0 0x0 0x0 0x0 0x0 0x0 0x0
usbblaster 0x03 0x09fb 0x6002 0x0 0x0 0x0 0x0 0x0 0x0 0x0 0x0 0x0
usbblaster 0x03 0x09fb 0x6003 0x0 0x0 0x0 0x0 0x0 0x0 0x0 0x0 0x0
```

2. Create a file named `/etc/hotplug/usb/usbblaster` and add the following lines to it.

```
#!/bin/sh
# USB-Blaster hotplug script
# Allow any user to access the cable
chmod 666 $DEVICE
```

3. Make the file executable.
4. Complete your installation by setting up the programming hardware in the Quartus II software as described in the following section.

Installing on Red Hat Enterprise 5

1. Create a file named `/etc/udev/rules.d/51-usbblaster.rules` and add the following lines to it. Ensure that all code after `#USB-Blaster` must be in one line.

```
# USB-Blaster
BUS=="usb", SYSFS{idVendor}=="09fb", SYSFS{idProduct}=="6001", MODE="0666",
PROGRAM="/bin/sh -c 'K=%k; K=${K#usbdev}; printf /proc/bus/usb/%03i/%03i ${K%%%.*} ${K#*}.'", RUN+="/bin/chmod 0666 %c"
```

2. Complete your installation by setting up the programming hardware in the Quartus II software.

Setting up the USB-Blaster Hardware in the Quartus II Software

1. Launch the Quartus II software.
2. Click **Tools > Programmer**.
3. Click **Hardware Setup**.

Figure 3-1: Hardware Setup Dialog Box

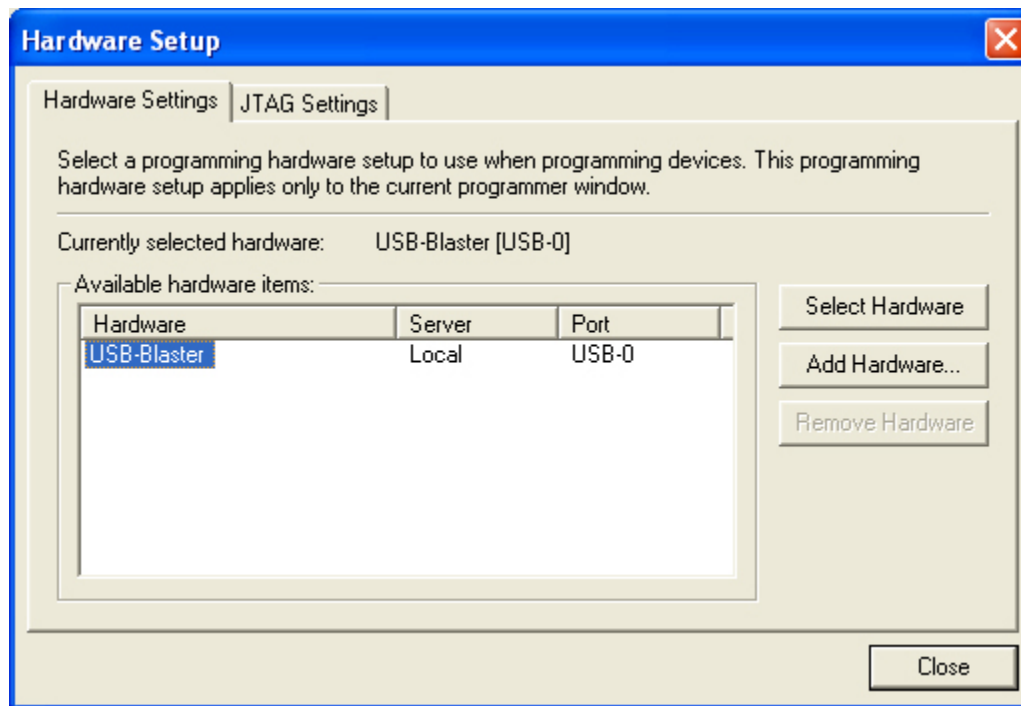

The **Hardware Settings** tab of the **Hardware Setup** dialog box is displayed.

4. From the **Currently selected hardware** drop-down list, select **USB-Blaster [USB-0]**.
5. Click **Close** to close the **Hardware Setup** dialog box.
6. In the **Programmer** window, select the desired programming mode from the **Mode** drop-down list.

Table 3-1: Programming Modes

Mode	Description
Joint Test Action Group (JTAG)	Programs or configures all supported Altera devices except EPCS, EPCQ, and EPCQ-L devices.
In-Socket Programming	USB-Blaster does not support this programming mode.
Passive Serial	Configures all supported Altera devices except EPCS, EPCQ, and EPCQ-L devices.
Active Serial Programming	Programs a single EPCS, EPCQ, or EPCQ-L device.

Connecting the USB-Blaster Download Cable to the Board

1. Disconnect the power cable from the device board.
2. Connect the USB-Blaster download cable to your PC.
3. Plug the USB-Blaster download cable into the 10-pin header on the device board.

Figure 3-2: Connection to the Device Board

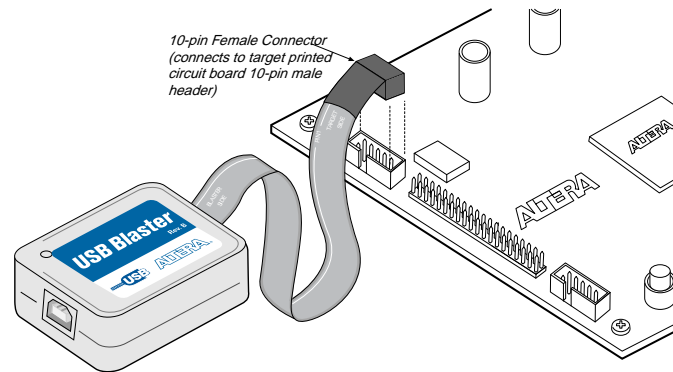

4. Connect the power cable to the device board.
The **Found New Hardware** wizard may open and prompt you to install a new hardware driver. Close the wizard and follow the steps provided in subsequent sections to install the hardware driver.
5. To disconnect the USB Blaster download cable from the device board, follow these steps to ensure that the cable is not damaged.
 - a. Remove power from the device board.
 - b. Unplug the USB-Blaster download cable from the board.
 - c. Unplug the USB-Blaster download cable from your PC.

Revision History for USB-Blaster Download Cable User Guide

4

2015.05.04

UG-USB81204



Subscribe



Send Feedback

Date	Version	Changes
May 2015	2015.05.04	<ul style="list-style-type: none"> Updated the document organization. Added new devices in the following sections: Supported Devices and Host Systems and Power Requirements. Updated the procedure on driver installation for Windows. Revised the pin width of the female plug.
April 2009	2.5	<ul style="list-style-type: none"> Updated “Supported Devices” section. Updated “Software Requirements”. Deleted handnote in “Installing the USB-Blaster Driver on Windows Vista Systems”. Updated Table 2–1. Added a handnote in “Circuit Board Header Connection”. Updated Table 2–5.
April 2008	2.4	<ul style="list-style-type: none"> Added “Statement of China-RoHS Compliance”. Added Table 2–8. Added “Installing the USB-Blaster Driver on Windows Vista Systems”.
May 2007	2.3	<ul style="list-style-type: none"> Updated “Introduction”. Added warning note about USB-Blaster cable in “Hardware Setup” section. Added information on Linux setup in “Installing the USB-Blaster Driver on Linux” section. Added feetpara note on driver information just before the “Setting Up the USB-Blaster Hardware in the Quartus II Software” section. Updated USB-Blaster installation procedure for QII 6.1 (32-bit or 64-bit) in “Installing the USB-Blaster Driver on Windows 2000 and Windows XP Systems” section.

© 2015 Altera Corporation. All rights reserved. ALTERA, ARRIA, CYCLONE, ENPIRION, MAX, MEGACORE, NIOS, QUARTUS and STRATIX words and logos are trademarks of Altera Corporation and registered in the U.S. Patent and Trademark Office and in other countries. All other words and logos identified as trademarks or service marks are the property of their respective holders as described at www.altera.com/common/legal.html. Altera warrants performance of its semiconductor products to current specifications in accordance with Altera's standard warranty, but reserves the right to make changes to any products and services at any time without notice. Altera assumes no responsibility or liability arising out of the application or use of any information, product, or service described herein except as expressly agreed to in writing by Altera. Altera customers are advised to obtain the latest version of device specifications before relying on any published information and before placing orders for products or services.

ISO
9001:2008
Registered



Date	Version	Changes
March 2007	2.2	<ul style="list-style-type: none">Update to “Installing the USB-Blaster Driver on Windows 2000 and Windows XP Systems” section.
July 2006	2.1	Minor update to Chapter 2, USB-Blaster Specifications.
June 2006	2.0	<ul style="list-style-type: none">Updated Figure 2-1, Table 2-1, and Table 2-7.Added Table 2-6.
December 2004	1.2	Update to conditions in Table 2-2.
November 2004	1.1	Minor update.
July 2004	1.0	Initial release.