

# Spherical T2 8,000 hours

Compact Fluorescent Lamps Integrated  
5W and 7W

## Product information

The T2 8,000 hours spherical lamps offer traditional incandescent shape and sizes, long life and elegant light. Suitable for multi-arm fixtures or anywhere the bulb is visible, GE Lighting's Decor CFL range is an ideal and eco-friendly solution.

## Features

Compact Fluorescent Lamps (CFL) have an important role to play in the future of lighting, helping to protect the environment by using less energy and creating less CO<sub>2</sub> emissions. In addition, CFL lamps contribute to the reduction of maintenance costs, ensuring that financial benefits are enjoyed alongside environmental benefits.

There are a variety of performance advantages afforded by GE Lighting CFL lamps. They use almost 80% less energy and last eight times longer than their incandescent predecessors, are rated Energy Class 'A' and offer high quality light.

With continuing technological advancements and miniaturisation, today's T2 CFL lamps are even smaller than the incandescent lamps that they replace to ensure that they are discreet – yet high performing.

- 8,000 hours life
- T2 tube inside, small sizes
- 'A' energy class



## Application areas

Spherical T2 8,000 hours lamps are recommended for general indoor applications such as:

- Home lighting
- Retail lighting
- Hotels
- Restaurants
- Corridors, hallways

## Product range

Spherical T2 8,000 hours lamps are available in a range of:

- 5 and 7 wattages
- E14, E27, B22 caps
- Warm (2700K) colour
- Box and blister packs



# Compliance

## Standards

- IEC 60061-1: Lamp caps and holders together with gauges for the control of interchangeability and safety
- IEC or EN 60969: Self ballasted lamps for general lighting services – performance requirements
- IEC or EN 60968: Self-ballasted lamps for general lighting services – safety requirements
- CIE S 009/E:2002: Photobiological safety of lamps and lamp systems
- EN 61547: Requirement for general lighting purposes – EMC immunity requirement
- EN 55015 or CISPR 15: Limits and methods of measurement of radio disturbance characteristics of electrical lighting and similar equipment
- EN 61000-3-2: Electromagnetic compatibility (EMC) – Part 3-2: Limits – limits for harmonic current emissions (equipment input current up to and including 16A per phase)
- EN 61000-3-3: Electromagnetic compatibility (EMC) – Part 3-3: Limits – limitation of voltage fluctuations and flicker in low-voltage supply systems for equipment with rated current up to 16A
- EN 62493 Assessment of lighting equipment related to human exposure to electromagnetic fields

## European Directives:

- CE mark: 93/68/EEC; LVD: 2006/95/EC; EMC: 2004/108/EC, Ecodesign 2005/32/EC, ROHS 2011/65/EU
- Energy Labelling: Directive 2010/30/EU, 874/2012/EU energy labelling of electrical lamps and luminaires
- RoHS: Directive 2011/65/EU on Restrictions of the use of certain Hazardous Substances (RoHS)
- WEEE: Directive 2012/19/EU on Waste Electrical and Electronic Equipment (WEEE)
- REACH: Directive 2006/1907/EC on Registration, Evaluation, Authorisation and Restriction of Chemicals (REACH)
- ErP ecodesign: Directive 2005/32/EC, 2009/244/EC ecodesign requirements (of Energy-related Products) for non-directional household lamps

## Basic data

Rated* Wattage [W]	Volts [V]	Cap	Product Description	Product Code GE Box pack	Product Code GE Blister pack	Rated* Lumen [lm]	CCT [K]	CRI [Ra]	Rated* Life [h]	Length [mm]	Diameter [mm]	Pack Qty	EuP Inca Watt Equivalent	EEC	Energy consumption [kWh/1000h]
5	220-240	E14	FLE5SPH/T2/827/E14	33789		220	2700	82	8000	96	45	8	24	A	5
5	220-240	B22	FLE5SPH/T2/827/B22	33790		220	2700	82	8000	92	45	8	24	A	5
7	220-240	E14	FLE7SPH/T2/827/E14	33928	33909	320	2700	82	8000	96	45	8 (box)/ 10 (blister)	32	A	7
7	220-240	E27	FLE7SPH/T2/827/E27	33922		320	2700	82	8000	93	45	8	32	A	7
7	220-240	B22	FLE7SPH/T2/827/B22	33932		320	2700	82	8000	92	45	8	32	A	7

\*Rated wattage, life and lumen are equivalent to nominal values, which are indicated on product packaging

## Survival rate and lumen maintenance

Life Expectancy and Lumen Maintenance **Globe T3**

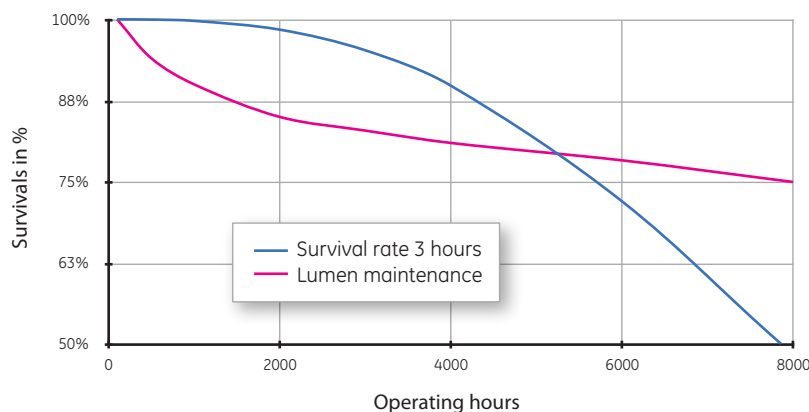

Test condition: 50Hz 230V 3 hours cycling - according to IEC60969

Hours	Survival rate 3 hours	Lumen maintenance
100	1.00	1.00
2,000	0.98	0.85
4,000	0.90	0.81
6,000	0.72	0.78
8,000	0.50	0.75

## Dimensions

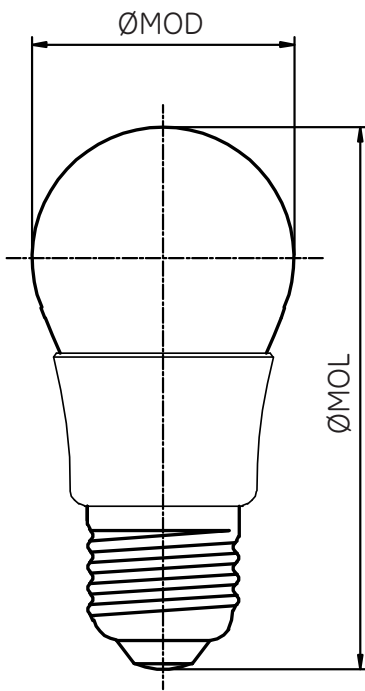

E27 cap		
	MOL [mm]	MOD [mm]
7W	93	45

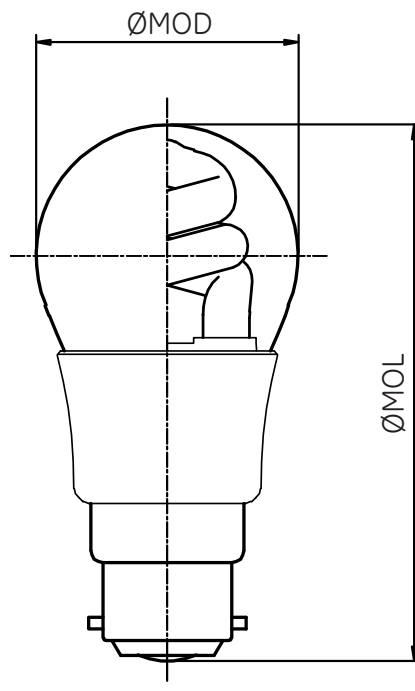

B22 cap		
	MOL [mm]	MOD [mm]
5W	92	45
7W	92	45

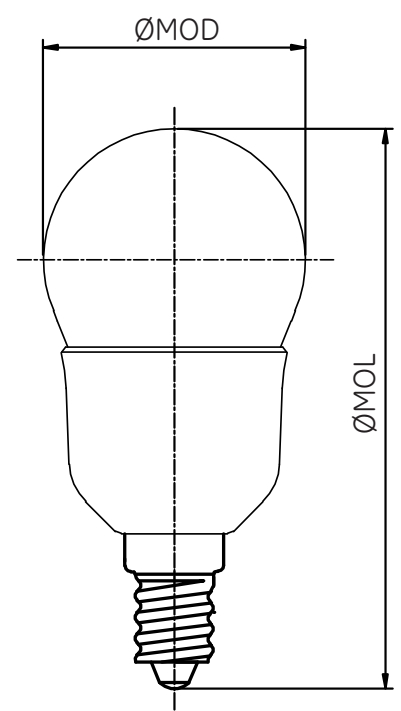

E14 cap		
	MOL [mm]	MOD [mm]
5W	96	45
7W	96	45

## Influence of ambient temperature on light output

Photometrical and light parameters of a fluorescent lamp depend on the mercury vapor pressure inside the lamp. Mercury vapor pressure in turn is controlled by temperature. When installed in a luminaire, the temperature of the air surrounding the lamp cap changes and this can affect the light output of the lamp. The effects of changes in ambient temperature for a typical lamp are shown on the graph.

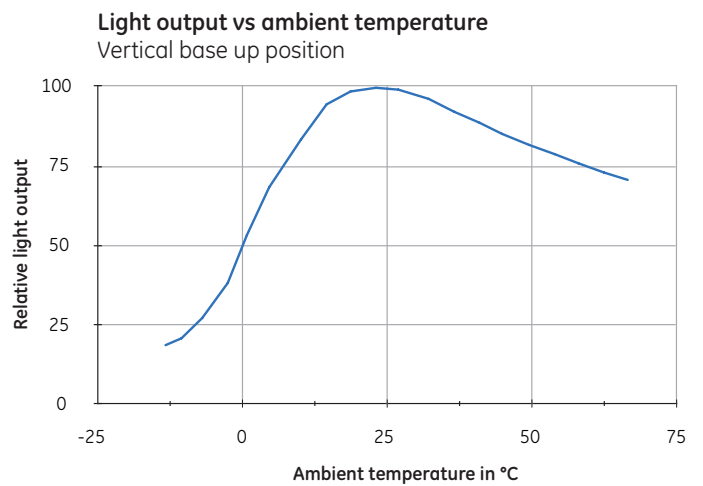

## Additional information – ErP Compliance

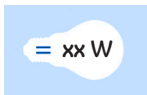

**Incandescent watt equivalence:** select the preferred wattage to enjoy the same light output as the original incandescent bulb while at the same time achieving significant energy savings. The Basic Data table and the updated EuP packaging include the CFL-Incandescent wattage equivalences according to the new EuP luminous flux standards.



**Switching cycle:** switching endurance is minimum the lamp lifetime expressed in hours if the starting time max. 0.3 sec. or minimum 30 000 if the starting time more than 0,3 sec. based on official EU standard – one minute on, three minutes off.



**Starting time:** the time needed for the lamp to start fully and remain alight. GE Lighting's CFL lamps are usually instant light on. Starting categories are: instant on (<0.3sec), quick (0.3-1sec), standard (1-1.5sec).  
**Spherical T2 8,000 hours starting time: standard**

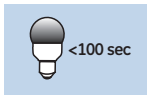

**Warm-up:** Lamp warm-up time to 60% lumens. Based on official EU standard the requirements are <40sec or <100sec for lamps containing mercury in amalgam form.



**Dimming:** not recommended to use with dimmers.

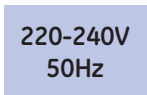

**220-240V 50Hz:** all lamps operate on 220-240 Volt (-10%; +6%), 50 Hertz

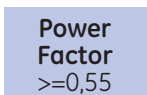

**Power Factor:** ratio of the measured active input power to the product of the supply voltage (r.m.s.) and the supply current (r.m.s.). measures how efficiently the current is being converted into real power. Lamps of power factor >0.9 are referred to as High Power Factor lamps, below that as Low Power Factor lamps. All CFL lamps above 25 watts sold in EU need to be High Power Factor lamp.

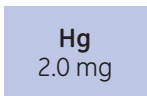

**Mercury content:** GE Lighting's CFL lamps contain a minimised level of mercury, some of our best-in class lamps as low as 0.9mg vs. the max. 2.5mg allowed by RoHS.



**Website:** instructions on how to dispose of lamps at end of life or in the case of accidental lamp breakage are available on the GE Lighting website.

## Application information

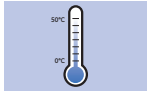

**Ambient temperature range:** temperature at which a lighting product can be safely used and can meet the claimed rated life. Outside of this temperature range, the product might still operate, although the life could be reduced. **Spherical T2 8,000 hours ambient operating temperature range: 0-50°C**

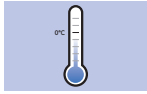

**Minimum starting temperature:** the lowest temperature condition at which the product can reliably start at within 3sec at 230V.  
**Spherical T2 8,000 hours minimum starting temperature: 0°C**

## Cautionary notices

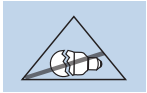

Lamp may shatter and cause injury if broken.



Usage in recessed fixtures could result in reduced life.



Do not use the lamp in enclosed fixtures.

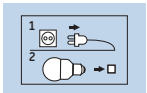

Switch off electricity before changing the bulb.



Do not grab the tubes when install/screw-in the lamp.