

FULFLO® “LT” SERIES

Fulflo® polymeric vessels for water filtration



Parker Fulflo® LT Series Polymeric Vessels are an ideal economical choice for low flow industrial and potable water applications. Standard and large diameter vessels accommodate 2-1/2 and 4-1/2 inch O.D. double-open-end Fulflo cartridges and meet FDA requirements for use with potable fluids. Both 10-in and 20-in vessels, with or without pressure relief vent, are available. Installation wrenches and brackets are optional.

BENEFITS

- Fulflo® polymeric vessels are available in two diameters and lengths, with or without relief vent
- The all polymeric, corrosion-resistant LT series vessels are economical alternatives to stainless steel vessels when high temperature and high pressure are not specified
- All models are made of materials that meet FDA requirements
- The LTG model vessels provide both 1 in and 1-1/2 in NPT connection in same head
- Positive head-to-shell "stop" prevents over tightening
- Unique O-ring design ensures effective sealing by positive tangential contact and eliminates accidental misplacement
- LT model vessels are ideal for Fulflo® bonded, pleated and wound cartridges, as well as activated carbon core models MMCT-10, MC10-2, MC20-2 and MC30-2
- LTG model vessels are ideal for Fulflo® TruBind® 400 series cartridges and 4-1/2 in O.D. wound cartridges in double-open-end style
- Optional installation wrenches accommodate faster cartridge Changeout
- Mounting brackets are available for pipe and wall installation
- LT series vessels are tested to industry standards of Water Quality Association for burst pressure, seal integrity, and fatigue resistance

APPLICATIONS

- Potable water
- Beverages
- Bottled water
- DI water
- Food products
- Process water
- Post oil/water separator polishing
- Leisure/commercial shipping bilge water
- Industrial discharge water
- Compressor condensate
- Alkaline parts washing

SPECIFICATIONS

Materials of Construction:

White talc-reinforced polypropylene head with clear styrene Acrylonitrile (SAN) shell.

Recommended Operating Conditions:

Maximum operating temperature: 125°F (52°C) @ 100 psi (6.9 bar)

Maximum operating pressure: LT:150 psi (10.3 bar) @ 75OF (22OC)

LTG: 125 psi. (8.6 bar) @75OF (22OC)

Maximum Recommended Flow Rate:

| | |
|-------|-----------------|
| LT10 | 6 gpm (23 lpm) |
| LT20 | 12 gpm (45 lpm) |
| LTG10 | 10 gpm (38 lpm) |
| LTG20 | 20 gpm (76 lpm) |

Connection Dimensions

| | |
|-----|---------------------------------------|
| LT | 3/4 in NPTF |
| LTG | 1 and 1 1/2 in NPTF (dual connection) |

Head-to-shell O-ring:

| | |
|-----------|--------------|
| LT model | 2-240 Buna N |
| LTG model | 2-358 Buna N |

Accepts Industry Standard Cartridge Sizes (Nominal):

| | |
|---------------------------|--|
| Lengths | |
| - 9 13/16 in (249 mm) | |
| - 20 in (508 mm) | |
| I.D. | |
| - 1 1/16 in (27 mm) | |
| O.D. | |
| - 2 1/2 in (64 mm) - LT | |
| - 4 1/2 in (114 mm) - LTG | |

FULFLO® “LT” SERIES

Fulflo® polymeric vessels for water filtration

PERFORMANCE ATTRIBUTES

Available Options for LT Model

| Option | Part Number |
|------------------------|-------------|
| Wrench for 10 in Shell | 6880-1-005 |
| Wrench for 20 in Shell | 6880-1-010 |
| L-Bracket - Wall Mount | 0820-6010 |
| U-Bracket - Pipe Mount | 0820-6015 |

Available Options for LTG Model

| Option | Part Number |
|------------------------|-------------|
| Wrench for 10 in Shell | 6880-6000 |
| Wrench for 20 in Shell | 6880-6001 |
| L-Bracket - Wall Mount | 0820-6001 |

Available Vessel Part Numbers

| LT Model | LTG Model |
|----------|-----------|
| LT10 | LTG10 |
| LT10V | LTG10V |
| LT20 | LTG20 |
| LT20V | LTG20V |

ORDERING INFORMATION

| Series | | Vessel Length | | Vent (in) | |
|--------|---|---------------|------|-----------|-------------|
| CODE | DESCRIPTION | CODE | INCH | CODE | DESCRIPTION |
| LT | Vessel for nominal 2 1/2 in O.D. cartridges | 10 | 10 | Blank | No Vent |
| | | 20 | 20 | V | Vent |
| LTG | Vessel for nominal 4 1/2 in O.D. cartridges | | | | |

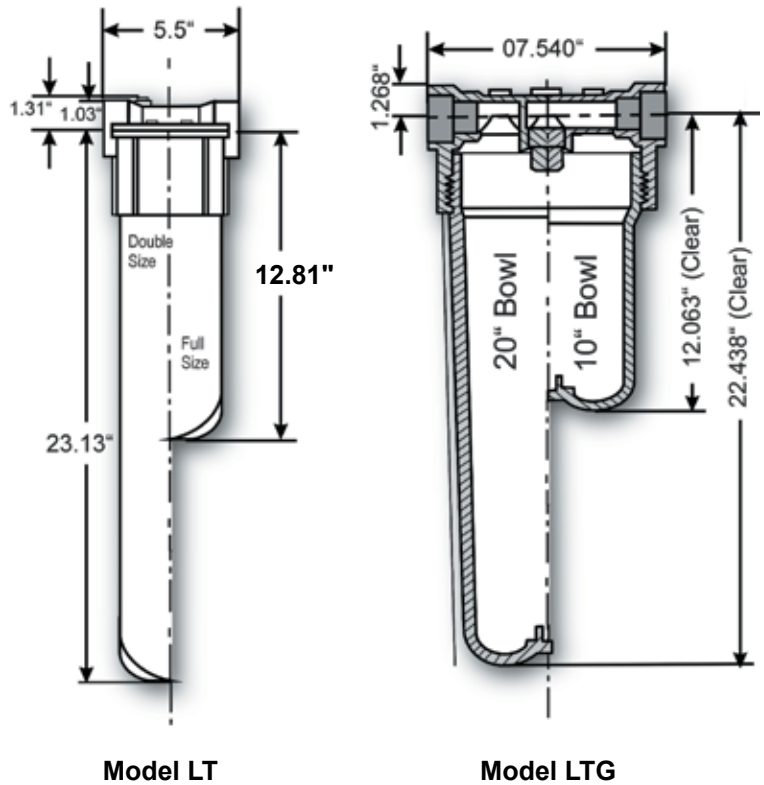

TECHNICAL SUPPORT AND PRODUCT INFORMATION

Parker provides our customers with unsurpassed product consistency and cost efficiency. Our experienced professionals can help you select the right solution for your application. Orders can be emailed directly to PAFsales@parker.com. For additional information contact your local distributor. Information on product specifications, applications and chemical compatibility can be found on our web site at www.parker.com or through the Oxnard office.

Parker designs and manufactures an extensive line of innovative solutions for specific applications in the Microelectronics, Biopharmaceutical, Food and Beverage, Coatings and Inks, Process and Chemical industries.

DISTRIBUTED BY:



Process Advanced Filtration Division
 2340 Eastman Avenue
 Oxnard, California, USA 93030
 Toll Free: +1 877 784 2234
 Phone: +1 805 604 3400
 Fax: +1 805 604 3401
PAFsales@parker.com
www.parker.com

Specifications are subject to change without notification.
 Fulflo® is a registered trademark of Parker Hannifin Corporation.
 Viton® is a registered trademark of E.I. DuPont de Nemours & Co., Inc.
 © 2007 Parker Hannifin Corporation.