

GT25 Series

0.64mm Contact Tab Size, 2.2mm Pitch, Wire-to-Board Connector



Space Saving



Wide Variation



Contact Reliability

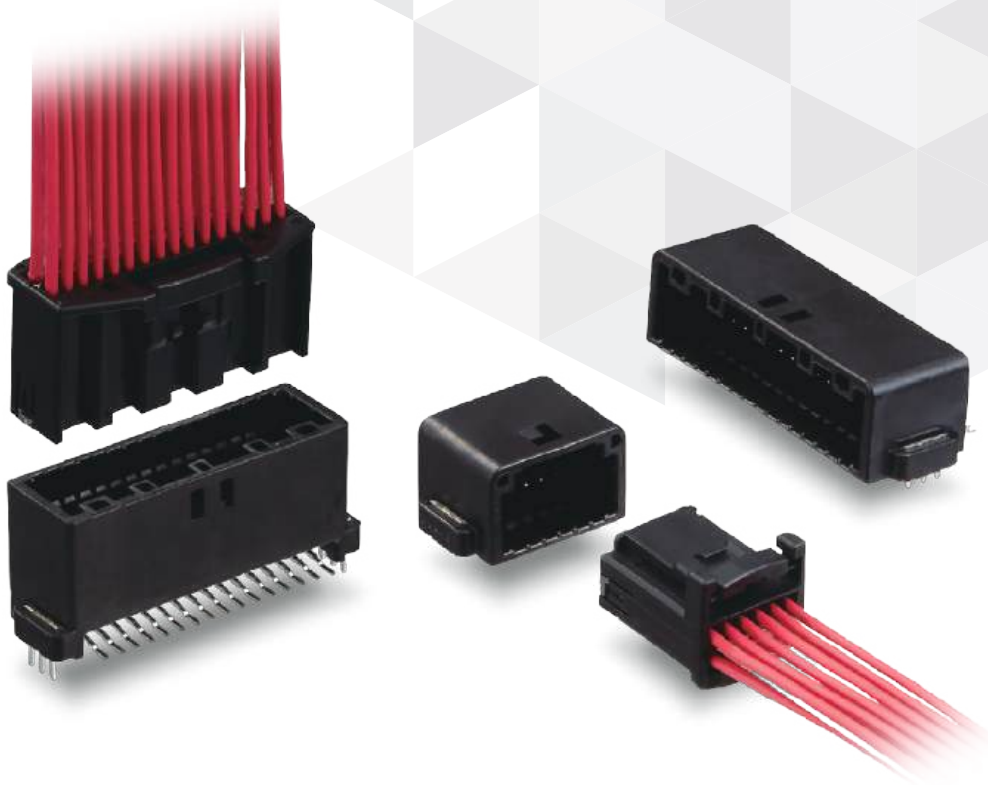

Features

1. Reduces PCB Mounting Space
(0.64mm Contact Tab Size / 2.2mm Pitch)
2. Wide Product Line-up
3. Prying Force: 98N Min.
4. Heat Resistant Up to 105°C
5. Clear Tactile Click
6. Can Be Mated with Other Manufacturers' Products

Application

Various ECU, ADAS and automated driving equipment, infotainment, etc.

Product Specifications

Rated Current	3A
Rated Voltage	250V AC
Operating Temperature (Note)	-40 to +105°C

Note: Includes temperature rise due to current flow.

Material / Finish

Component		Material	Color / Finish
Receptacle	Housing	Right Angle: PA	Black
		Straight: PPS	Black or Light Gray
	Contact	Brass	Tin Plating
	Retention Tab	Brass	Tin Plating
Plug	Housing	PPE	Black
	Crimp Contact	Copper Alloy	Tin Plating
	Retainer	PBT	Dark Gray

Product Number Structure

Refer to the chart below when determining the product specifications from the product number.
Please select from the product numbers listed in this catalog when placing orders.

■ Receptacle / Plug / Retainer

GT25 H2 - 24 D P - 2.2 H (##)

- ①
②
③
④
⑤
⑥
⑦

① Series Name	GT25	⑤ Contact Pitch	2.2mm
② No. of Pos.	8, 12, 16, 20, 24, 32, 40pos.	⑥ Component Type	V: Straight H: Right Angle HU: Housing R: Retainer
③ Columns	D: 2 Rows (Note)	⑦ Specifications	(10): Standard (31): Multiple Packaging Specifications for the Standard
④ Connector Type	P: Receptacle S: Plug		

Note: There is no single row variation.

■ Crimp Contact

GT25 H - 2024 SCF

- ①
②
③

① Series Name	GT25	③ Contact Gender	SCF: Female Contact
② Applicable Cable	2024: 20 to 22 AWG 2428: 24 to 26 AWG		

Receptacle

Right Angle THT Retention Tab

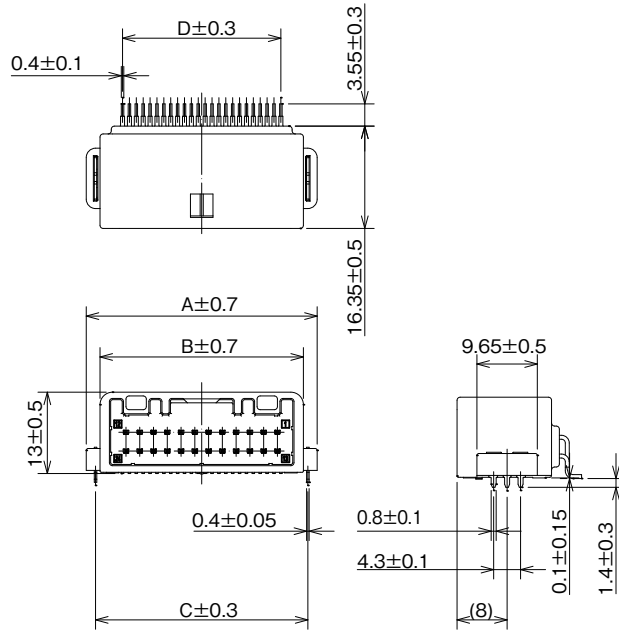

Unit : mm

Part No.	HRS No.	No. of Pos.	A	B	C	D	Purchase Unit (##):(10)	Purchase Unit (##):(31)
GT25H2-8DP-2.2H(##)	CL0775-0047-4-##	8	19.3	14.9	16.33	7.7	200pcs per reel 1 reel per box	200pcs per reel 8 reels per box
GT25H2-12DP-2.2H(##)	CL0775-0092-9-##	12	23.7	19.3	20.73	12.1		200pcs per reel 6 reels per box
GT25H2-16DP-2.2H(##)	CL0775-0089-4-##	16	28.1	23.7	25.13	16.5		200pcs per reel 5 reels per box
GT25H2-20DP-2.2H(##)	CL0775-0080-0-##	20	32.5	28.1	29.53	20.9		200pcs per reel 4 reels per box
GT25H2-24DP-2.2H(##)	CL0775-0081-2-##	24	36.9	32.5	33.93	25.3		
GT25H2-32DP-2.2H(##)	CL0775-0086-6-##	32	45.7	41.3	42.73	34.1		
GT25H2-40DP-2.2H(##)	CL0775-0090-3-##	40	54.5	50.1	51.53	42.9		

Right Angle THT Retention Tab, Reverse Lock Type

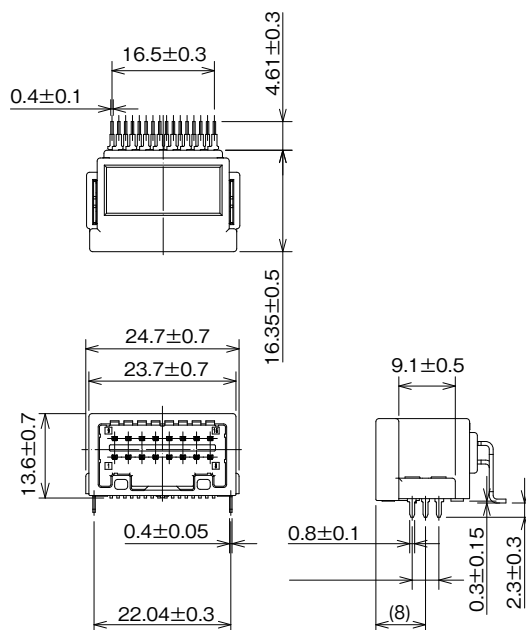

Part No.	HRS No.	No. of Pos.	Purchase Unit
GT25R-16DP-2.2H	CL0775-0130-0-00	16	180pcs per reel

Note: This receptacle is for reverse insertion of the plug.

Straight THT Retention Tab

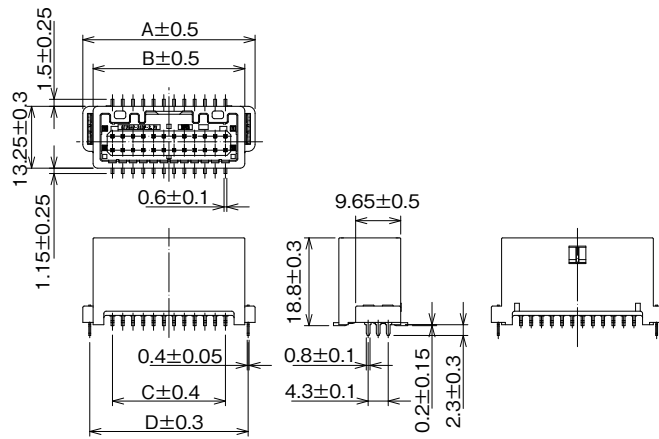
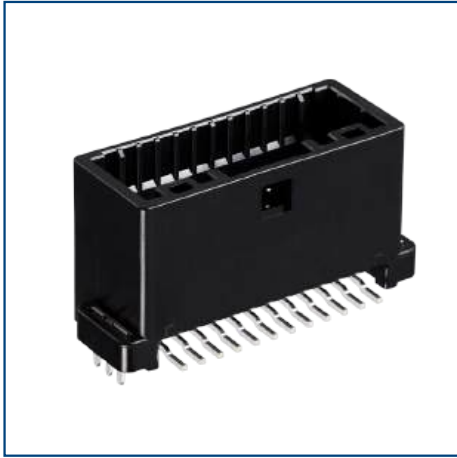

Unit : mm

Part No.	HRS No.	No. of Pos.	A	B	C	D	Purchase Unit
GT25-16DP-2.2V(56) (Note)	CL0775-0020-8-56	16	26.75	22.3	15.4	23.73	28pcs per tray

Note: The color is light gray for this connector only.

Unit : mm

Part No.	HRS No.	No. of Pos.	A	B	C	D	Purchase Unit
GT25H-12DP-2.2V(60)	CL0775-0050-9-60	12	23.7	19.3	11.0	20.73	32pcs per tray
GT25H-32DP-2.2V(60)	CL0775-0053-7-60	32	45.7	41.3	33.0	42.73	20pcs per tray

Unit : mm

Part No.	HRS No.	No. of Pos.	A	B	C	D	Purchase Unit
GT25H2-8DP-2.2V	CL0775-0094-0-00	8	19.3	14.9	6.6	16.33	56pcs per tray
GT25H2-24DP-2.2V	CL0775-0083-8-00	24	36.9	32.5	24.2	33.93	35pcs per tray
GT25H2-40DP-2.2V	CL0775-0085-3-00	40	54.5	50.1	41.8	51.53	28pcs per tray

Plug Housing

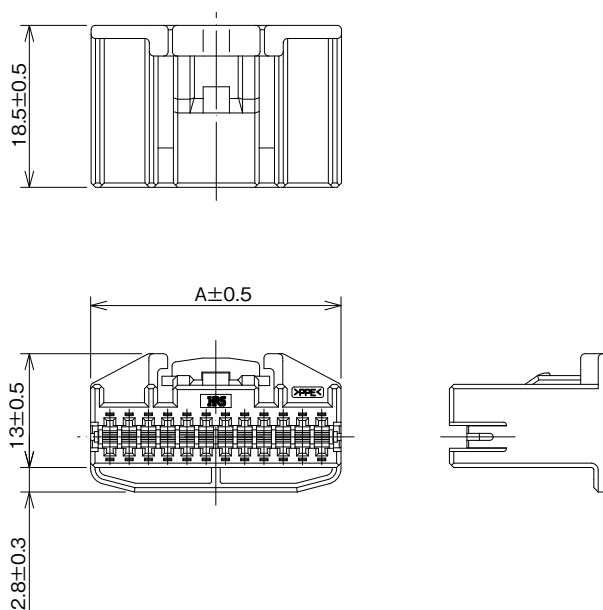

Unit : mm

Part No.	HRS No.	No. of Pos.	A	Purchase Unit
GT25-8DS-HU	CL0775-0064-3-00	8	11.0	100pcs per bag
GT25-12DS-HU(50)	CL0775-0037-0-50	12	15.4	
GT25-16DS-HU	CL0775-0066-9-00	16	19.8	
GT25-20DS-HU	CL0775-0075-0-00	20	24.2	
GT25-24DS-HU	CL0775-0068-4-00	24	28.6	
GT25-32DS-HU	CL0775-0042-0-00	32	37.4	
GT25-40DS-HU	CL0775-0023-0-00	40	46.2	

Note: Use with the retainer (GT25 -##DS-R), sold separately.

Retainer

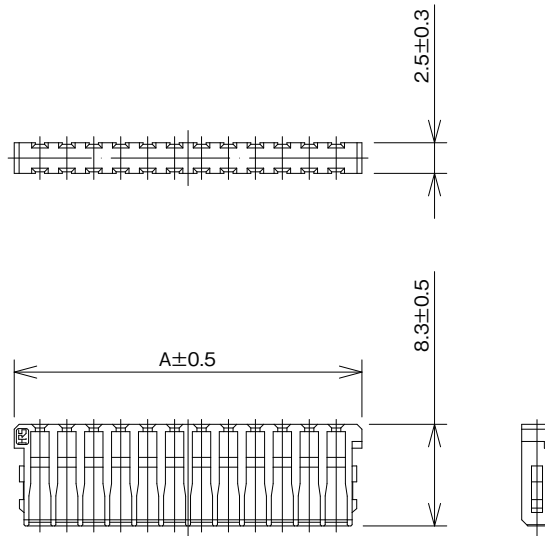

Unit : mm

Part No.	HRS No.	No. of Pos.	A	Purchase Unit
GT25-8DS-R	CL0775-0065-6-00	8	10.8	100pcs per bag
GT25-12DS-R	CL0775-0041-8-00	12	15.2	
GT25-16DS-R	CL0775-0067-1-00	16	19.6	
GT25-20DS-R	CL0775-0076-2-00	20	24.0	
GT25-24DS-R	CL0775-0069-7-00	24	28.4	
GT25-32DS-R	CL0775-0043-3-00	32	37.2	
GT25-40DS-R	CL0775-0028-0-00	40	46.0	

Note: Attach to the plug housing (GT25-##DS-HU) sold separately.

Plug Crimp Contact

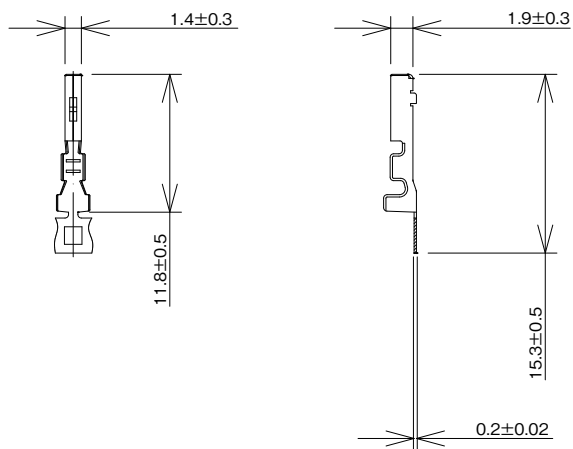

Part No.	HRS No.	Applicable Cable	Purchase Unit
GT25H-2024SCF	CL0775-0039-6-00	Wire Size: 20 to 22 AWG Cable Jacket Outer Diameter: ϕ 1.0 to 1.7	10,000pcs per reel
GT25HB-2428SCF	CL0775-0070-6-00	Wire Size: 24 to 26 AWG Cable Jacket Outer Diameter: ϕ 0.5 to 1.0	

Applicable Crimping Tool

Type	Part No.	HRS No.	Applicable Contact
Crimping Machine	CM-105C	CL0901-0001-0-00	-
Applicator	AP105-GT25H-2024S	CL0901-5206-3-00	GT25H-2024SCF
	AP105-GT25HB-2428S	CL0901-5230-8-00	GT25HB-2428SCF

Note 1: Conduct crimping based on the "Crimp Quality Standard" and "Crimp Condition Table".

Note 2: Problems with tools not specified by Hirose are outside the scope of warranty.

Usage Precautions

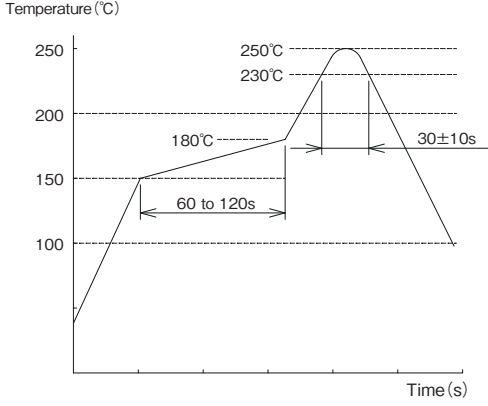
Recommended Temperature Profile	 <p>Temperature (°C)</p> <p>250 230 200 180 150 100</p> <p>Time (s)</p> <p>60 to 120s 30±10s</p> <p>250°C 230°C 180°C</p>	<p>【Conditions】</p> <ol style="list-style-type: none"> 1. Reflow Heating Method Used : Far infrared, air atmosphere or nitrogen 2. Peak Temperature : 250°C Peak 3. Heated part : 230°C Min. 20-40 sec. 4. Preheat Temperature : 150 to 180°C 90±30 sec. 5. Cycles : 2 times Max. 6. Recommended Solder Thickness : 0.15mm
Recommended Manual Soldering Conditions	Soldering iron temperature: 280 to 300°C , Soldering time: within 2 seconds	
Precautions	<ol style="list-style-type: none"> 1. Excessive pull force during unmating may damage the connector. If it is difficult to remove, push in lightly once and then release the lock. 2. Always make sure to turn off the power before reinserting the connector. 3. Do not directly touch the contact when electricity is flowing since it is extremely dangerous. 4. Contact a Hirose representative for harness procedures or handling manuals. 	

While Taking into Consideration

Specifications mentioned in this catalog are reference values.

When considering to order or use this product, please review the Drawing and Product Specifications sheets.

Use an appropriate cable when using the connector in combination with cables.

If considering usage of a non-specified cable, please contact your sales representative.

If assembly process is done by jigs & tools which are not identified by Hirose, the warranty of the product may be affected.

If considering usage for below mentioned applications, please contact your sales representative.

In cases where the application will demand a high level of reliability, such as automotive, medical instruments, public infrastructure, aerospace/ defense etc. Hirose must review before assurance of reliability can be given.