

# Keysight Technologies

## 8761A/B Microwave Switches

### Technical Overview

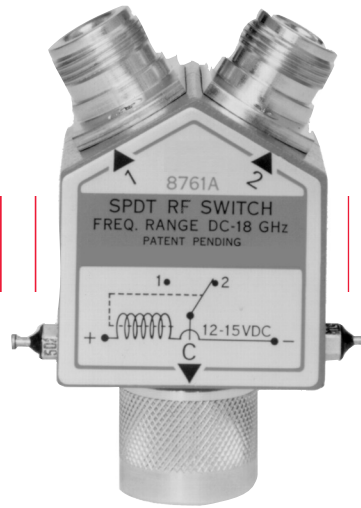

- Broadband (dc to 18 GHz)
- User specified connectors (over 250 possible combinations)
- Excellent repeatability (typically 0.03 dB after 1,000,000 cycles)
- Environmentally rugged

## Product Description

The Keysight Technologies, Inc. 8761A and 8761B are single-pole, double-throw coaxial switches with excellent electrical and mechanical characteristics for 50-ohm transmission systems operating from dc to 18 GHz. Both switches feature broadband operation, long life, low SWR, excellent repeatability, and magnetic latching solenoids. The 8761A and 8761B switches are small and lightweight, making them ideal for applications where space is limited. Because of their versatility and excellent electrical performance, they are well suited for automated testing and systems applications. The A version is for 12 to 15 VDC operation, and the B version uses 24 to 30 VDC solenoid drive voltage.

The Keysight 8761A/B Series can be custom configured with any combination of Type-N, SMA, and precision 7-mm connectors, thus enabling the user to “custom design” a connector arrangement and eliminate the need for connector adapters.

## Electrical Performance

These switches have proven reliable in Keysight microwave instrumentation, special purpose test equipment, and many other applications. They have been optimized for broadband operation, high isolation, minimal insertion loss, low SWR, and high repeatability.

### High Isolation

High port-to-port isolation is important in applications requiring wide dynamic range such as receiver sensitivity testing. The RF structure designs used for these switches yield the high isolation shown in Figure 1.

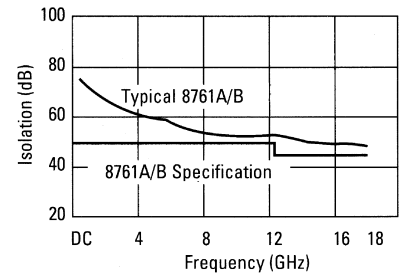

Figure 1. Typical port-to-port isolation

### Low Insertion Loss

Low insertion loss is very desirable in many applications where the user needs to minimize the loss of signal power. Using miniature gold-plated contacts, these switches offer the low insertion loss shown in Figure 2.

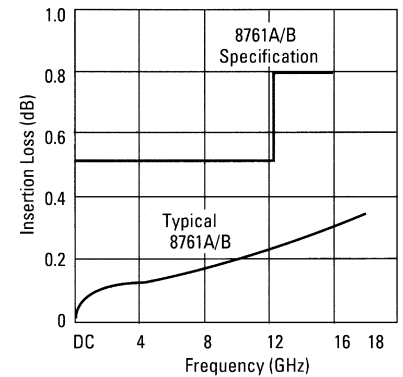

Figure 2. Typical insertion loss

### Low SWR

Low SWR is an important characteristic for switches because transmission line mismatches degrade the measurement system accuracy. Through the use of “edge line” design and precision machining, these switches offer the excellent SWR shown in Figure 3.

### High Repeatability

For measurement system applications, repeatability of the switched connection is a key factor in minimizing measurement error. The excellent repeatability of these switches (typically 0.03 dB after one million switching operations) has been achieved by employing gold-plated contacts and edge line design for the transmission line. This unique design feature of switching only the center conductor eliminates high friction sliding contacts, and results in long life and highly repeatable measurements.

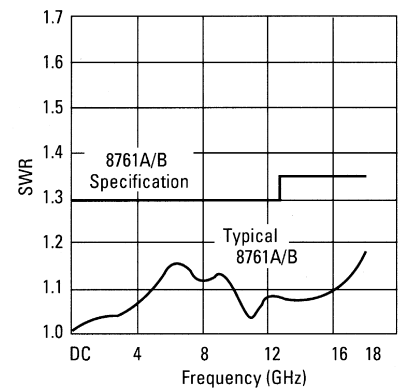

Figure 3. Typical SWR for SMA connection

The 8761 is a “break before make” switch controlled by a magnetic latching solenoid. Solenoid voltages of 12 and 24 volts are available. To change the state of the switch requires a reversal of the voltage polarity for at least 20 milliseconds (see Figure 4). Once switched, the solenoid is latched by strong permanent magnets.

### Typical Keysight 8761A Driver Circuit<sup>1</sup>

Figure 5 shows a typical driver circuit which uses a clock driver to control the 8761A switch. A TTL “HI” input to the circuit results in +V at point Q and -V (ground) at point R. Conversely, a TTL “LO” input results in -V (ground) at point Q and +V at point R. Internal diodes in the DS0026 suppress inductive voltage spikes.

### Connector Information

The Keysight 8761A/B switches are available with any combination of SMA, Type-N, precision 7-mm (mates with APC-7), and 50-ohm termination. This feature enables the user to custom design a single switch or multiple switch configuration for a specific application. By properly specifying connector options, switch trees can be configured to provide single-pole multi-throw as well as multi-pole multi-throw functions, all without the need for interconnecting cables. To specify connector options, refer to the ordering example.

### Mechanical Information

Three versions of the precision 7-mm connector are available on the 8761A/B which mate with the APC-7 connector, but differ slightly from the standard APC-7 to conserve space. One of these versions (option 102, 202, or 302) has a fixed threaded sleeve and the other (option 103, 203, or 303) has a coupling nut. The third precision 7-mm connector (option 104, 204, or 304) is designed to be used with a 0.250-in. outer diameter, semirigid coaxial cable. This connector is the same as the 7-mm option 102, 202, or 302 connector described above, with the exception of the center conductor which is female and accepts the center conductor of the semi-rigid coax. The fittings for a compatible connector on the semi-rigid coax are shown in Figure 6.

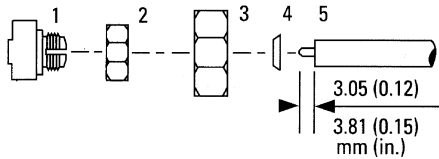

	Part Number
1. Cable Terminator	08742-2028
2. .375-32 Clamp Nut	0590-0035
3. Cable Coupling Nut	08740-2081
4. Cable Washer	5000-8676
5. Semi-rigid Coax Cable, UT-250*	

\* Uniform Tubes Inc., Collegeville, PA. Dimensional drawings for items 1 through 4 above are available upon request.

Figure 6. Cable assembly to mate with the 7-mm connector for UT-250 cable (option code 4)

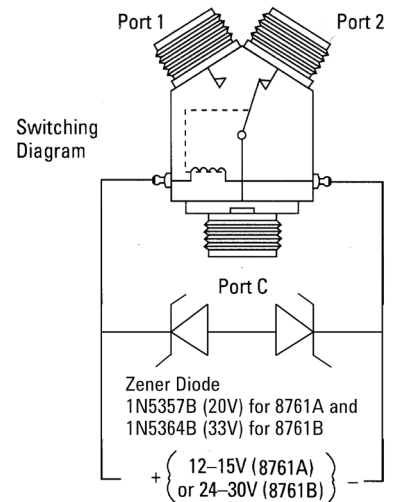
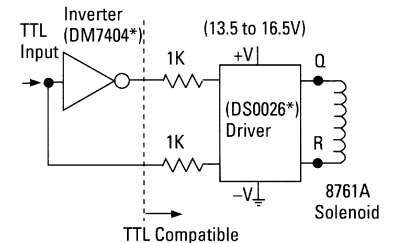

Figure 4. To connect ports 2 and C (as shown) requires the indicated solenoid voltage for at least 20 milliseconds. Reversing the polarity of the solenoid voltage connects ports 1 and C.



\*National Semiconductor part numbers, also supplied by other vendors.

Figure 5. Typical 8761A driver circuit

1. The switch solenoids are not designed to withstand continuous drive current due to excessive coil heating. To maximize switch life, Keysight recommends actuation using only pulsed drive. In this case, the pulse duration must be at least 20 milliseconds long, in order to ensure that the switch will fully latch. Also, Keysight recommends using back-to-back zener diodes connected in parallel with the switch solenoid, in order to minimize excessive fly-back currents through the solenoid. Refer to Figures 4 and 5 to see recommended connection configurations.

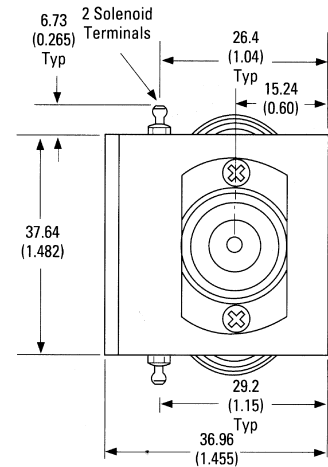
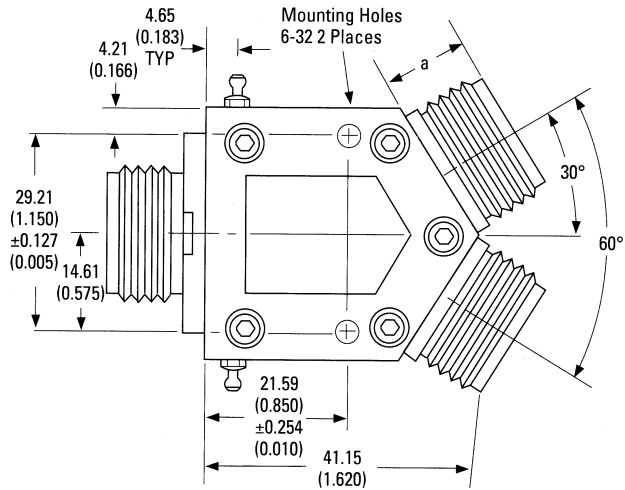

## Connector Options

Keysight 8761A/B		
Connector Options	Connector Type	Dimension "a" mm (in.)
100, 200, 300	Type-N Female	13.72 (0.540)
101, 201, 301	Type-N Male	19.79 (0.775)
102, 202, 302	7-mm Threaded Sleeve (APC-7)	9.27 (0.365)
103, 203, 303	7-mm Coupling Nut (APC-7)	11.94 (0.470)
104, 204, 304	7-mm for UT-250 Coax	9.27 (0.365)
105, 205, 305	SMA Female	16.13 (0 @ 635)
106, 206, 306	SMA Male	17.15 (0.675)
107, 207	50-ohm Termination <sup>2</sup>	30.5 (1.20)

Replaceable Parts: Refer to the Keysight 8761A/B Operating Note.

2. Option 107, 207 available on port 1 or port 2 only.

## Specifications

Keysight 8761A/B	
Switch Type	Single-pole double-throw, break before make, latching solenoid
Frequency Range	DC to 18 GHz
Insertion Loss	DC to 12.4 GHz: <0.5 dB DC to 18.0 GHz: <0.8 dB
Isolation	DC to 12.4 GHz: >50 dB DC to 18.0 GHz: >45 dB
Characteristic Impedance	50 $\Omega$
<b>SWR<sup>1</sup></b>	
<b>Connector Type</b>	
Type N	DC to 12.4 GHz: 1.20 DC to 18.0 GHz: 1.25
7-mm (APC-7) <sup>1</sup>	DC to 12.4 GHz: 1.15 DC to 18.0 GHz: 1.20
3-mm (SMA)	DC to 12.4 GHz: 1.30 DC to 18.0 GHz: 1.35
50 $\frac{1}{2}$ Load	SWR degraded by 0.05 when used with above connector types.
Input Power Rating	10 watts average, 5 k watts peak (2 watts average, 100 watts peak with option 7, 50-ohm termination)
Life	>1,000,000 switchings
Repeatability	0.03 dB after 1,000,000 switchings (Typical)
Switching Speed	Maximum: 50 milliseconds
Coil Voltage	8761A: 12 V (12 to 15 V) 8761B: 26 V (24 to 30 V)
Switching Current	8761A: 80 mA @ 12 V 8761B: 65 mA @ 26 V
Coil Impedance	8761A: 150 $\Omega$ , 90 mH 8761B: 400 $\Omega$ , 300 mH
<b>Environmental Qualifications</b>	
Operating Temp.	-25°C to +70°C
Humidity	95% RH, +40°C, 5 days
Vibration	0.03", 10 to 55 Hz
Shock	30 G's, 11 ms
Weight	Net: 140 to 220 gm (5 to 8 oz) Shipping: 220 to 300 gm (8 to 11 oz)

1. 8761A/B SWR specifications apply when all ports are of the same connector type. For mixed connector types, the larger of the two SWR's applies. Type-N connector SWR specifications apply to 7-mm for UT-250 Coax connectors (option 104, 204, or 304).

2. Either option will connect to a standard, sexless, 7-mm connector. To daisy-chain two 8761A's you must use one option 102, 202, or 302 and one option 103, 203, or 303 on the two mating connectors. If you have two of the same options, you will need to use a cable with two standard 7-mm connectors.

## Ordering Information

To order the Keysight 8761A/B switch, connector configuration and solenoid voltage must be specified as shown in the ordering example below.

### Connector

Options	Connector Type
100, 200, 300	Type-N Female
101, 201, 301	Type-N Male
102, 202, 302	7-mm Threaded Sleeve (APC-7) <sup>2</sup>
103, 203, 303	7-mm Coupling Nut (APC-7) <sup>3</sup>
104, 204, 304	7-mm for UT-250 Coax
105, 205, 305	SMA Female
106, 206, 306	SMA Male
107, 207	50-ohm Termination

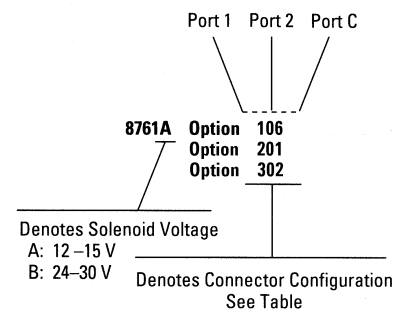
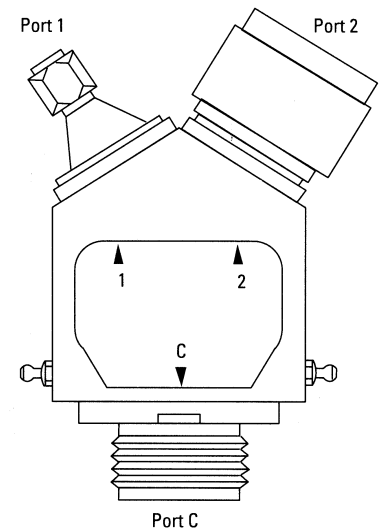

myKeysight

myKeysight

[www.keysight.com/find/mykeysight](http://www.keysight.com/find/mykeysight)

A personalized view into the information most relevant to you.



[www.lxistandard.org](http://www.lxistandard.org)

LAN eXtensions for Instruments puts the power of Ethernet and the Web inside your test systems. Keysight is a founding member of the LXI consortium.

Keysight Channel Partners

[www.keysight.com/find/channelpartners](http://www.keysight.com/find/channelpartners)

Get the best of both worlds: Keysight's measurement expertise and product breadth, combined with channel partner convenience.

[www.keysight.com/find/mta](http://www.keysight.com/find/mta)

For more information on Keysight Technologies' products, applications or services, please contact your local Keysight office. The complete list is available at: [www.keysight.com/find/contactus](http://www.keysight.com/find/contactus)

#### Americas

Canada	(877) 894 4414
Brazil	55 11 3351 7010
Mexico	001 800 254 2440
United States	(800) 829 4444

#### Asia Pacific

Australia	1 800 629 485
China	800 810 0189
Hong Kong	800 938 693
India	1 800 112 929
Japan	0120 (421) 345
Korea	080 769 0800
Malaysia	1 800 888 848
Singapore	1 800 375 8100
Taiwan	0800 047 866
Other AP Countries	(65) 6375 8100

#### Europe & Middle East

Austria	0800 001122
Belgium	0800 58580
Finland	0800 523252
France	0805 980333
Germany	0800 6270999
Ireland	1800 832700
Israel	1 809 343051
Italy	800 599100
Luxembourg	+32 800 58580
Netherlands	0800 0233200
Russia	8800 5009286
Spain	0800 000154
Sweden	0200 882255
Switzerland	0800 805353
	Opt. 1 (DE)
	Opt. 2 (FR)
	Opt. 3 (IT)
United Kingdom	0800 0260637

For other unlisted countries:  
[www.keysight.com/find/contactus](http://www.keysight.com/find/contactus)  
(BP-06-09-14)