

These dimensions will be especially checked at delivery
Only inspection dimensions
With /± marked dimensions are only valid for internal use

Diese Maße werden bei Abnahme besonders geprüft
Ausschließlich Prüfmaße
Mit /± gekennzeichnete Maße sind nur für interne Zwecke gültig

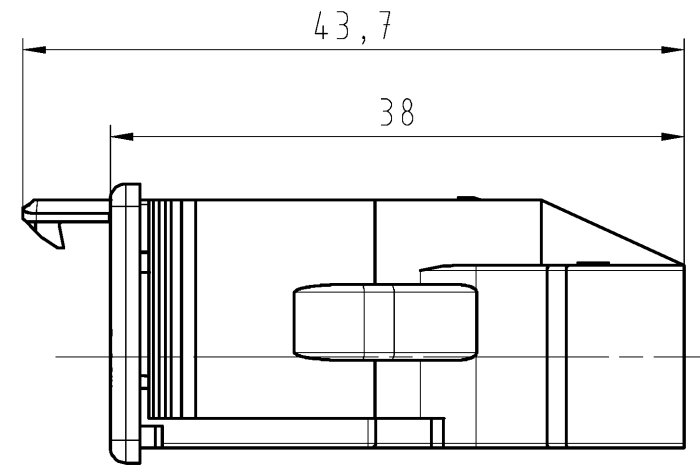
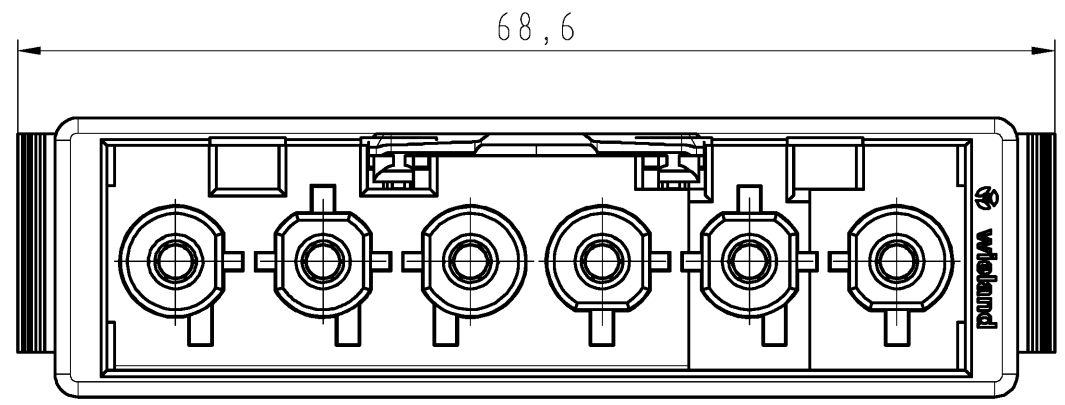

**Blechausschnitt
sheet cutout**

Blechdicke/
sheet thickness:
0,5 - 2,5mm

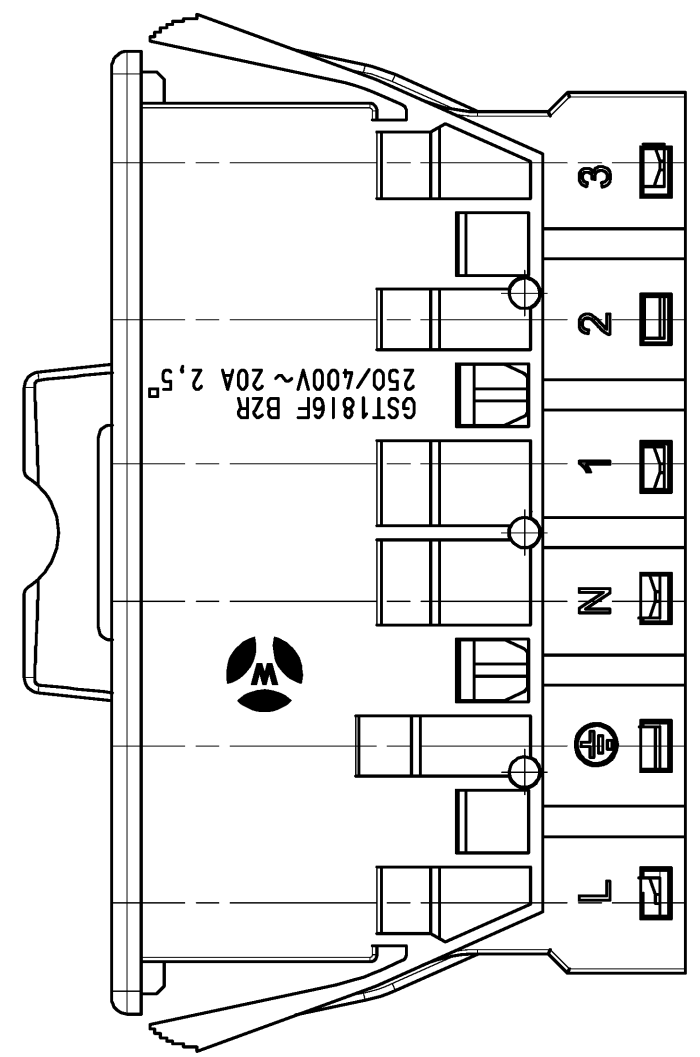
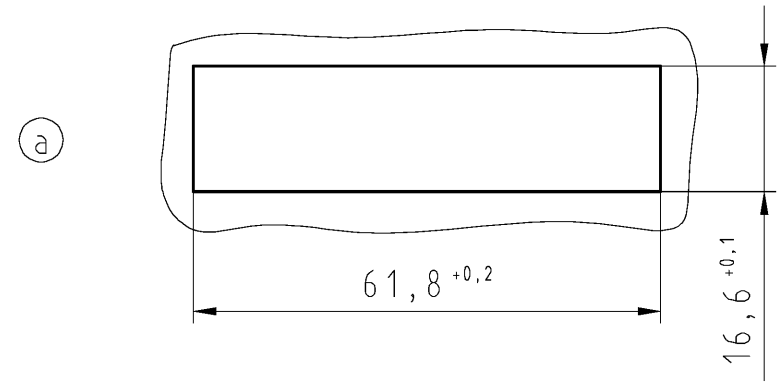

M/scale 1:1

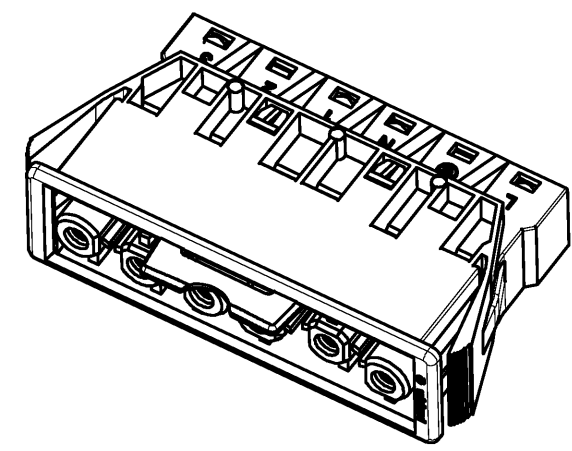

Tolerierung Size ISO 14405 (E)/Tolerance system Size ISO 14405 (E). (This ISO-standard describes the envelope principle. According to the envelope principle the deviations of form and parallelism are limited by the size tolerances).				ja/yes <input checked="" type="checkbox"/> Stoffverbots- und Deklarationsliste nach WN 5020.010 ist einzuhalten. Conformity with Wieland document WN 5020.010 e (list of prohibited / deklarable hazardous substances) to be declared!			
Freitoleranz nach General tolerance		CAD - Zeichnung, keine manuellen Änderungen CAD - drawing, no manual modifications allowed		1. Verwendung: - First Use:		Blatt: 1 von 1 Sheet: of	
/		Werkstoff/Material Farbe/colour: schwarz/black türkisblau/ turquoise blue		2014 Tag/Date Name		Zeichnung Nr./Drawing No.	
/		Maßstab/Scale 2:1		gezeichnet drawn 07.11. Ritter		92.061.8658.1 01K a	
/		Vol. mm ³ Ofl./Surf. mm ²		geprüft checked Normgepr. Stand. check		Maße in mm/Dimensions are in mm	
/		Ersatz für/Replacement for: -		Type		Benennung/Title	
a 29.04.2015/ Index Datum / Blatt Date / Sheet		wieland www.wieland-electric.com		GERAETEANSCHLUSS_BU		device connection female 250/400V AC 20A 2,5qmm	
Änderung/Revision							

Type: GST1816F B2 R V SWPB