

MINISTART Softstarter And Softstop Device GF 9016

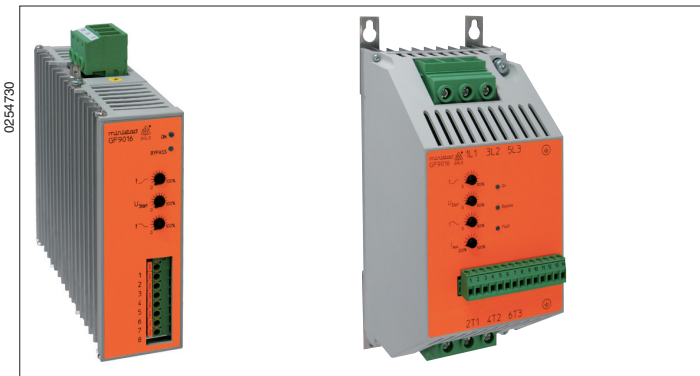

- For soft and shockfree start of your asynchronous motors
- Less wearing and longer life for your motors and components
- Space saving and easy fitting
- Reduce load from supply mains by reducing of starting current
- According to IEC/EN 60 947-4-2
- Softstart with softstop
- For motors up to 37 kW
- 2-phase control
- Adjustable start up and deceleration time als well as starting voltage, optionally with kickstart
- Without auxiliary voltage
- W3 connection is possible
- As option current control on softstart
- Up to 15 kW: width 45 mm
Up to 22 kW: width 52.5 mm

Function Diagram

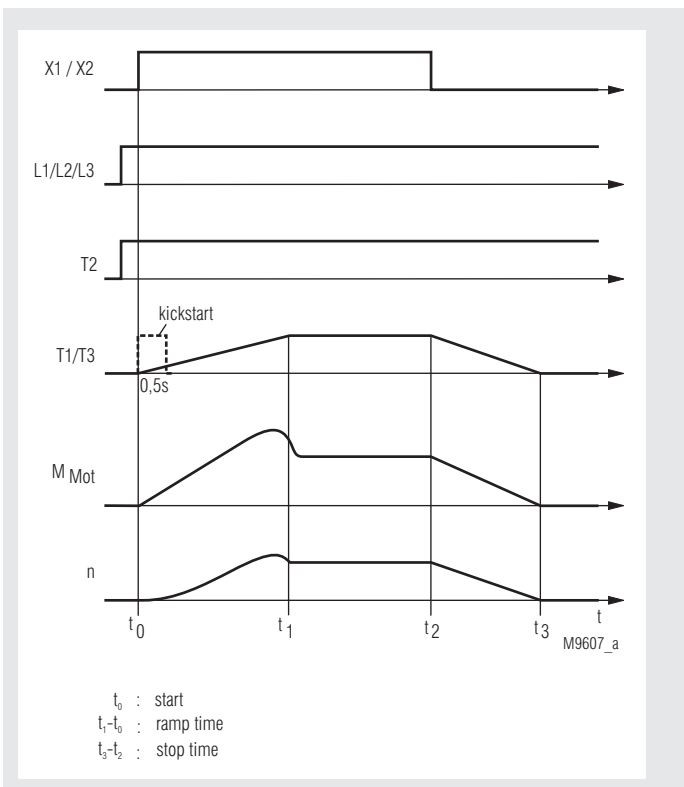

Approvals and Marking



Applications

- Motors with gear, belt or chain drive
- Fans, pumps, conveyor systems, compressors
- Packaging machines, door drives
- Start current limiting on 3 phase motors

Function

Softstarters are electronic devices designed to enable 1-phase or 3-phase induction motors to start smoothly. The GF 9016 slowly ramps up the current on two phases, therefore allowing the motor torque to build up slowly. This reduces the mechanical stress on the machine and prevents damage to conveyed material.

When the motor is up to full speed the power semiconductors in GF 9016 are bridged to prevent internal power losses and heat build up. In addition GF 9016 allows a softstop function prolonging the stop time of the motor, preventing high counter torques from abruptly stopping the motor.

Block Diagram

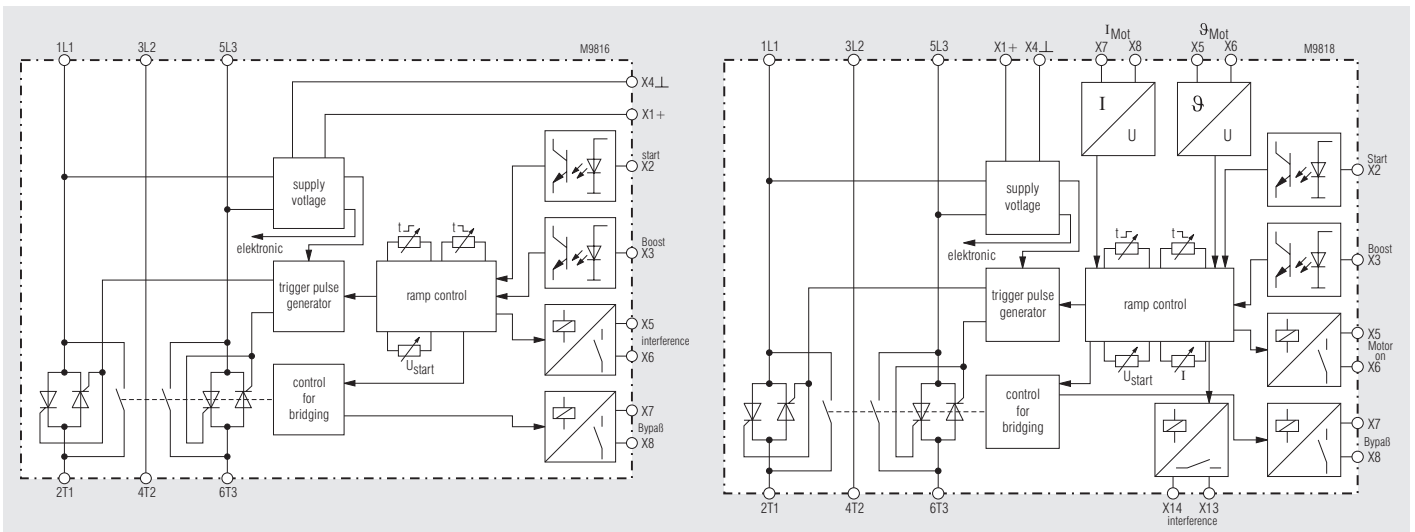

up to 22 kW

up to 37 kW

Indication			
LED green	ON	=	power connected
LED yellow	ON	=	power semiconductors bridged flashes with rising or falling speed at softstart - soft-stop flashes with same frequency at error (see table)
LED red: On, when failure detected (only on devices ≥ 25 kW)			

Failure codes up to 22 kW-devices

Fault	LED yellow	Operating state
1	yellow LED flashes 2 x times with short space	device overloaded / heat sink temperature too high
2	yellow LED flashes 3 x times with short space	failure in electronics
3	yellow LED flashes 4 x times with short space	firing error in phase 1
4	yellow LED flashes 5 x times with short space	firing error in phase 3
5	yellow LED flashes 6 x times with short space	error in motor phase/ power semicond. defective in phase 1
6	yellow LED flashes 7 x times with short space	error in motor phase/ power semicond. defective in phase 3
7	yellow LED flashes 8 x times with short space	general synchronising error

Failure codes from 25 kW-devices

Fault	LED yellow	Operating state
0	yellow LED flashes 1 x times with short space	low supply voltage
1	yellow LED flashes 2 x times with short space	device overloaded / heat sink temp. too high; motor overtemp.
2	yellow LED flashes 3 x times with short space	current control time out
3	yellow LED flashes 4 x times with short space	phase failure 1
4	yellow LED flashes 5 x times with short space	phase failure 2
5	yellow LED flashes 6 x times with short space	phase failure 3
6	yellow LED flashes 7 x times with short space	frequency failure
7	yellow LED flashes 8 x times with short space	firing error in phase 1
8	yellow LED flashes 9 x times with short space	firing error in phase 3
9	yellow LED flashes 10 x times with short space	mains failure

Motor load must always be connected as continuous operation of the softstart with no load may cause overheating of the motor and softstart. It is recommended that the softstart is protected by superfast semiconductor fuses rated as per the current rating of the softstart or motor. However, standard line and motor protection is acceptable, but for high starting frequencies motor winding temperature monitoring is recommended.

Technical Data	
Nominal voltage:	3 AC 400 V \pm 15 % (others on request)
Nominal frequency:	50/60 Hz
Rated current:	16 25 32 45 50 65 75 A
Nominal motor power at P_N at 400 V:	7.5 11 15 22 25 30 37 kW
Min. motor power:	approx. 0.2 P _N
Start torque:	20 ... 70 %
Ramp time:	0.5 ... 10 s
Deceleration time:	0.5 ... 10 s
Recovery time:	200 ms
Switching frequency:	60 45 35 10 35 25 30 1/h
I²-Power semiconductor fuse	4900 4900 6050 6600 6600 11200 25300 A ² s

General Data

Temperature range:	0 ... + 45°C
Storage temperature:	- 25 ... + 70°C
Overvoltage category / pollution degree:	III / 2
Insulation class:	3
Peak voltage resistance:	4 kV
Degree of protection:	IP 20 IEC/EN 60 529
Wire connection	
Load terminals up to 22 kW:	plug in screw terminal
Stranded wire:	6 6 16 16 25 25 25 mm ²
Control terminals:	
up to 22 kW:	1.5 mm ² cage clamp terminals
to 25 kW:	2.5 mm ² screw terminal
Mounting:	DIN-rail mounting IEC/EN 60 715
Weight:	1.0 1.0 1.0 1.0 1.5 1.5 2.2 kg

Dimensions

Width x height x depth (incl. terminals)

7,5 / 11 kW:	45 x 173 x 158 mm
22 kW:	52.5 x 178 x 158 mm
25 / 30 kW:	103 x 230 x 125 mm
37 kW:	103 x 230 x 140 mm

Standard Type

GF 9016	3 AC 400 V	50/60 Hz	7.5 kW
• Nominal voltage:	3 AC 400 V		
• Nominal motor power:	7.5 kW		
• Width:	45 mm		

Ordering Example

GF 9016 3 AC 400 V 50/60 Hz 7.5 kW AC 230 V

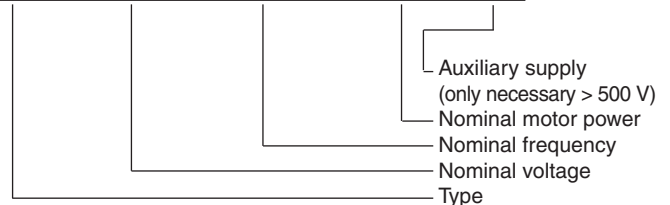

Accessories

Current transformer for current control on softstart on request

Control Input

Up to 22 kW

Connect contact to X1, X2 and select softstart (close contact) or softstop (open contact). As option the unit can also be started by an external control voltage of DC 10-24 V. This has to be connected to terminals X2, X3, X4 connecting means starting up, disconnection stopping. On terminal X3 a kickstart function can be activated. This is useful on motors that have a high starting load as e.g. mills, breakers, conveyors. Kickstart takes 0.5 sec at fully switched thyristors.

From 25 kW

X5, X6: Connection for notor thermistor, must be linked, when not used

X7, X8: Connection for current transformer with current control Input is only active, if a current transformer is connected

Indicator Outputs

Up to 22kW

X5, X6: error at phase failure, frequency variation, thyristor failure, overtemperature of the unit, disconnected motor. Reset by switching the unit off and on.

X7, X8: softstart finished, semiconductor bridged.

≥ 25 kW

X9, X10: motor runs, device on operation

X11, X12: end of softstart, semiconductor bridged

X13, X14: interference (common alarm)

Adjustment Facilities

Potentiometer	Description	Initial setting
U_{start}	Starting voltage	fully anti-clockwise
t_r	Ramp-up time	fully clockwise
t_d	Deceleration time	fully clockwise
I (only for 25 kW)	current controlled start	fully anti-clockwise

Set-up Procedure

Set potentiometer " U_{start} " to minimum (fully anti-clockwise).

Set potentiometer " t_r " to maximum (fully clockwise).

Set potentiometer " t_d " to mid position.

Start the motor and turn potentiometer " U_{start} " up until the motor starts to turn without excessive humming.

Stop the motor and restart.

Adjust potentiometer " t_r " to give the desired ramp time.

Stop and restart the motor.

Adjust potentiometer " t_d " to give the desired deceleration time.

Stop and restart the motor, readjusting the potentiometers until the desired starting/stopping characteristics are achieved.

- **Attention:** If the ramp-up time is adjusted to short, the internal bridging contact closes before the motor is on full speed. This may damage the bridging contactor or bridging relay.



Safety Instructions

- Never clear a fault when the device is switched on
- **Attention:** This device can be started by potential-free contact, while connected directly to the mains without contactor (see application example). Please note, that even if the motor is at rest, it is not physically separated from the mains. Because of this the motor **must** be disconnected from the mains via the corresponding manual motor starter.
- The user must ensure that the device and the necessary components are mounted and connected according to the locally applicable regulations and technical standards.
- Adjustments may only be carried out by qualified specialist staff and the applicable safety rules must be observed.



Application Examples

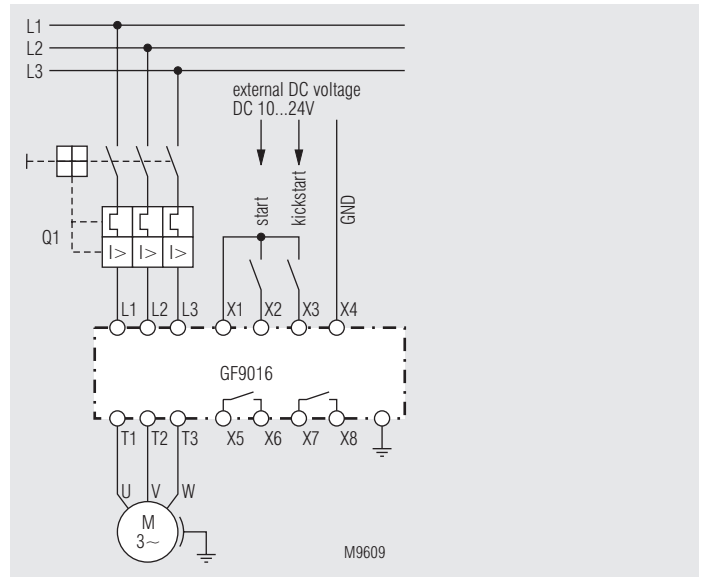

Softstart with softstop

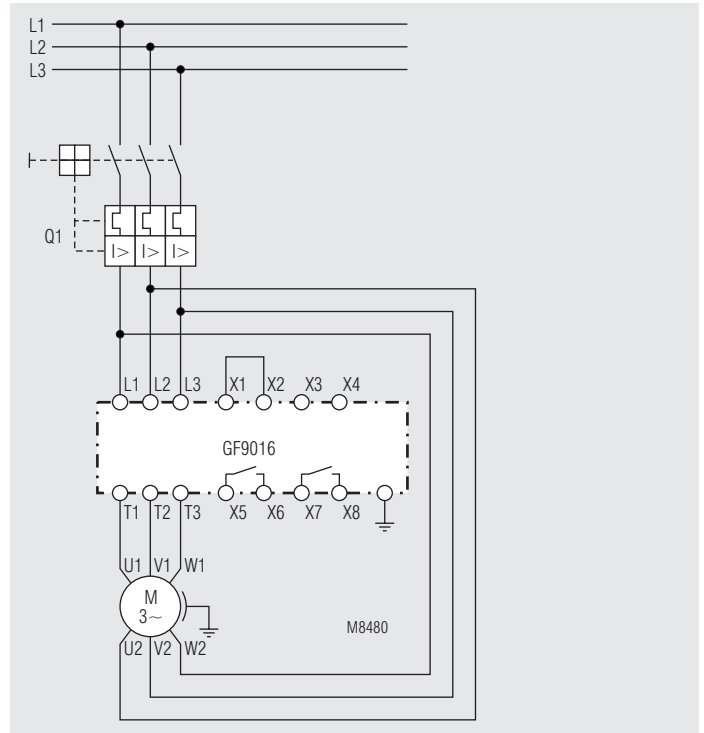

Softstart in a $\sqrt{3}$ -circuit

Start only by connecting the mains voltage, terminals X1-X2 bridged

Application Example

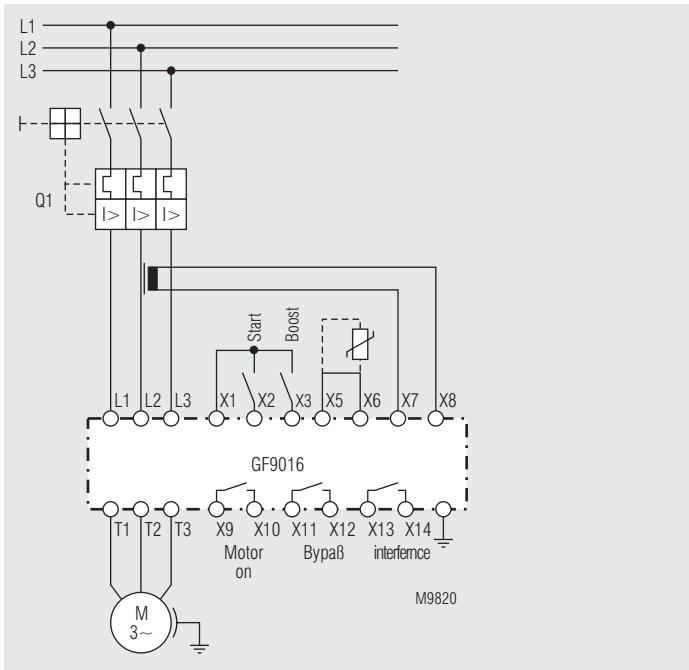

Softstart and softstop function from 25 kW with controlled current on start up.