



Brand of NTN Group

Technical data

SUCF212CO

Bearing units



Stainless steel cast housing, stainless steel insert ball bearing with socket set screws, seal with slinger, food grease

KIT CONTENT

SUC212, SCO212-60, SF212N

VISUAL (S)

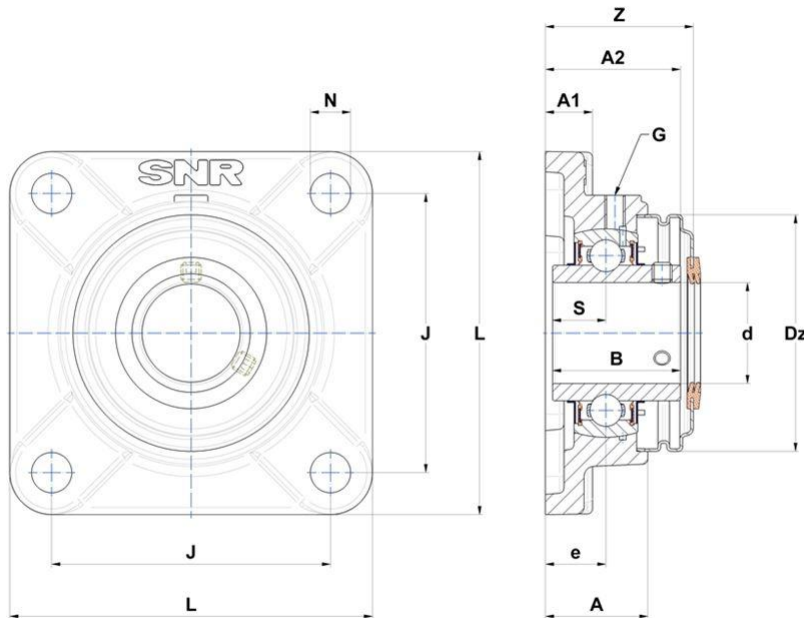

PRODUCT DEFINITION

Brand	SNR
A - Housing height	48 mm
A1 - Housing foot height / flange height	20 mm
A2 - Total height from mounting surface	68,7 mm
B - Width of Inner Ring	65,1 mm



NTN Europe

1 rue des Usines · BP 2017 · 74010 Annecy Cedex · France · Tel. +33 (0)4 50 65 30 00
S.A. au capital de 322 639 919 € · RCS ANNECY B 325 821 072 · Id. Fiscale : FR 48 325 821 072
SIRET 325 821 072 00015 · Code APE 2815 Z · Code NACE 28.15

PRODUCT DEFINITION

d - Shaft diameter	60 mm
Dz - Outer diameter of cover	120 mm
e - Distance mounting surface to bearing center	29 mm
G - Grease fitting	M6x1
J - Mounting holes distance	143 mm
L - Housing width / diameter	175 mm
N - Mounting hole dimension	19 mm
S - Distance front side/bearing centre	25,4 mm
Z - Width over covers	73,6 mm

PRODUCT PERFORMANCE

C - Dynamic load rating	52400000 mN
C0 - Static load rating	35900000 mN
Operating temperature min.	253,15 °K
Operating temperature max.	373,15 °K

OTHER FEATURES

Mass	5,823 kg
Recommended tightening torque for set screw	18.7 N-m

