



Operational characteristics

Rated operational voltage	V	24VDC
Rated current (I _n)	A	≤5A
Mechanical operation	cycles/h	120
Average closing time	ms	350
Average opening time	ms	230
Power consumption	W	14

Mechanical features

Weight	g	1300
--------	---	------

Operations

Mechanical life	cycles	25000
-----------------	--------	-------

Dimensions

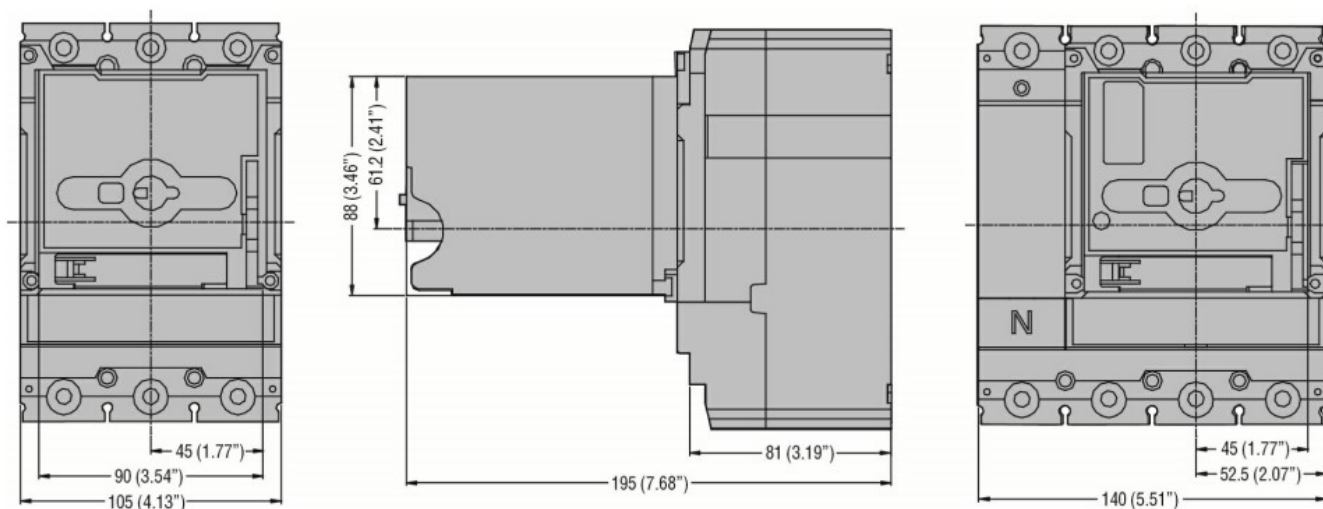

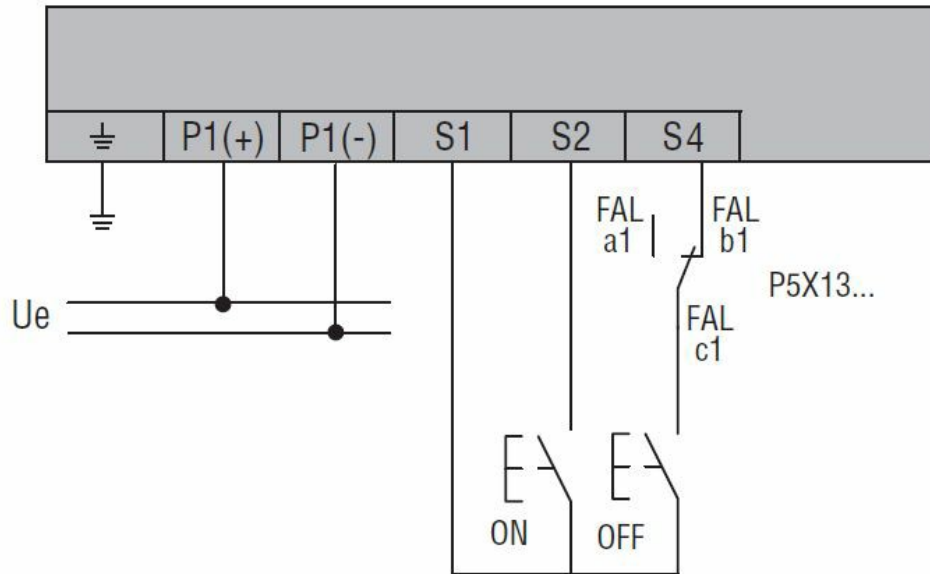

Note: Connect an NC contact of an alarm switch contact block in series with S4 to prevent remote closing of the MCCB after tripping due to overcurrent or short circuit.

Wiring diagrams

Certifications and compliance

Certificates

ETIM classification

EC000066 - Power contactor, AC switching