

R22 Ø 22 mm • Planetary Gearbox • 0.6 Nm

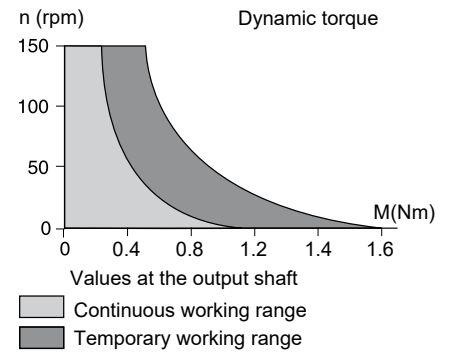
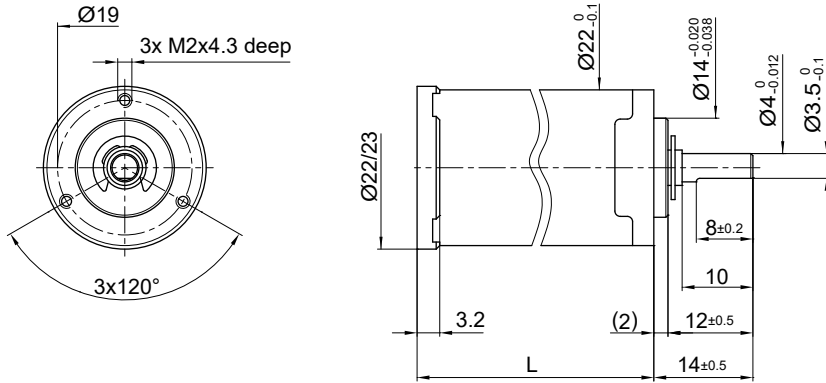

Dimensions in mm.

Ratio	5.75	16.2	19.4	27.6	33.1	65.5	93.2	111	132	159	190	376	641	1090
1 Number of Gear Stages	1	2	2	2	2	3	3	3	3	3	3	4	4	4
2 Direction of Rotation	=	=	=	=	=	=	=	=	=	=	=	=	=	=
3 Efficiency	0.8	0.7	0.7	0.7	0.7	0.6	0.6	0.6	0.6	0.6	0.6	0.5	0.5	0.5
4 L (mm)	25	32.5	32.5	32.5	32.5	40	40	40	40	40	40	40	40	40
5 Weight	g (oz)	20 (0.705)	25 (0.881)	25 (0.881)	25 (0.881)	30 (0.881)	30 (1.058)	30 (1.058)	30 (1.058)	30 (1.058)	30 (1.058)	33 (1.164)	33 (1.164)	33 (1.164)

6 Available with Motor – L2 - Length with motor (mm)														
22S78	51	58.5	58.5	58.5	58.5	66	66	66	66	66	66	66	66	66
22N78	57	64.5	64.5	64.5	64.5	72	72	72	72	72	72	72	72	72
23GST82	60.1	67.6	67.6	67.6	67.6	75.1	75.1	75.1	75.1	75.1	75.1	75.1	75.1	75.1
26N58	68.3	75.8	75.8	75.8	75.8	83.3	83.3	83.3	83.3	83.3	83.3	83.3	83.3	83.3
26N48	67.1	74.6	74.6	74.6	74.6	82.1	82.1	82.1	82.1	82.1	82.1	82.1	82.1	82.1
28L18/28	68.5	76	76	76	76	83.5	83.5	83.5	83.5	83.5	83.5	83.5	83.5	83.5
28LT12	66.2	73.7	73.7	73.7	73.7	81.2	81.2	81.2	81.2	81.2	81.2	81.2	81.2	81.2
P310	42.4	49.9	49.9	49.9	49.9	57.4	57.4	57.4	57.4	57.4	57.4	57.4	57.4	57.4
22DCP/22DCT/24DCT	55*	62.5	62.5	62.5	62.5	70	70*	70	70	70	70	70	70	70
22ECP35 / 22ECT35	60	67.5	67.5	67.5	67.5	75	75	75	75	75	75	75	75	75
22ECP45	70	77.5	77.5	77.5	77.5	85	85	85	85	85	85	85	85	85
22ECT48	73	80.5	80.5	80.5	80.5	88	88	88	88	88	88	88	88	88
22ECP60 / 22ECT60	85	92.5	92.5	92.5	92.5	100	100	100	100	100	100	100	100	100
22ECT82	107	114.5	114.5	114.5	114.5	122	122	122	122	122	122	122	122	122

Characteristics	Unit	R22 • 0 •	R22 2R • 0 •
7 Shaft Bearings		Sleeve	Ball Bearing
8 Maximum Static Torque	Nm (oz-in)	2 (283)	2 (283)
9 Maximum Radial Force @ 8mm from mounting face	N (lb)	10 (2.2)	15 (3.3)
10 Maximum Axial Force	N (lb)	10 (2.2)	10 (2.2)
11 Maximum Press Fit Force	N (lb)	300 (67.4)	300 (67.4)
12 Average Backlash @ no-load		1.5°	1.5°
13 Average Backlash @ 0.3 Nm		3°	3°
Shaft Play:			
14 -radial	µm	≤ 25	≤ 10
15 -axial	µm	50-150	50-150
16 Maximum Recommended Input Speed	rpm	5,000	5,000
17 Operating Temperature Range:	°C (°F)	-30 to +65 (-22 to +150)	

