

THIS DRAWING IS UNPUBLISHED. RELEASED FOR PUBLICATION
 © COPYRIGHT - By - ALL RIGHTS RESERVED.

LOC	DIST	REVISIONS					
GP	00	P	LTR	DESCRIPTION	DATE	DWN	APVD
			K1	REVISED PER ECO-11-004835	11MAR11	RK	HMR

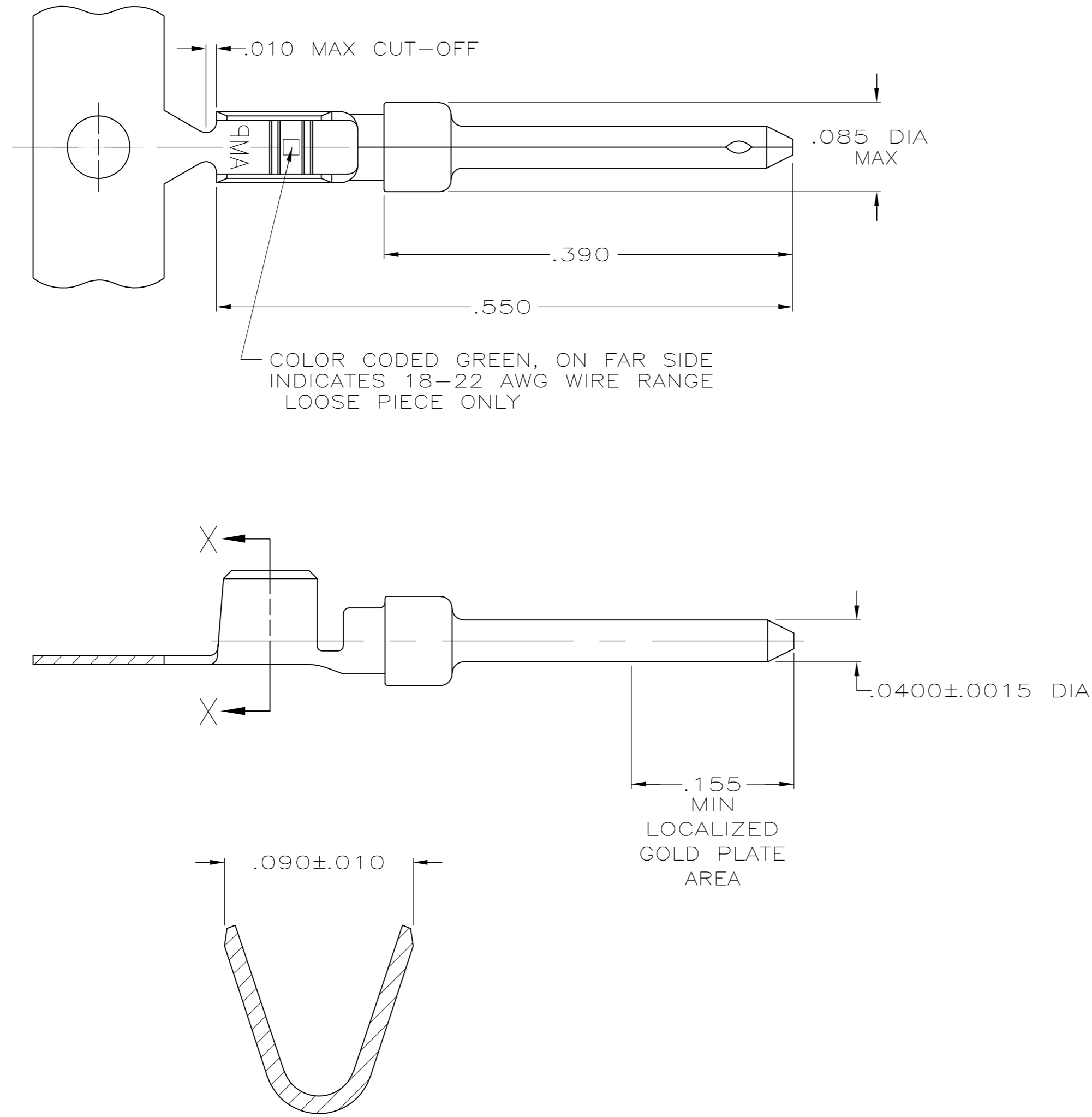

SECTION X-X
 WIRE BARREL
 SCALE 20:1

- 1 FOR MINI-APPLICATOR.
- 2 FOR HAND TOOL USE ONLY.
- 3. WIRE RANGE OF 18-22 AWG.
- 4. .068 MAX INSULATION DIAMETER ALLOWABLE WHEN USING 91067-2 EXTRACTION TOOL.
- 5. GOLD PLATING MAY NOT APPEAR ON CARRIER STRIP.
- 6 GOLD PLATING PER MIL-G-45204.
 NICKEL PLATING PER QQ-N-290.
 TIN PLATING PER MIL-T-10727.
- 7 GOLD PLATED IN LOCALIZED GOLD PLATE AREA AS FOLLOWS:
 .000030 MIN GOLD IN MATED AREA,
 GOLD FLASH ON REMAINDER OF CONTACT, ALL OVER .000050
 MIN NICKEL UNDERPLATE.
 OR
 GOLD FLASH OVER
 PALLADIUM-NICKEL PLATE, .000030 MIN TOTAL IN MATED AREA,
 GOLD FLASH ON REMAINDER OF CONTACT, ALL OVER
 .000050 MIN NICKEL UNDERPLATE.
- 8 PLATED WITH GOLD FLASH OVER
 .000030 MIN NICKEL.
- 9 PLATED WITH GOLD FLASH IN LOCALIZED GOLD PLATE AREA,
 TIN PLATED WIRE BARREL, OVER
 .000030 NICKEL.
- 10 GOLD PLATED IN LOCALIZED GOLD PLATE AREA
 .000030 GOLD IN MATED AREA,
 TIN PLATED WIRE BARREL, OVER
 .000050 NICKEL.
- 11 OBSOLETE.
- 12 SUPERSEDED BY 745229-4

10	11-745229-3	11-745229-1
9	11-745229-0	11-745229-8
8	745229-7	745229-5
7	745229-4	745229-2
FINISH	LOOSE PIECE 2	PART NUMBER 1

DIMENSIONS:		TOLERANCES UNLESS OTHERWISE SPECIFIED:		DWN		S.WELDON		9-9-86		
INCHES		0 PLC	± -	CHK	C.RICHARD	9-9-86				
		1 PLC	± -	APVD	V.KUMAR	9-10-86				
		2 PLC	± -	PRODUCT SPEC						
		3 PLC	± .005	APPLICATION SPEC	114-10000					
		4 PLC	± -	WEIGHT	-		SIZE	CAGE CODE	DRAWING NO	RESTRICTED TO
		ANGLES	± -	CUSTOMER DRAWING			A2	00779	C-745229	-
MATERIAL	BRASS PER MIL-C-50	FINISH	SEE TABLE	SCALE	10:1	SHEET	1 of 1	REV	K1	