

SERIES 48M - 19MM PANEL SEALED METAL ELECTRO-MECHANICAL

Built on the proven series 48 platform these rugged switches come in stainless steel or chrome plated housings with either momentary or maintained action and lighted or unlighted versions. The variety of options in this compact package size make the 48M ideal for many applications.



APPLICATIONS:

- Outdoor Controls
- Security Equipment
- Medical Equipment
- Food Processing Equipment
- Military Equipment
- Industrial Machinery
- Transportation: Mass-Transit, Lift Trucks

KEY FEATURES:

- Momentary or Maintained Action
- Stainless Steel Housing
- Center Spot or Ring Illumination
- Variety of LED colors
- Electro-Mechanical
- Panel Sealed to IP67
- ROHS Compliant
- Gold Plated Contact and Terminals

ORDERING INFORMATION:

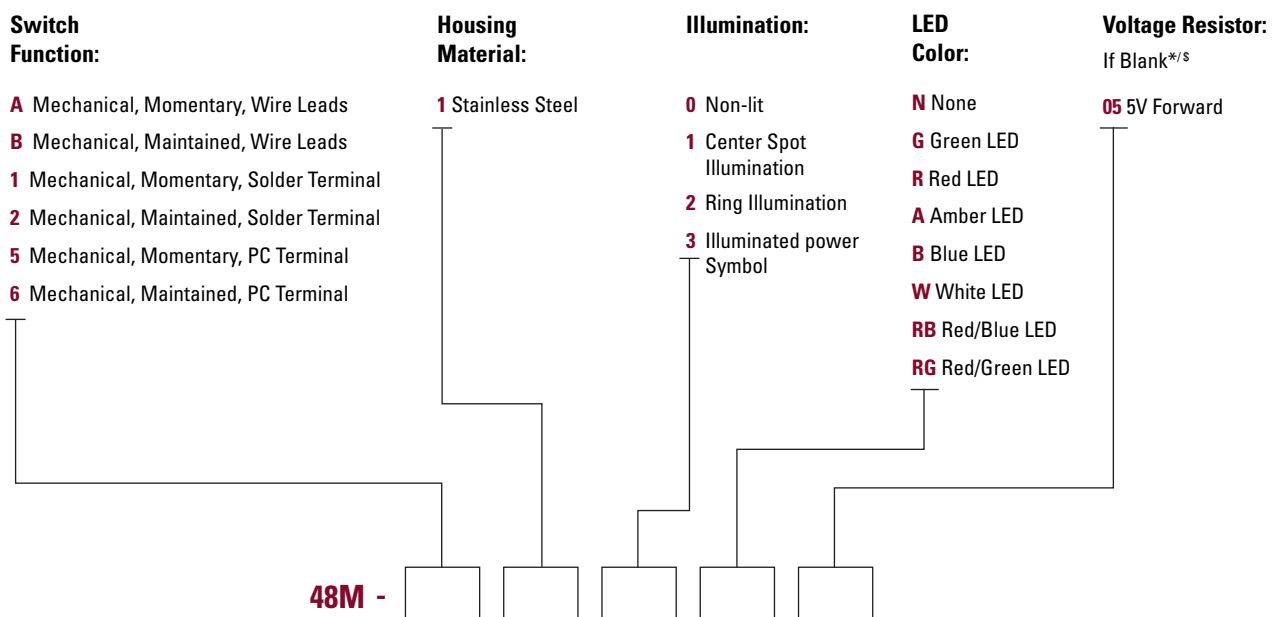

* Current limiting resistor is required to limit LED forward current to 20 mA (not included).

§ Other integrated LED voltages can be provided upon request depending on project volume

PRODUCT DRAWINGS

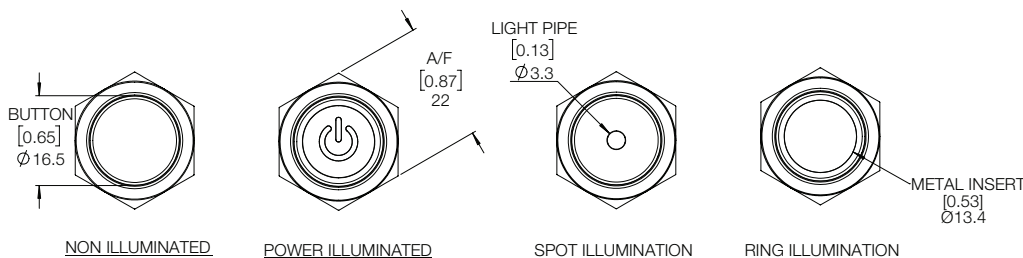
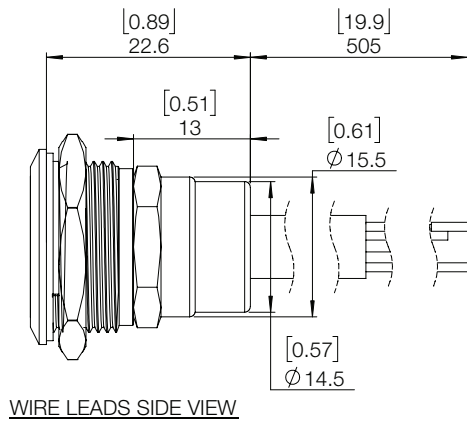
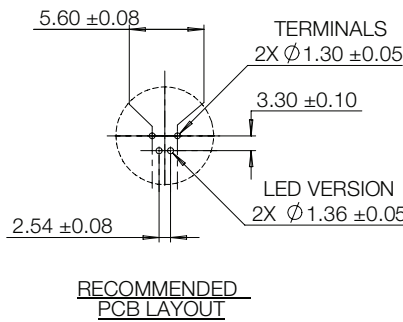
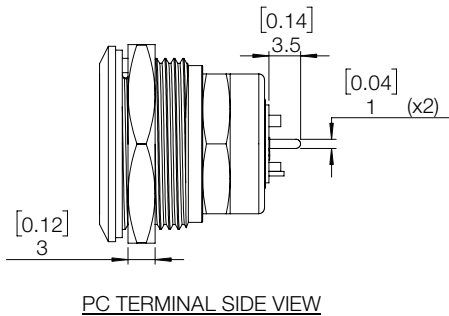
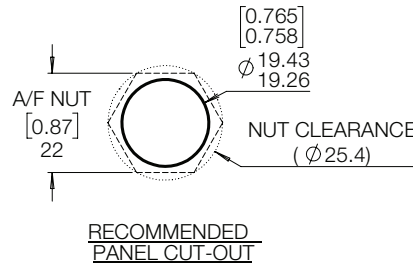
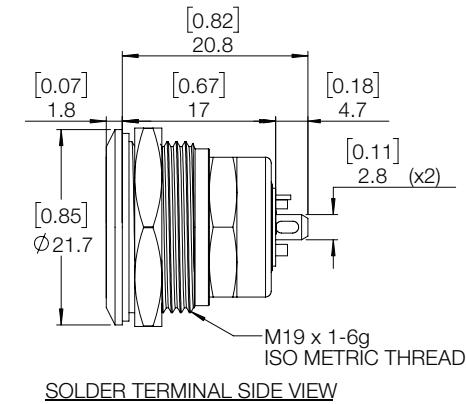

MECHANICAL CHARACTERISTICS:

- Circuit:** SPST-NO-DB (FORM X)
- Button travel (nominal):** [2.3] .09
- Operating force (nominal):** [3N] 306g
- Panel thickness:** [0.5 to 4.5] .02 to .18
- Nut torque (max):** [11.5 kgf/cm] 10 lb/in
- Hardware:** Bulk packaged sealing washer and hex nut are included

ENVIRONMENTAL SPECIFICATIONS

- Actuator ingress protection:** IP67
- Operating temperature:** Non-Lit: [-40°C to +85°C] -40°F to +185°F
- Illuminated:** [-25°C to +85°C] -13°F to +185°F

ELECTRICAL SPECIFICATIONS

- Current rating (resistive):** 250mA @ 12VDC, 100K Cycles; 150mA @ 28VDC, 150K Cycles (Momentary); 100mA @ 48VDC, 100K Cycles; 10mA @ 12VDC, 1 Million Cycles (Momentary)
- Dielectric strength:** 1,000 VAC
- Insulation resistance:** 1GΩ
- Contact resistance:** 50mΩ
- Wire leads:** UL STYLE 1007; 26 AWG, Stranded