

# Spherical roller bearings, cylindrical and tapered bore

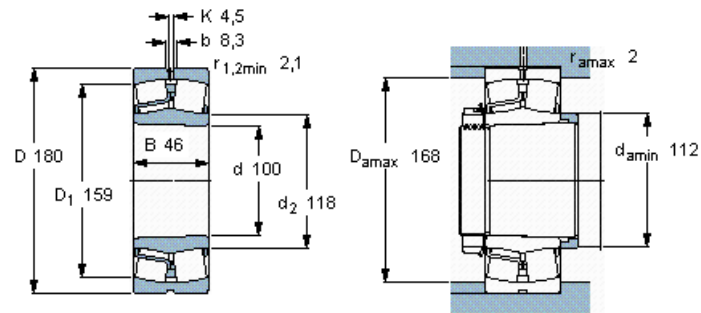

Principal dimensions			Basic load ratings		Fatigue load limit $P_u$	Speed ratings		Mass	Designation
d	D	B	dynamic	static		Reference speed	Limiting speed		
mm			C	$C_0$	kN	r/min	kg	-	* - SKF Explorer bearing
100	180	46	425	490	49	3400	4,80	22220 EK *	



Tapered bore, taper  
1: 12

### Calculation factors

e 0,24  
 $Y_1$  2,8  
 $Y_2$  4,2  
 $Y_0$  2,8