

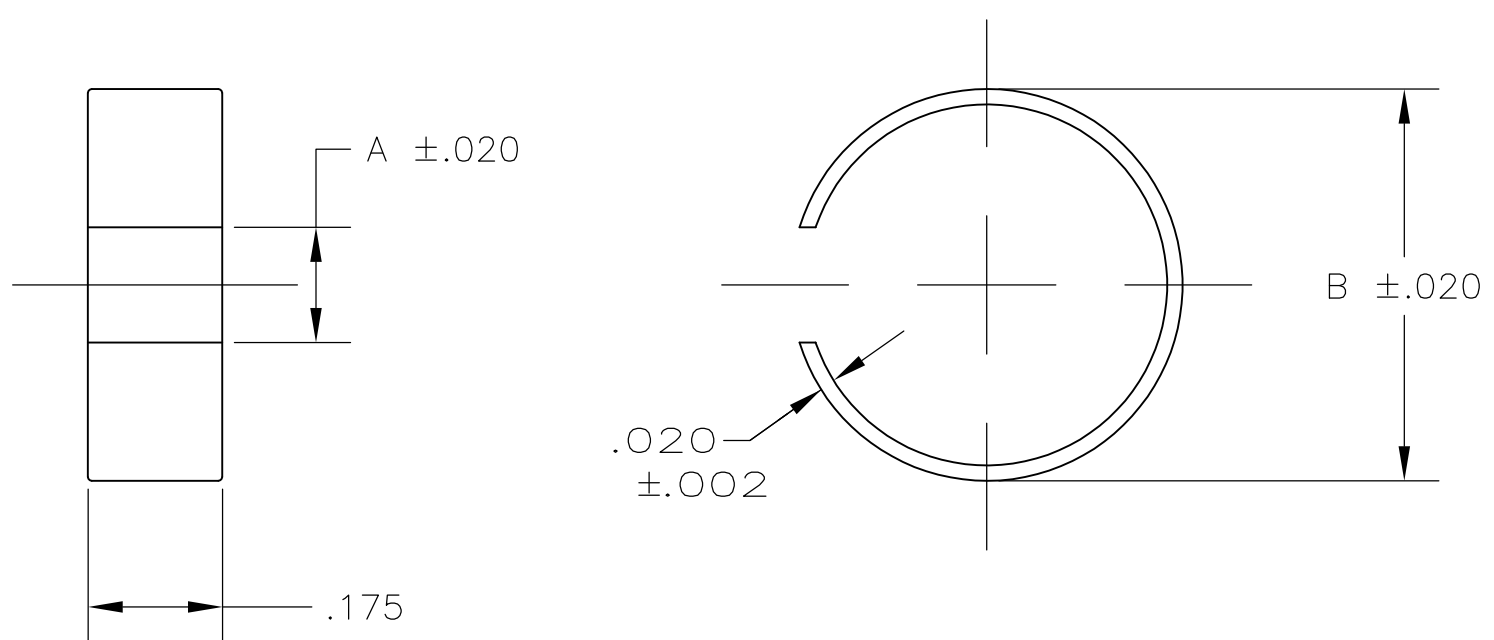

THIS DRAWING IS UNPUBLISHED. RELEASED FOR PUBLICATION
 © COPYRIGHT - By - ALL RIGHTS RESERVED.

LOC	DIST	REVISIONS					
GP	00	P	LTR	DESCRIPTION	DATE	DWN	APVD
				C1 REVISED PER ECO-11-005033	23MAR11	RK	HMR

FERRULE SELECTION PROCEDURE:
 A. SELECT THE DESIRED CABLE CLAMP FROM ANY OF THE FOLLOWING DRAWINGS:
 5745171, 5745172, 5745173, 5745174, 5745175, 5745854, 5747099,
 5745833, 5747100, 5747098, 5745919, 5745652, 5745653
 B. VERIFY THAT THE CHOSEN CABLE CLAMP IS AVAILABLE.
 C. SELECT A SPLIT RING FERRULE PART NUMBER TO MATCH THE CABLE
 CLAMP SIZE AND CABLE DIAMETER TO BE USED.
 D. SEE INNER FERRULES ON DRAWING 745129 FOR ADDITIONAL OPTIONS.

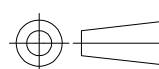

5	.710-.750	0.790	0.220	1-745508-2
4, 5	.635-.675	0.690	0.200	1-745508-1
4, 5	.560-.600	0.620	0.180	1-745508-0
3, 5	.490-.530	0.550	0.180	745508-9
3, 4	.460-.500	0.510	0.150	745508-8
5	.410-.450	0.470	0.150	745508-7
1, 2, 5	.335-.375	0.390	0.130	745508-6
3, 4	.310-.350	0.370	0.120	745508-5
2, 3	.260-.300	0.310	0.100	745508-4
1, 2	.185-.225	0.260	0.080	745508-3
1	.160-.200	0.220	0.060	745508-2
2, 3, 4	.390-.430	0.450	0.150	745508-1
FOR CABLE CLAMP SIZE(S)	CABLE DIA RANGE	B	A	PART NUMBER

THIS DRAWING IS A CONTROLLED DOCUMENT.		DWN	B. MCMASTER	12MAR04	 TE Connectivity
DIMENSIONS: INCHES		CHK	C. ROHDE	12MAR04	
		APVD	M. WALMSLEY	12MAR04	
TOLERANCES UNLESS OTHERWISE SPECIFIED: 0 PLC ± - 1 PLC ± - 2 PLC ± - 3 PLC ± .010 4 PLC ± - ANGLES ± -		PRODUCT SPEC	NAME		
MATERIAL	ALUMINUM	FINISH	-		FERRULE, CABLE CLAMP, SPLIT RING
CUSTOMER DRAWING		WEIGHT	-		SIZE
		A300779		C-745508	CAGE CODE
		SCALE 4:1		SHEET 1 OF 1	RESTRICTED TO
				REV C1	