

543916 DGSL-6-10-PA Mini slide - Series: All

DGSL-6-10-PA/P1A/EA

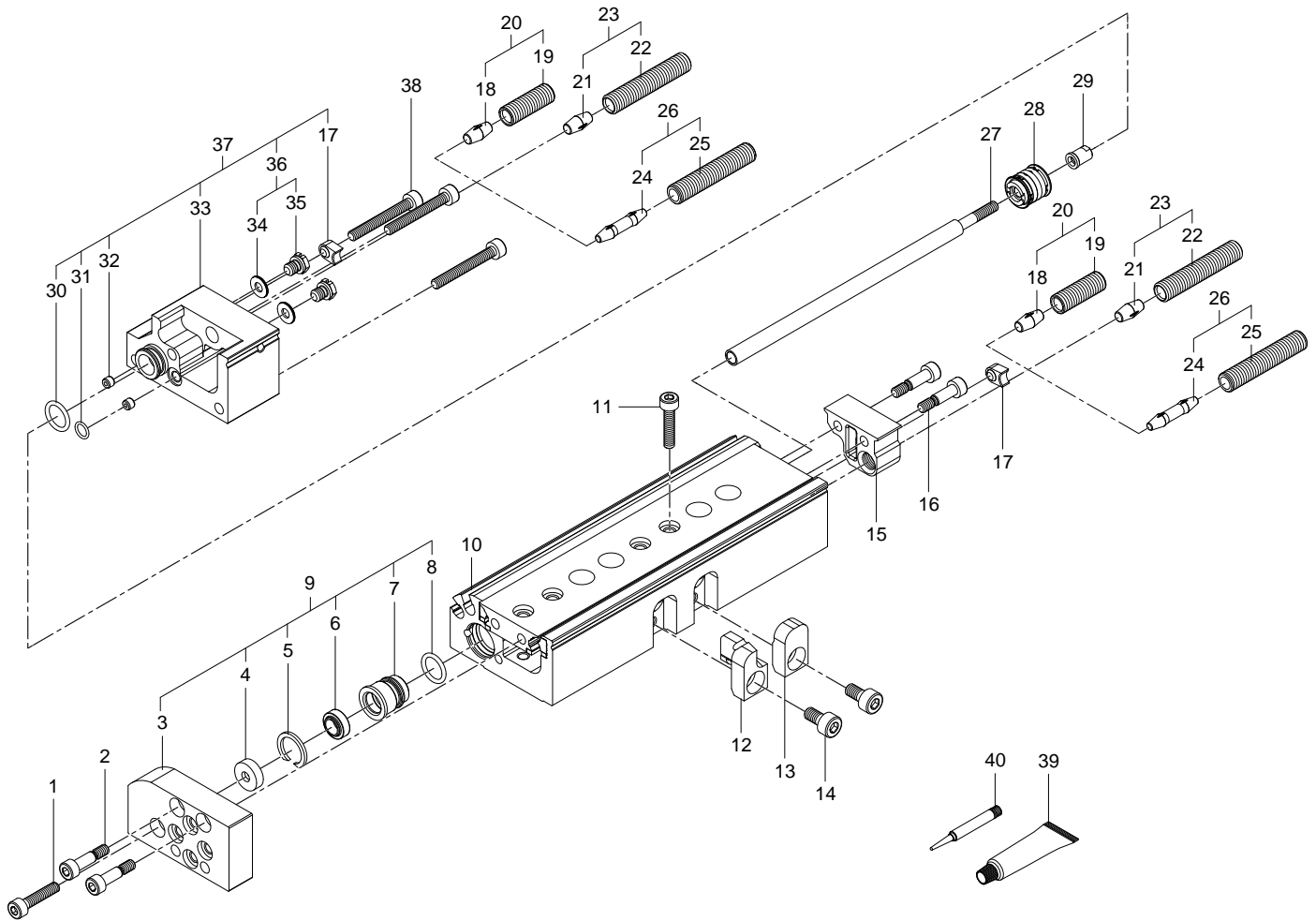

## 543916 DGSL-6-10-PA Mini slide - Series: All

DGSL-6-10-PA/P1A/EA

Pos.	Part no.	Type	Note	Qty.	Unit
A	713744	DGSL-6-...- Set of wearing parts	Spare parts: 5, 6, 8, 11, 18, 21, 24, 28, 29, 30, 31, 34, 39, 40	1	PC
1		ISO 4762-M2,5X8-12.9 Socket head screw	Not available Tightening torque 0.76 Nm / 0.6 lbf ft	1	PC
2	679833	DGSL-6 Shaft screw	Tightening torque 0.76 Nm / 0.6 lbf ft	2	PC
3		DGSL-6 Yoke plate	Not available separately, see position 9 Glue with Loctite 401, adhesion surface area must free of oil and grease Warning! Disassembly requires recalibration.	1	PC
4		DGSL-6 Sleeve	Not available separately, see position 9 Glue with Loctite 401, adhesion surface area must free of oil and grease Warning! Disassembly requires recalibration.	1	PC
5		SB-9 Circlip	Not available separately, see position 9	1	PC
6		WIFC1-4X7X2,8-NBR Wiper seal	Not available separately, see position 9+999 Grease using during assembly. See position 39	1	PC
7		DGSL-6 Bearing cap	Not available separately, see position 9 Grease using during assembly. See position 39	1	PC
8		B-6X1-N-NBR75 O-ring ISO3601	Not available separately, see position 9+999 Grease using during assembly. See position 39	1	PC
9	8197187	DGSL-6 Set of components		1	PC
10		DGSL-6-10 Guide module	Not available Use locking compound. See position 40	1	PC
11	207726	ISO 4762-M3X20-8.8 Socket head screw		1	PC
12	686783	DGSL-6 Stop		1	PC
13	686799	DGSL-6 Covering		1	PC
14	207275	ISO 4762-M3X6-8.8 Socket head screw	Tightening torque 1.3 Nm / 1.0 lbf ft	1	PC
15	684370	DGSL-6 Moment compensator		1	PC
16		ISO 4762-M2,5X12-12.9 Socket head screw	Not available Tightening torque 0.76 Nm / 0.6 lbf ft	2	PC
17	699252	DGSL-6 Clamping component	Use locking compound. See position 40	2	PC
18	686822	DGSL-6-PJ Buffer element		1	PC
19		DYEF-S-M5-Y1 adjustment sleeve	Not available separately, see position 20	1	PC
20	1152507	DYEF-S-M5-Y1 Shock absorber	shock absorber -E	2	PC
21	686822	DGSL-6-PJ Buffer element		1	PC
22		DGSL-6-P adjustment sleeve	Not available separately, see position 23	1	PC
23	1179818	DYEF-M5-Y1 Shock absorber	shock absorber -P	2	PC
24	683972	DYEF-M5-Y1F Buffer		1	PC

Pos.	Part no.	Type	Note	Qty.	Unit
25		DGSL-6-P1 adjustment sleeve	Not available separately, see position 26	1	PC
26	548371	DYEF-M5-Y1F Shock absorber	shock absorber -P1	2	PC
27	685375	IRA-04-S0037,3-B Piston rod	Glue with Loctite 401, adhesion surface area must free of oil and grease Warning! Disassembly requires recalibration.	1	PC
28		BA-K10D-008-A Complete piston	Not available separately, see position A Grease using during assembly. See position 39	1	PC
29	709438	DSNU- 8/10 Nut	Tightening torque 0.35 Nm / 0.3 lbf ft Use locking compound. See position 40	1	PC
30		B-6X1-N-NBR75 O-ring ISO3601	Not available separately, see position A Grease using during assembly. See position 39	1	PC
31		3,3X0,6-S-NBR75 O-ring	Not available separately, see position A Grease using during assembly. See position 39	1	PC
32		DGSL-6 Flow control plate	Not available separately, see position 37	2	PC
33		DGSL-6 Connection cap	Not available separately, see position 37	1	PC
34		OK-M3 Sealing ring	Not available separately, see position A	2	PC
35		B-M3-S9 Plug screw	Not available separately, see position 36 Tightening torque 0.5 Nm / 0.4 lbf ft	2	PC
36	712004	B-M3-S9-OK Blanking plug		2	PC
37	714228	DGSL- 6-...-ET Connection cover module		1	PC
38	653327	ISO 4762-M2,5X20-12.9 Socket head screw	Tightening torque 0.76 Nm / 0.6 lbf ft Use locking compound. See position 40	3	PC
39	684474	LUB-KC1 SILIKONFREI 20ML Lubricating grease		1	PC
40	8181256	CYBERBOND TM44 TB1ML Adhesive bonding agent		1	PC