

# Spherical roller bearings, cylindrical and tapered bore

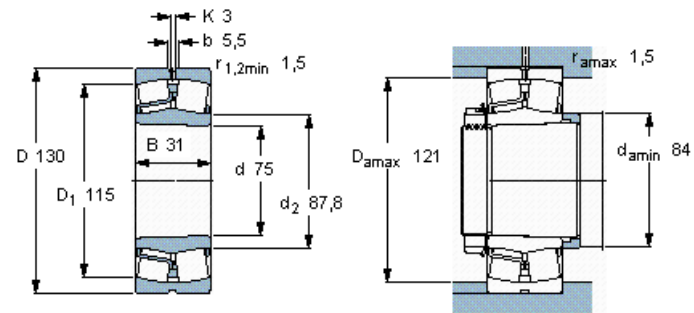

Principal dimensions			Basic load ratings		Fatigue load limit $P_u$	Speed ratings		Mass	Designation
d	D	B	dynamic	static		Reference speed	Limiting speed		
mm			C	$C_0$	kN	r/min	kg	-	* - SKF Explorer bearing
75	130	31	212	240	26,5	4800	6300	1,65	22215 EK *



Tapered bore, taper  
1: 12

### Calculation factors

- e 0,22
- $Y_1$  3
- $Y_2$  4,6
- $Y_0$  2,8