

R-RBP Rawlbolt® - Bolt Projecting for use in cracked and non-cracked concrete

World's most popular all-purpose expanding shield anchor - bolt projecting version

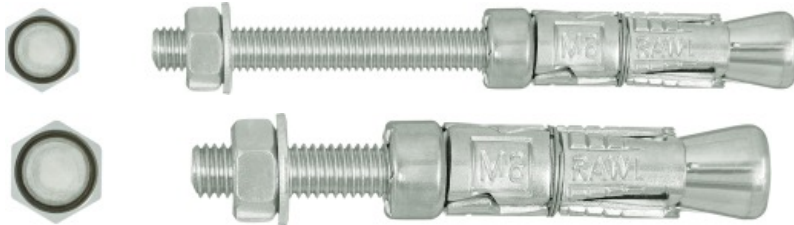

Approvals and Reports

- ETA-11/0479



Product information

Features and benefits

- RAWLBOLT® - first ever mechanical anchor in the world, forerunner of all of the later mechanical anchors
- For use in cracked and non-cracked concrete (ETA option 1), hollow-core slabs, flooring blocks and ceramics
- Product recommended for applications requiring fire resistance
- Three-pieces expanding sleeve of maximum expansion provides optimal load and safety of use in any substrate
- Wide range of diameters (M6 to M20)

Applications

- Roller shutter doors
- Fire doors
- Steelwork
- Security grills
- Heavy machinery
- Pipework/duct work support

Base materials

Approved for use in:

- Cracked concrete C20/25-C50/60
- Non-cracked concrete C20/25-C50/60
- Unreinforced concrete
- Reinforced concrete

Also suitable for use in:

- Solid clay brick $\geq 20\text{MPa}$
- Hollow Lightweight Concrete Block LAC $5 \geq 5\text{MPa}$
- Hollow Sand-lime Brick $\geq 15\text{MPa}$
- Concrete hollow floor block (eg. Teriva)
- Hollow-core Slab C20/25
- Hollow-core Slab C30/37-C50/60

Installation guide



1. Drill a hole of required diameter and depth. Note: When fixing into brickwork, mortar joints should be avoided
2. Clear the hole of drilling dust and debris (using blowpump or equivalent method)
3. Remove nut and washer and insert anchor into hole. Tap home with hammer until flush with surface
4. Position fixture over the projecting bolt
5. Add washer and nut and tighten to recommended torque

Product information

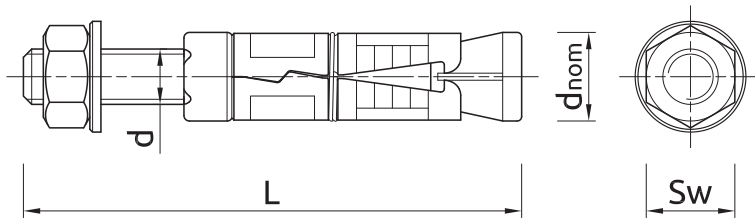

Size	Product Code	Approval type	Anchor			Fixture	
			Diameter	External diameter	Length	Max. thickness	Hole diameter
			d [mm]	d_{nom} [mm]	L [mm]	t_{fix} [mm]	d_f [mm]
M6	R-RBP-M06/10W	ETA-11/0479	6	12	65	10	6,5
	R-RBP-M06/25W	ETA-11/0479	6	12	80	25	6,5
	R-RBP-M06/60W	ETA-11/0479	6	12	115	60	6,5
M8	R-RBP-M08/10W	ETA-11/0479	8	14	75	10	9
	R-RBP-M08/25W	ETA-11/0479	8	14	90	25	9
	R-RBP-M08/60W	ETA-11/0479	8	14	125	60	9
M10	R-RBP-M10/15W	ETA-11/0479	10	16	90	15	11
	R-RBP-M10/30W	ETA-11/0479	10	16	105	30	11
	R-RBP-M10/60W	ETA-11/0479	10	16	135	60	11
M12	R-RBP-M12/15W	ETA-11/0479	12	20	110	15	13
	R-RBP-M12/30W	ETA-11/0479	12	20	125	30	13
	R-RBP-M12/75W	ETA-11/0479	12	20	170	75	13
M16	R-RBP-M16/15W	ETA-11/0479	16	25	150	15	17
	R-RBP-M16/35W	ETA-11/0479	16	25	170	35	17
	R-RBP-M16/75W	ETA-11/0479	16	25	210	75	17
M20	R-RBP-M20/15W	ETA-11/0479	20	32	170	15	22
	R-RBP-M20/30W	ETA-11/0479	20	32	185	30	22
	R-RBP-M20/100W	ETA-11/0479	20	32	255	100	22
M24	R-RBP-M24/75W	-	24	38	255	75	26
	R-RBP-M24/150W	-	24	38	300	150	26

Installation data

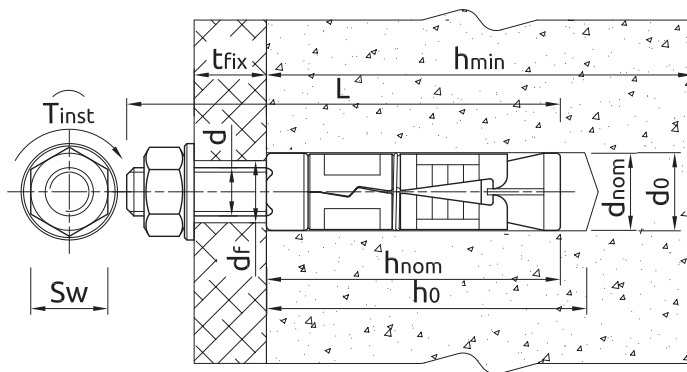

Installation data

Size			M6	M8	M10	M12	M16	M20	M24
Thread diameter	d	[mm]	6	8	10	12	16	20	24
Hole diameter in substrate	d ₀	[mm]	12	14	16	20	25	32	38
Installation torque	T _{inst}	[Nm]	6.5	15	27	50	120	230	400
Wrench size	Sw	[mm]	10	13	17	19	24	30	24
Min. hole depth in substrate	h ₀	[mm]	50	55	65	85	125	140	160
Min. installation depth	h _{nom}	[mm]	45	50	60	80	120	135	155
Min. substrate thickness	h _{min}	[mm]	100	100	100	100	142.5	172.5	240
Min. spacing	s _{min}	[mm]	35	40	50	60	95	115	210
Min. edge distance	c _{min}	[mm]	53	60	75	90	143	173	188

Mechanical properties

Size			M6	M8	M10	M12	M16	M20	M24
Nominal ultimate tensile strength - tension	F _{uk}	[N/mm ²]	500	500	500	500	500	500	500
Nominal yield strength - tension	F _{yk}	[N/mm ²]	400	400	400	400	400	400	400
Cross sectional area - tension	A _s	[mm ²]	20.1	36.6	58	84.3	157	245	353
Elastic section modulus	W _{el}	[mm ³]	21.21	50.27	98.17	169.65	402.12	785.4	1357.17
Characteristic bending resistance	M ⁰ _{Rk,s}	[Nm]	12.72	30.16	58.9	101.79	241.27	471.24	814.3
Design bending resistance	M	[Nm]	10.18	24.13	47.12	81.43	193.02	376.99	651.44

Basic performance data

Performance data for single anchor without influence of edge distance and spacing - ETAG 001

Size		M6	M8	M10	M12	M16	M20	M24
MEAN ULTIMATE LOAD								
TENSION LOAD N_{Ru,m}								
NON-CRACKED CONCRETE	[kN]	6.36	8.35	15.24	18.48	48.77	56.55	94.30
CRACKED CONCRETE	[kN]	4.06	5.31	7.12	12.01	18.24	34.16	-
SHEAR LOAD V_{Ru,m}								
NON-CRACKED CONCRETE	[kN]	6.04	10.98	17.40	25.30	47.10	73.50	105.90
CRACKED CONCRETE	[kN]	6.04	10.98	17.40	25.30	47.10	73.50	-
CHARACTERISTIC LOAD								
TENSION LOAD N_{Rk}								
NON-CRACKED CONCRETE	[kN]	6.00	7.50	12.00	16.00	40.00	50.00	70.00
CRACKED CONCRETE	[kN]	4.00	5.00	6.00	12.00	16.00	30.00	-
SHEAR LOAD V_{Rk}								
NON-CRACKED CONCRETE	[kN]	5.03	9.15	14.50	21.08	39.25	61.25	88.30
CRACKED CONCRETE	[kN]	5.03	9.11	12.73	21.08	39.25	61.25	-
DESIGN LOAD								
TENSION LOAD N_{Rd}								
NON-CRACKED CONCRETE	[kN]	3.33	4.17	6.67	8.89	22.22	27.78	38.90
CRACKED CONCRETE	[kN]	2.22	2.78	3.33	6.67	8.89	16.67	-
SHEAR LOAD V_{Rd}								
NON-CRACKED CONCRETE	[kN]	4.02	7.32	11.60	16.86	31.40	49.00	70.60
CRACKED CONCRETE	[kN]	4.02	7.32	10.61	16.86	31.40	49.00	-
RECOMMENDED LOAD								
TENSION LOAD N_{rec}								
NON-CRACKED CONCRETE	[kN]	2.38	2.98	4.76	6.35	15.87	19.84	27.80
CRACKED CONCRETE	[kN]	1.59	1.99	2.38	4.76	6.35	11.91	-
SHEAR LOAD V_{rec}								
NON-CRACKED CONCRETE	[kN]	2.87	5.23	8.29	12.05	22.43	35.00	50.40
CRACKED CONCRETE	[kN]	2.87	5.23	7.58	12.05	22.43	35.00	-

Basic performance data

Design performance data

Size			M6	M8	M10	M12	M16	M20	M24
Effective embedment depth	h_{ef}	[mm]	35.00	40.00	50.00	60.00	95.00	115.00	125.00
TENSION LOAD									
STEEL FAILURE									
Characteristic resistance	$N_{Rk,s}$	[kN]	10.05	18.30	29.00	42.15	78.50	122.50	176.50
Partial safety factor	γ_{Ms}	-	1.50	1.50	1.50	1.50	1.50	1.50	1.50
PULL-OUT FAILURE; NON-CRACKED CONCRETE C20/25									
Characteristic resistance	$N_{Rk,p}$	[kN]	6.00	7.50	12.00	16.00	40.00	50.00	70.00
PULL-OUT FAILURE; CRACKED CONCRETE C20/25									
Characteristic resistance	$N_{Rk,p}$	[kN]	4.00	5.00	6.00	12.00	16.00	30.00	-
PULL-OUT FAILURE									
Installation safety factor	γ_2	-	1.20	1.20	1.20	1.20	1.20	1.20	1.40
Increasing factors for $N_{Rd,p}$ - C30/37	ψ_c	-	1.22	1.22	1.22	1.22	1.22	1.22	1.00
Increasing factors for $N_{Rd,p}$ - C40/50	ψ_c	-	1.41	1.41	1.41	1.41	1.41	1.41	1.00
Increasing factors for $N_{Rd,p}$ - C50/60	ψ_c	-	1.55	1.55	1.55	1.55	1.55	1.55	1.00
CONCRETE CONE FAILURE									
Factor for cracked concrete	k	-	7.20	7.20	7.20	7.20	7.20	7.20	-
Factor for cracked concrete	$k_{cr,N}$	-	7.70	7.70	7.70	7.70	7.70	7.70	-
Factor for non-cracked concrete	k	-	10.10	10.10	10.10	10.10	10.10	10.10	10.10
Factor for non-cracked concrete	$k_{ucr,N}$	-	11.00	11.00	11.00	11.00	11.00	11.00	11.00
Installation safety factor	γ_2	-	1.20	1.20	1.20	1.20	1.20	1.20	1.40
Spacing	$s_{cr,N}$	[mm]	105.00	120.00	150.00	180.00	285.00	345.00	375.00
Edge distance	$c_{cr,N}$	[mm]	52.50	60.00	75.00	90.00	143.00	173.00	188.00
CONCRETE SPLITTING FAILURE									
Spacing	$s_{cr,sp}$	[mm]	105.00	120.00	150.00	180.00	285.00	345.00	375.00
Edge distance	$c_{cr,sp}$	[mm]	53.00	60.00	75.00	90.00	143.00	173.00	188.00
Installation safety factor	γ_2	-	1.20	1.20	1.20	1.20	1.20	1.20	1.40
SHEAR LOAD									
STEEL FAILURE									
Characteristic resistance without lever arm	$V_{Rk,s}$	[kN]	5.03	9.15	14.50	21.08	39.25	61.25	88.30
Ductility factor	k_7	-	0.80	0.80	0.80	0.80	0.80	0.80	0.80
Characteristic resistance with lever arm	$M_{Rk,s}$	[Nm]	7.63	18.74	37.39	65.52	166.52	324.62	583.40
Partial safety factor	γ_{Ms}	-	1.25	1.25	1.25	1.25	1.25	1.25	1.25
CONCRETE PRY-OUT FAILURE									
Factor	k	-	1.00	1.00	1.00	2.00	2.00	2.00	2.00
Installation safety factor	γ_2	-	1.00	1.00	1.00	1.00	1.00	1.00	1.00
CONCRETE EDGE FAILURE									
Effective length of anchor	ℓ_f	[mm]	35.00	40.00	50.00	60.00	95.00	115.00	125.00
Anchor diameter	d_{nom}	[mm]	6.00	8.00	10.00	12.00	16.00	20.00	24.00
Installation safety factor	γ_2	-	1.00	1.00	1.00	1.00	1.00	1.00	1.00

Design performance data

Resistance to tension and shear loads under fire exposure

Size			M6	M8	M10	M12	M16	M20
TENSION LOAD								
Edge distance	C_{cr}	[mm]	70.00	80.00	100.00	120.00	190.00	230.00
Spacing	S_{cr}	[mm]	140.00	160.00	200.00	240.00	380.00	460.00
R (for EI) = 30 min								
TENSION LOAD								
STEEL FAILURE								
Characteristic resistance	$N_{Rk,s}$	[kN]	0.20	0.40	0.90	1.70	3.10	4.90
PULL-OUT FAILURE								
Characteristic resistance	$N_{Rk,p}$	[kN]	1.00	1.30	1.50	3.00	4.00	7.50
SHEAR LOAD								
STEEL FAILURE								
Characteristic resistance without lever arm	$V_{Rk,s}$	[kN]	0.20	0.40	0.90	1.70	3.10	4.90
Characteristic resistance with lever arm	$M_{Rk,s}$	[kN]	0.20	0.40	1.10	2.60	6.70	13.00
R (for EI) = 60 min								
TENSION LOAD								
STEEL FAILURE								
Characteristic resistance	$N_{Rk,s}$	[kN]	0.20	0.30	0.80	1.30	2.40	3.70
PULL-OUT FAILURE								
Characteristic resistance	$N_{Rk,p}$	[kN]	1.00	1.30	1.50	3.00	4.00	7.50
SHEAR LOAD								
STEEL FAILURE								
Characteristic resistance without lever arm	$V_{Rk,s}$	[kN]	0.20	0.30	0.80	1.30	2.40	3.70
Characteristic resistance with lever arm	$M_{Rk,s}$	[kN]	0.10	0.30	1.00	2.00	5.00	9.70
R (for EI) = 90 min								
TENSION LOAD								
STEEL FAILURE								
Characteristic resistance	$N_{Rk,s}$	[kN]	0.10	0.30	0.60	1.10	2.00	3.20
PULL-OUT FAILURE								
Characteristic resistance	$N_{Rk,p}$	[kN]	1.00	1.30	1.50	3.00	4.00	7.50
SHEAR LOAD								
STEEL FAILURE								
Characteristic resistance without lever arm	$V_{Rk,s}$	[kN]	0.10	0.30	0.60	1.10	2.00	3.20
Characteristic resistance with lever arm	$M_{Rk,s}$	[kN]	0.10	0.30	0.70	1.70	4.30	8.40
R (for EI) = 120 min								
TENSION LOAD								
STEEL FAILURE								
Characteristic resistance	$N_{Rk,s}$	[kN]	0.10	0.20	0.50	0.80	1.60	2.50
PULL-OUT FAILURE								
Characteristic resistance	$N_{Rk,p}$	[kN]	0.80	1.00	1.20	2.40	3.20	6.00
SHEAR LOAD								
STEEL FAILURE								
Characteristic resistance without lever arm	$V_{Rk,s}$	[kN]	0.10	0.20	0.50	0.80	1.60	2.50
Characteristic resistance with lever arm	$M_{Rk,s}$	[kN]	0.10	0.20	0.60	1.30	3.30	6.50

Product commercial data

Size	Product Code	Anchor		Quantity [pcs]			Weight [kg]			Bar Codes
		Diameter [mm]	Length [mm]	Box	Outer	Pallet	Box	Outer	Pallet	
M6	R-RBP-M06/10W ¹⁾	6	65	50	400	16000	1.59	12.7	538.8	5906675283593
	R-RBP-M06/25W ¹⁾	6	80	50	400	16000	1.73	13.8	582.0	5906675283616
	R-RBP-M06/60W ¹⁾	6	115	50	50	8000	2.0	2.0	354.0	5906675283630
M8	R-RBP-M08/10W ¹⁾	8	75	50	400	16000	2.9	22.9	946.8	5906675283654
	R-RBP-M08/25W ¹⁾	8	90	50	50	8000	3.1	3.1	528.4	5906675283678
	R-RBP-M08/60W ¹⁾	8	125	50	50	8000	3.7	3.7	614.8	5906675283692
M10	R-RBP-M10/15W ¹⁾	10	90	50	50	8000	5.0	5.0	825.2	5906675283715
	R-RBP-M10/30W ¹⁾	10	105	50	50	6000	5.3	5.3	666.0	5906675283739
	R-RBP-M10/60W ¹⁾	10	135	50	50	8000	6.1	6.1	998.0	5906675283753
M12	R-RBP-M12/15W ¹⁾	12	110	25	25	4000	4.6	4.6	767.2	5906675283760
	R-RBP-M12/30W ¹⁾	12	125	25	25	4000	4.9	4.9	818.4	5906675283777
	R-RBP-M12/75W ¹⁾	12	170	25	25	3000	5.8	5.8	721.8	5906675283784
M16	R-RBP-M16/15W ¹⁾	16	150	10	10	1600	4.4	4.4	733.5	5906675283791
	R-RBP-M16/35W ¹⁾	16	170	10	10	1600	4.7	4.7	773.5	5906675283807
	R-RBP-M16/75W ¹⁾	16	210	10	10	1200	5.3	5.3	662.9	5906675283814
M20	R-RBP-M20/15W ¹⁾	20	170	10	10	1200	8.0	8.0	985.1	5906675283821
	R-RBP-M20/30W ¹⁾	20	185	10	10	1200	8.3	8.3	1030.4	5906675283838
	R-RBP-M20/100W ¹⁾	20	255	10	10	1200	9.9	9.9	1219.2	5906675284781
M24	R-RBP-M24/75W	24	255	5	5	600	7.1	7.1	887.2	5906675283852
	R-RBP-M24/150W	24	300	2	2	400	3.2	3.2	672.0	5906675283845

1) ETA-11/0479