

● THESE DIMENSIONS ARE CRITICAL TO THE MECHANICAL AND ELECTRICAL PERFORMANCE OF THE CONNECTION SYSTEM.

### MATERIAL SPECIFICATIONS

**RECOMMENDED**  
 BASE METAL - CDA-210, EXTRA SPRING TEMPER  
 \* TIN PLATING (WHERE APPLICABLE TO 125°C MAX CONTINUOUS USAGE): 0.0050±0.0025 MM (200±100 μIN) ELECTROPLATED TIN.  
 \* USAGE OF PLATING TYPES OTHER THAN RECOMMENDED MUST BE APPROVED BY DELPHI PACKARD ELECTRIC SYSTEMS ENGINEERING.

**MINIMUMS**  
 ELECTRICAL CONDUCTIVITY - >28% IACS AT 20°C. USE OF A MATERIAL WITH CONDUCTIVITY <28% IACS MUST BE APPROVED BY PACKARD ELECTRIC MATERIALS ENGINEERING.  
 TENSILE STRENGTH - 430 - 480 MPa  
 UNDERPLATING FOR TIN PLATING - FOR BASE MATERIALS CONTAINING 10% OR MORE ZINC, AN UNDERPLATE OF COPPER 0.0025 MM (100 μIN) MINIMUM THICK IS REQUIRED.  
 PROCESSING LUBRICANT - ANY PROCESSING LUBRICANT REMAINING ON TERMINALS MUST NOT VARNISH OR DEGRADE THE ELECTRICAL PERFORMANCE OF THE CONNECTION UP TO A MAXIMUM TEMPERATURE OF 150°C. PROCESSING LUBRICANTS MUST BE APPROVED BY DELPHI PACKARD ELECTRIC SYSTEMS ENGINEERING.

### MATING BLADE INFORMATION

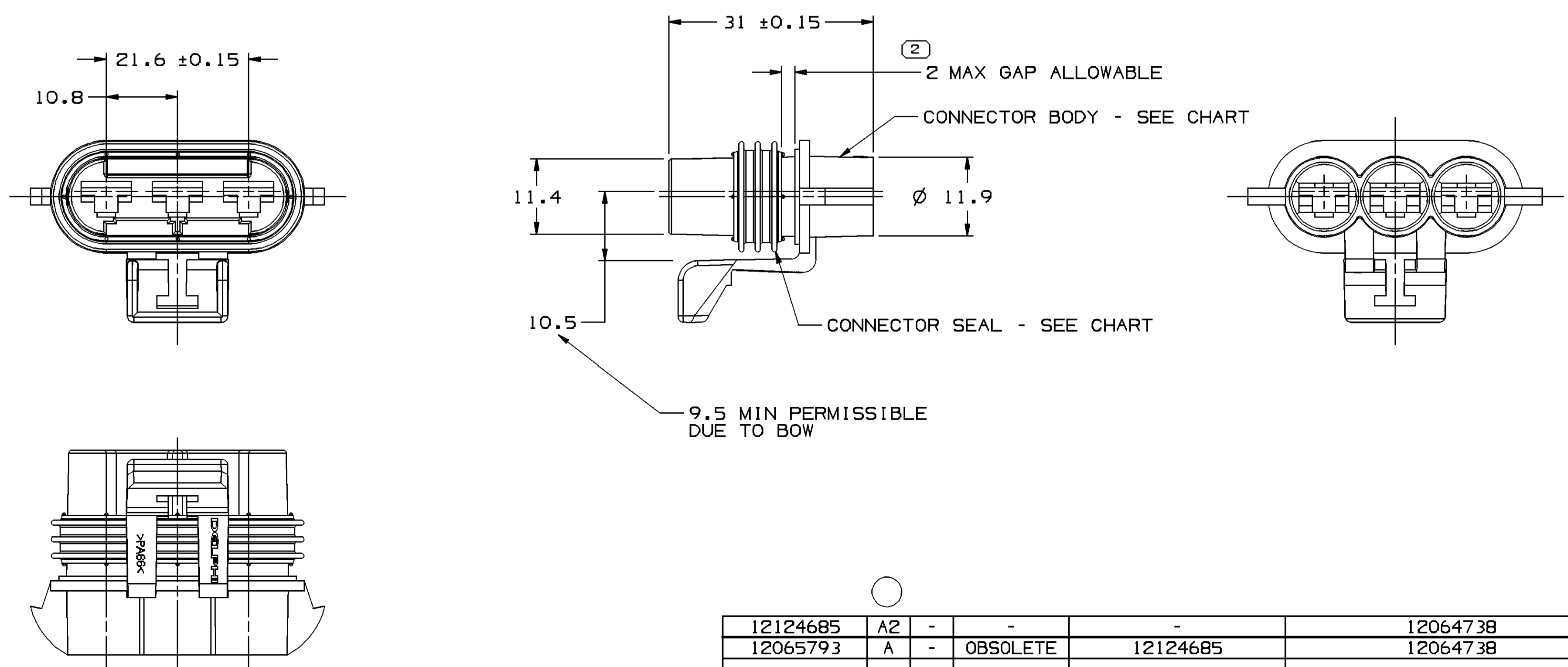
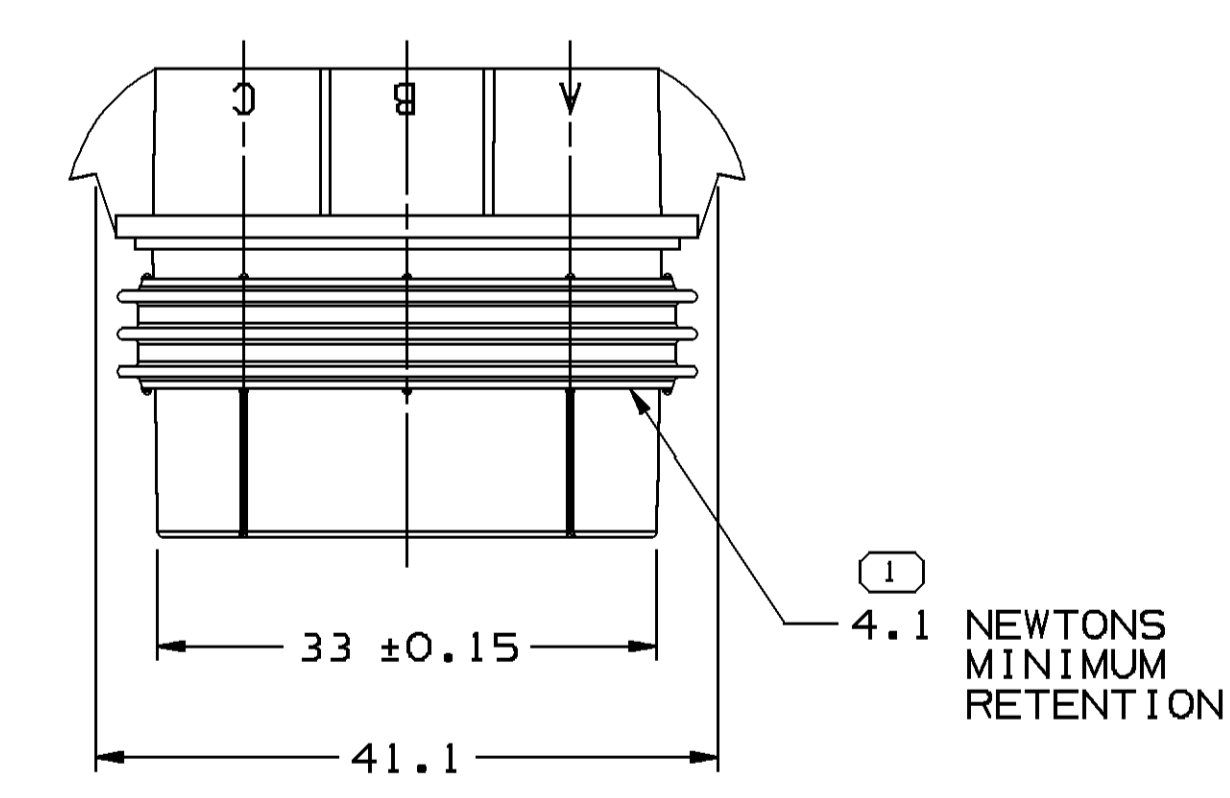

PART NO	REV	N/P	STATUS	REPLACED BY	CONNECTOR BODY	CONNECTOR SEAL
12124685	A2	-	-	-	12064738	12124684 BRIGHT RED
12065793	A	-	OBSOLETE	12124685	12064738	12045698 GREEN

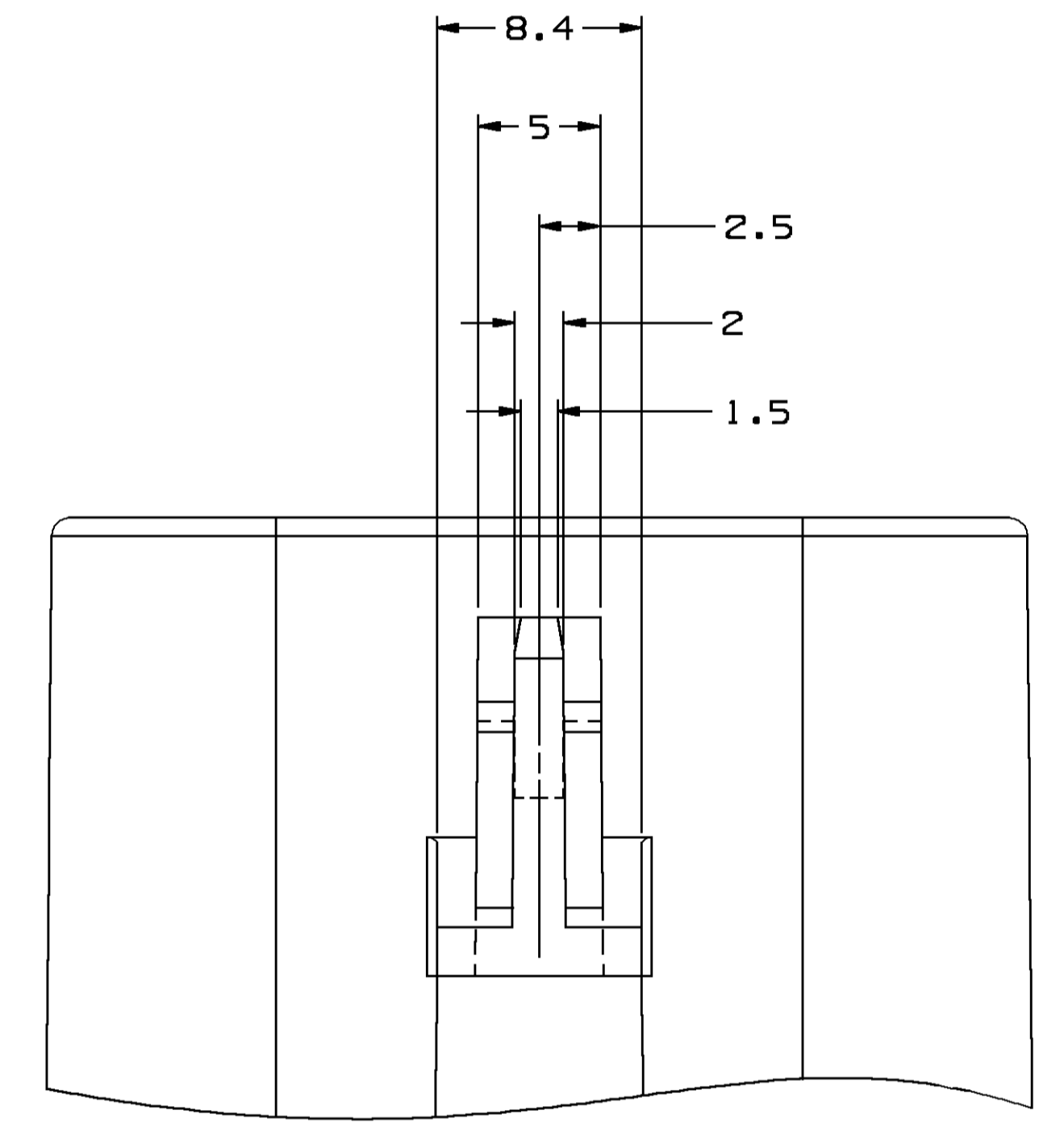
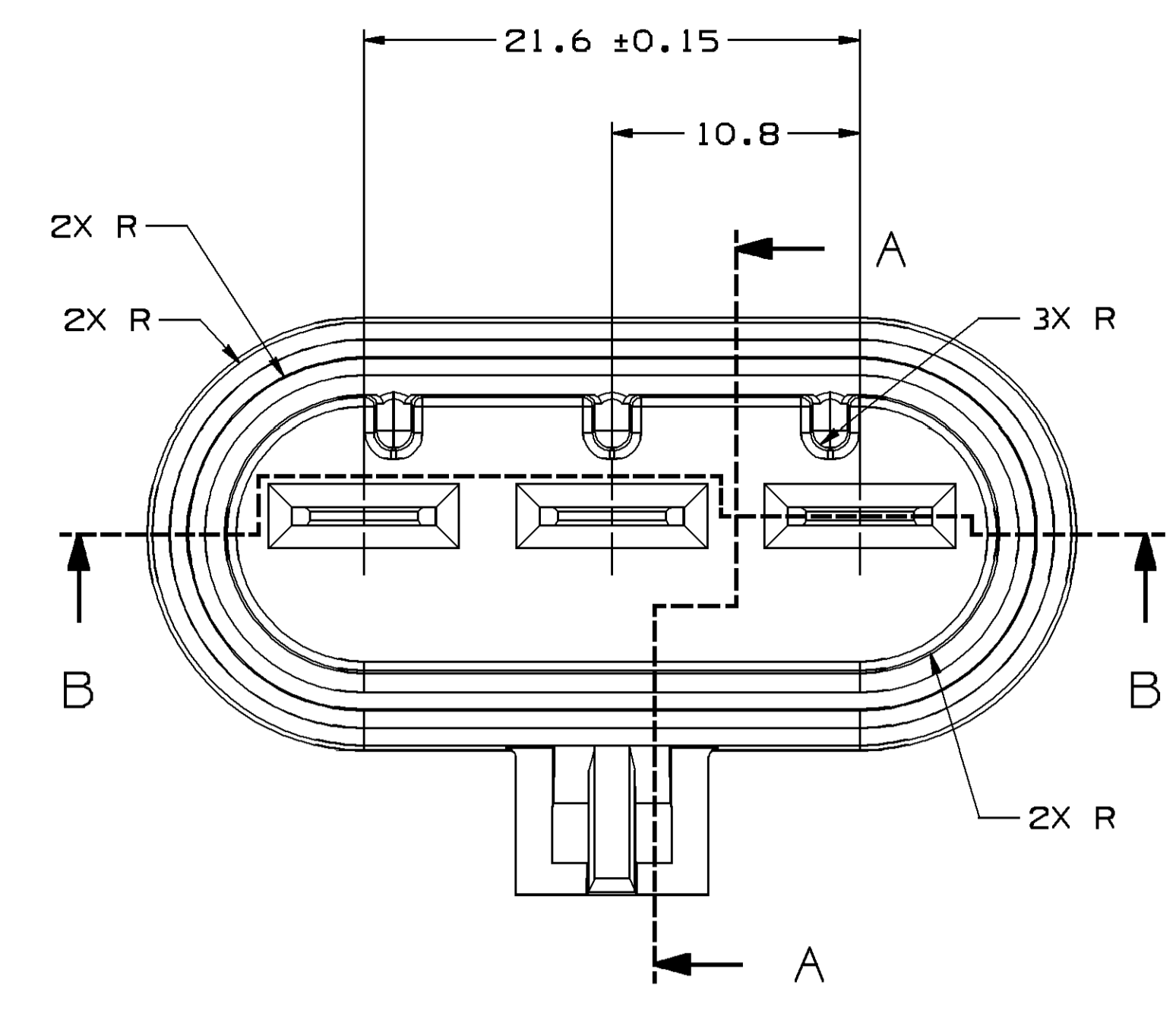

- NOTES**
- UNLESS OTHERWISE SPECIFIED AND/OR INDICATED:  
 DIMENSIONS ARE TO FACE OF VIEW SHOWN AND AUTOMATICALLY ROUNDED BY COMPUTER FOR INSPECTION (SEE MATH MODEL FOR PRECISE DIMENSIONS). FOR ALL OTHER DIMENSIONS NOT SHOWN BUT REQUIRED FOR TOOL BUILD, SEE MATH MODEL FOR PRECISE TOOL PATH DATA. ALL RADII 0.4  
 DRAFT IS 1° MAX ON ALL OUTSIDE SURFACES.
  - RECOMMENDED MATERIAL - GLASS FILLED NYLON OR POLYESTER.
  - WHEN USING THIS INFORMATION FOR A NEW DESIGN, REQUEST THE LATEST COPY OF THIS PRINT FROM PACKARD ELECTRIC DIVISION.

SYMBOL DEFINITION		TOTAL NO OF INSPECTIONS REQUIRED	MISSING SYMBOLS
A	DIMENSION WITHOUT AN INSPECTION REPORT SYMBOL DOES NOT REQUIRE INSPECTION. IT MAY BE CONTROLLED ON THE INDIVIDUAL COMPONENT DRAWING.	2	NO MISSING SYMBOL NUMBER
		LAST NO. USED	2

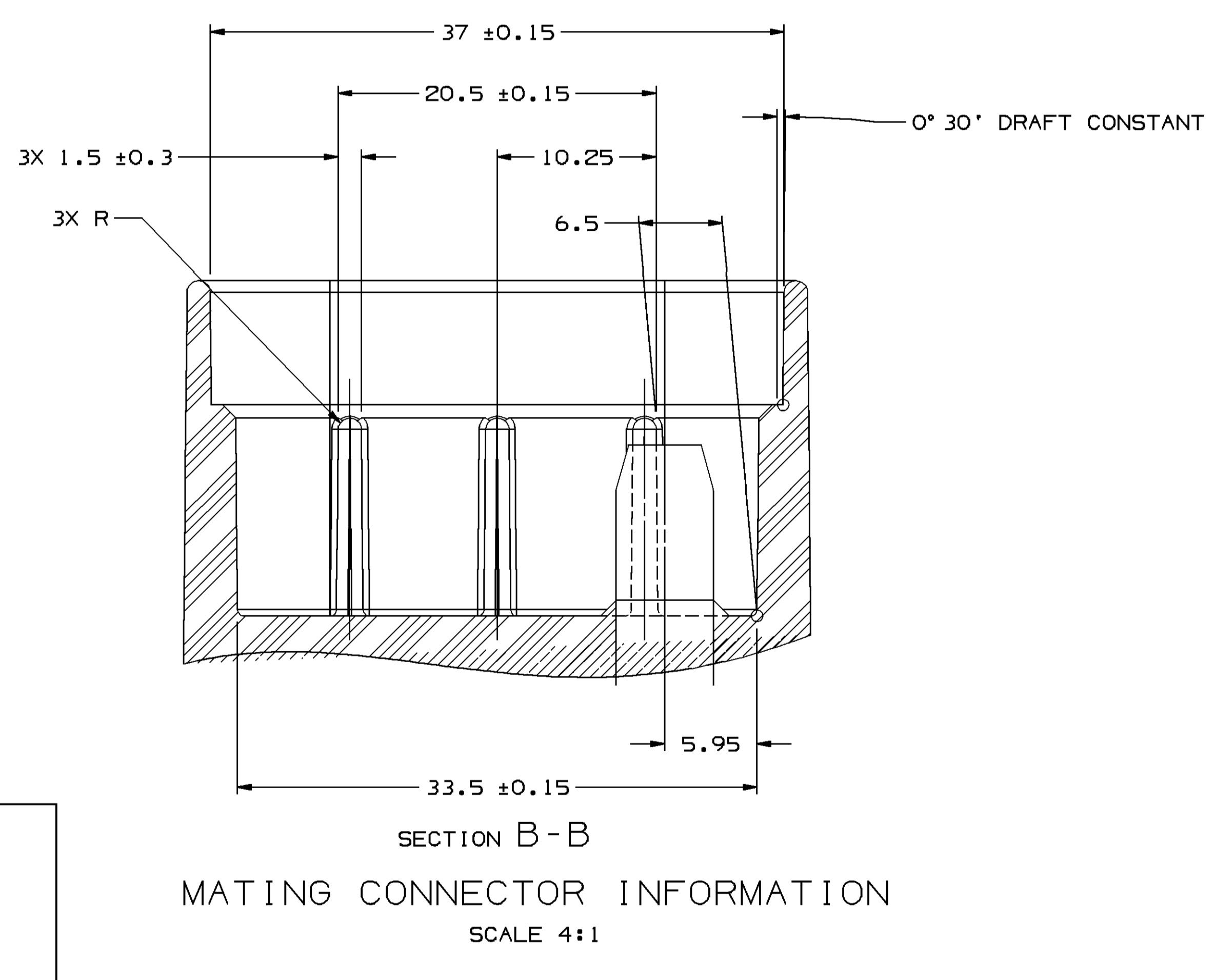
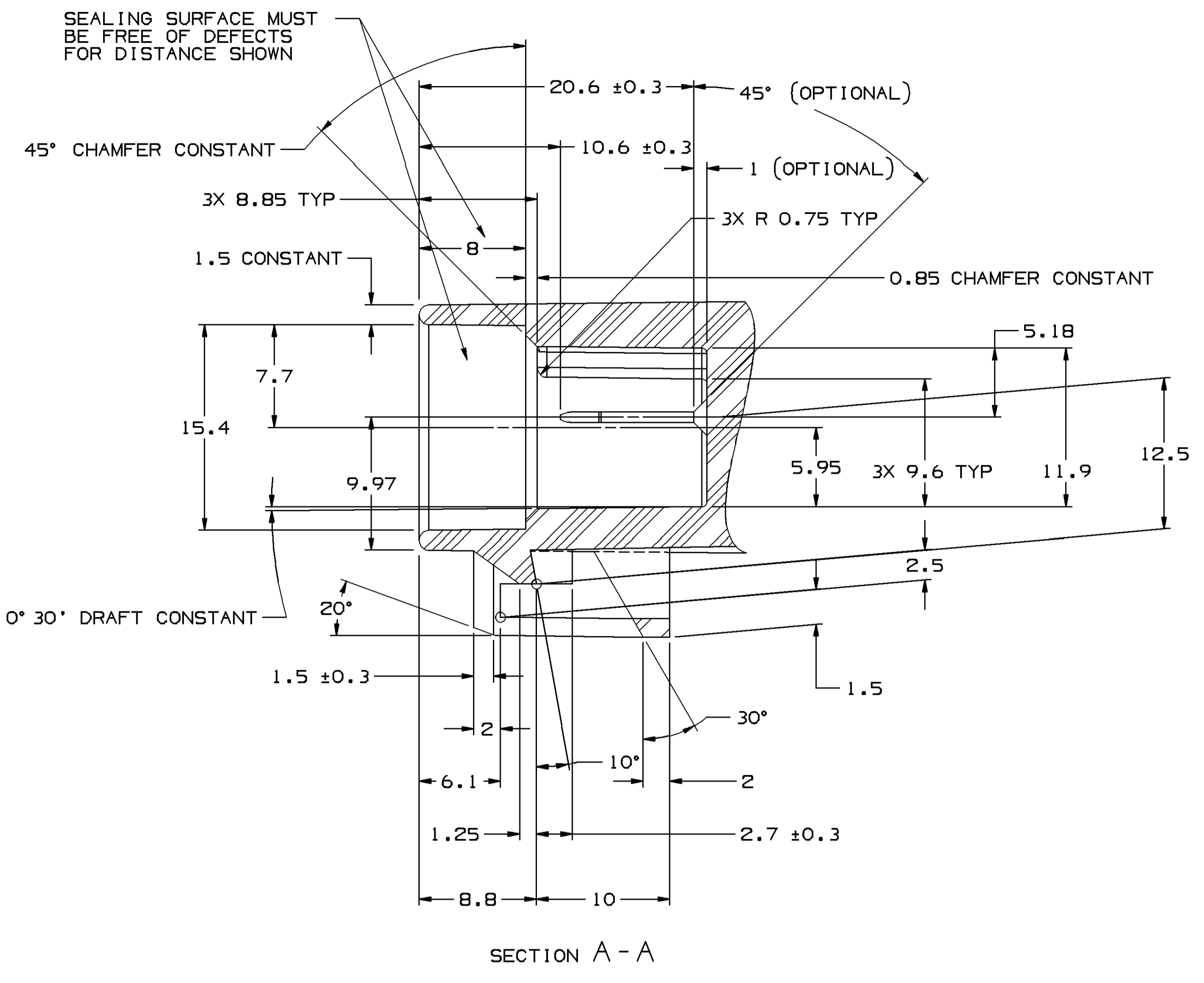

- NOTES**
- UNLESS OTHERWISE SPECIFIED AND/OR INDICATED:  
 DIMENSIONS ARE TO FACE OF VIEW SHOWN AND AUTOMATICALLY ROUNDED BY COMPUTER FOR INSPECTION (SEE MATH MODEL FOR PRECISE DIMENSIONS). FOR ALL OTHER DIMENSIONS NOT SHOWN BUT REQUIRED FOR TOOL BUILD, SEE MATH MODEL FOR PRECISE TOOL PATH DATA.
  - WHEN PARTS ARE SHIPPED, THEY MUST BE PACKED IN PLASTIC BAGS OR SHIPPING CONTAINERS THAT MUST BE LINED WITH PLASTIC LINERS. BAGS OR LINERS MUST BE SEALED TO AVOID FOREIGN MATTER.
  - DESIGN WILL PASS SALT FOG AND IMMERSION TEST AFTER CONDITIONING AS SPECIFIED IN ESA-710 (METRI-PACK), WHEN MATED TO MATING PART OR EQUIVALENT.
  - THIS PART IS NOT CONTROLLED FOR AUTOMATIC FEEDING.
  - SEE CABLE SEAL AND SECONDARY TERMINAL LOCK DRAWINGS FOR COMPATIBLE CABLE O.D. RANGE.
  - FOR APPLICATION DATA SEE THE INDIVIDUAL APPLICATION DRAWINGS.
  - THIS PRODUCT IS NOT CATEGORIZED AS AN APPEARANCE ITEM, MINOR IMPERFECTIONS INCLUDING, BUT NOT LIMITED TO, FLOW MARKS, COLOR BLEMISHES, GATE VESTIGE, AND SOFT FLASH THAT DO NOT AFFECT THE FIT, FORM, OR FUNCTION OF THE PART ARE PERMISSIBLE PER NAP 4.10-18.

DIMENSIONAL RANGE (MM)	TOLERANCE UNLESS OTHERWISE SPECIFIED	ANGLE TOLERANCE
FROM > 0 TO > 20	±0.15	±1
> 20 TO > 30	±0.2	±1
> 30 TO > 70	±0.3	±1
> 70 TO > 100	±0.4	±1
> 100 TO > 150	±0.5	±1
> 150 TO > 200	±0.6	±1
> 200 TO > 300	±0.8	±1
> 300 TO > 400	±1.0	±1

DATE	STG	REV	N/P	CHG	ZONE	REVISION HISTORY	AUTH	DR	AP/VD	AP/VD
17FE93	R	-	-	-	-	12045793 - WAS SEPARATE "D" SIZE REVISED; REV LEVEL REMAINS AT "A"	152084	CP		
17FE93	R	-	-	-	-	12124685 - RELEASED TO REV "A"	930005	CP		
02AU94	R	-	-	-	-	12065793 - OBSOLETE	940003	TW	TW	
18OC06	R	01	-	-	-	ALL ACTIVE PARTS - REDRAWN TO PD	285577	RMG	AMG	BDG
21JA08	R	02	-	-	-	ALL ACTIVE PARTS - AD CREATED, ADDED SHEET 1 OF 2	403544	MSM	DGL	MSM

**DELPHI**  
 DELPHI PACKARD ELECTRICAL/ELECTRONIC ARCHITECTURE  
 WARREN, OH

DR	DATE
AP/VD1 CHUCK PAPAS	17FE93
AP/VD2 CHUCK PAPAS	17FE93
AP/VD3 BRIAN GROUBERT	230C06
AP/VD4	
AP/VD5	

SUBSTANCES OF CONCERN AND RECYCLED CONTENT PER DELPHI 10949001

DRAWING NAME  
 TAXI ASM CONN F M/P 630 SLD

DRAWING NUMBER  
**12124687**

SCALE: 2:1  
 SHEET NO: 1 OF 1  
 SHEET REV: 1 OF 2  
 REV N/P: R 02