

## GN three phase - Three phase solid state relay - GN3 serie

---

### Selling points of the range

- + Ratings up to 50 amps per phase at 600 V AC
- + Epoxy-free design minimizes internal component stress
- + 100 k-cycle UL508 Endurance rating for enhanced reliability
- + No external transient protection required (Internal TVS)
- + Back-to-back SCR output for heavy industrial loads
- + Available with zero-crossing (resistive loads) or random-fire (inductive loads) outputs
- + UL, CSA, TUV Approved, CE compliant
- + EMC compliant for reliable operation in harsh environments
- + RoHS compliant



Part number characteristics	GN325ESZ
Current (A)	25
Input voltage (V)	18-36 V AC
Output voltage (V)	48-530 V AC
RC network	Yes
Switching	Zero

## **GN325ESZ : GN three phase - Three phase solid state relay - GN3 serie**

<b>General characteristics</b>		
Operating temperature (°C)	-40 → +80	
Storage temperature (°C)	-40 → +100	
Input-to-Output isolation voltage (Vrms)	4000	
Input/Output to ground isolation voltage (Vrms)	2500	
Operating frequency (Hz)	47-63	
Housing material	Polycarbonate UL-94V0	
Heatsink material	Copper	
Protection (IEC 60529) - Casing	IP20	
Weight (g)	360	
Altitude for nominal performance (/sea level)	2000 m	
Input terminal capacity (stranded and solid wire)	14-24 AWG	
Input terminal tightening torque (Nm)	1.9	
Min. output terminal capacity (IEC 941-1)	16 AWG	
Max. output terminal capacity (IEC 941-1) stranded wire	8 AWG	
Max. output terminal capacity (IEC 941-1) solid wire	8 AWG	
Output terminal tightening torque (Nm)	2.4	
Maximum cross section for output wire (mm <sup>2</sup> )	8.5	
<b>Safety standards</b>		
Conformity to standards	IEC 62314 IEC 60947-4-2 (AC 53a) IEC 60947-4-3 (AC 51) CE compliant with LVD 73/23/EEC TUV certified per EN 60950-1 CSA recognized per C22.2.no.14-95 UL/cUL recognized per UL 508	
Vibrations according to IEC/EN60068-2-6	35 mm / 10-55 Hz	
Shock test IEC 60068-2-27	15 G / 11 ms	
Immunity to electrostatic discharges acc. IEC/EN 61000-4-2	Level 3	
Immunity to electrostatic fields acc. ENV 50140/204 (IEC 1000-4-3)	Level 3	
Immunity to rapid transient bursts acc. to IEC 1000-4-4	Level 3	
Immunity to shock waves according to IEC/EN 61000-4-5	Level 3 for Ac input part numbers Level 0 for DC input part numbers	
Immunity to radio frequency in common mode acc. to ENV (CEI 1000-4-6)	Level 3	
Conducted and radiated noise for industrial environments per CISPR 11	Class 3	
<b>Relay output characteristics</b>		
Current (A)	25	50
Voltage range (Vrms max)	48-600	48-600
Non-rep. peak voltage (Vpeak)	1100	1100
Maximum off-state leakage at Vmax and T = 25 °C (mAeff per phase)	0.06-3 (Without / With RC network)	0.06-3 (Without / With RC network)
Current max @ 40°C (A)	25	50
Minimum current (mArms)	100	100
On-state voltage drop at I max (Vpeak)	1.35 (40°C ambient)	1.35 (40°C ambient)
I <sup>2</sup> t (t = 10 ms) (A <sup>2</sup> s) (50 - 60 Hz)	1250-1040	3200-2600

Static (off-state) dv/dt (V/ $\mu$ s)	500	500		
HP ratings at 120 V	0.75	1.5		
HP ratings at 240 V	1	3		
HP ratings at 480 V	3	7.5		
HP ratings at 600 V	5	10		
Utilization category AC 51 (A)	25	50		
Utilization Category AC-53 (A)	5	10		
Max. non-rep. 1 s surge (T=25°C) (A)	100	160		
Max. non-rep. 1-cycle surge (T=25°C) (A)	500	800		
Thermal resistance junction to casing ( $^{\circ}$ C/W)	0.24	0.12		
<b>Inputs specifications</b>				
Input voltage (V)	4-32 V DC	18-36 V AC	90-140 V AC	180-260 V AC
Turn-off voltage (V)	1	2	10	10
Max. controlled current (mA)	35	20	16	9
Min. input current (mA)	24	15	10	20
Turn-on time (ms) (zero voltage relay)	8.33 (60Hz) - 10 (50Hz)	28	7	28
Turn-on-time (ms) (instantaneous relay)	0.1	20	20	20
Max. turn-off time (ms)	8.33 (60Hz) - 10 (50Hz)	30	30	30

**GN325ESZ : GN three phase - Three phase solid state relay - GN3 serie**

GN3

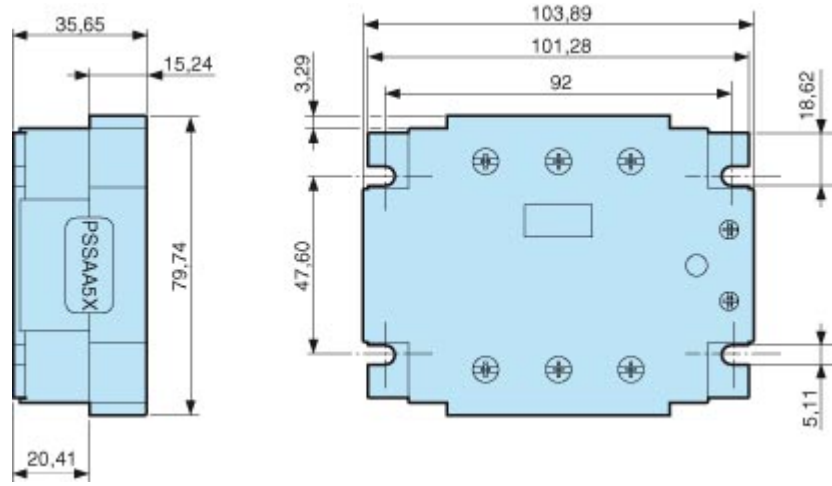

 Zoom

**GN325ESZ : GN three phase - Three phase solid state relay - GN3 serie  
GN3 25 Amp.**

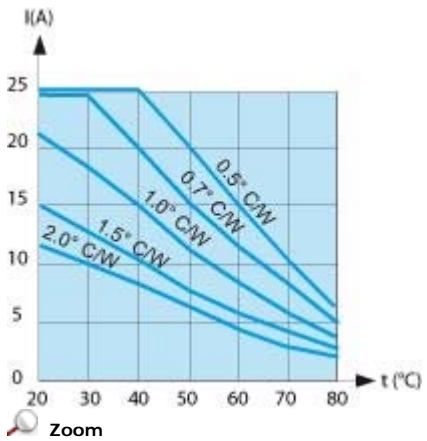

**GN3 50 Amp.**

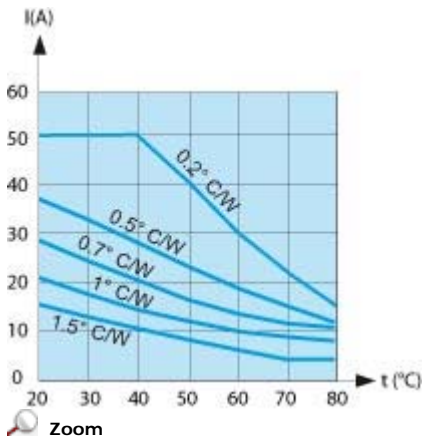

GN325ESZ : GN three phase - Three phase solid state relay - GN3 serie

Equivalent AC input circuit without RC network

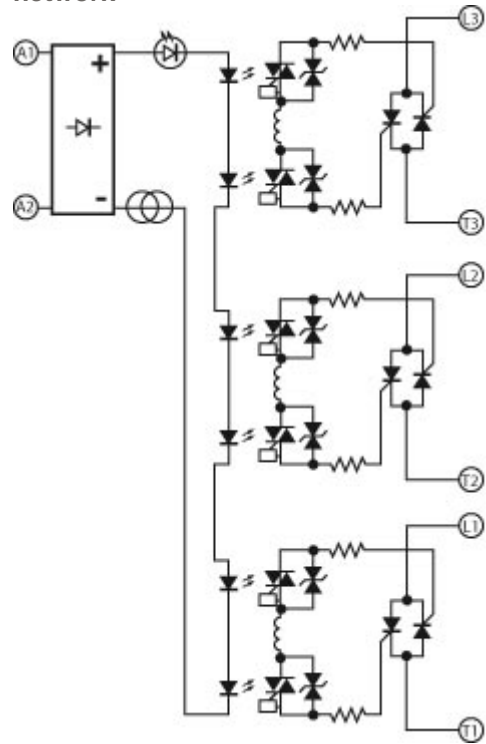

Zoom

Equivalent AC input circuit with RC network

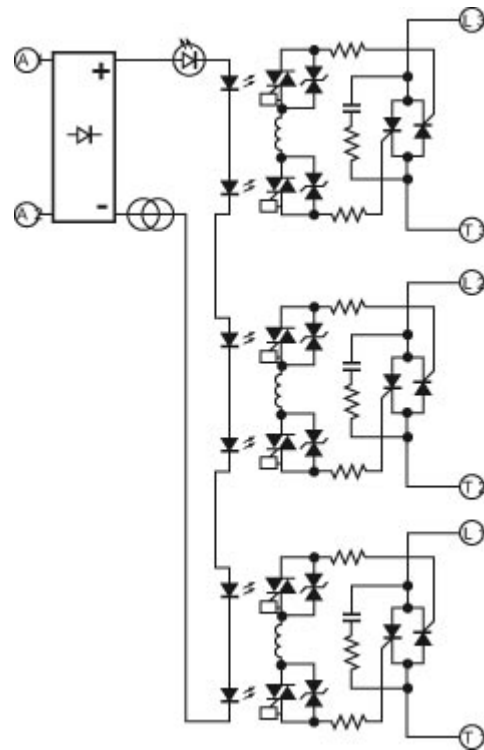

Equivalent DC input circuit without RC network

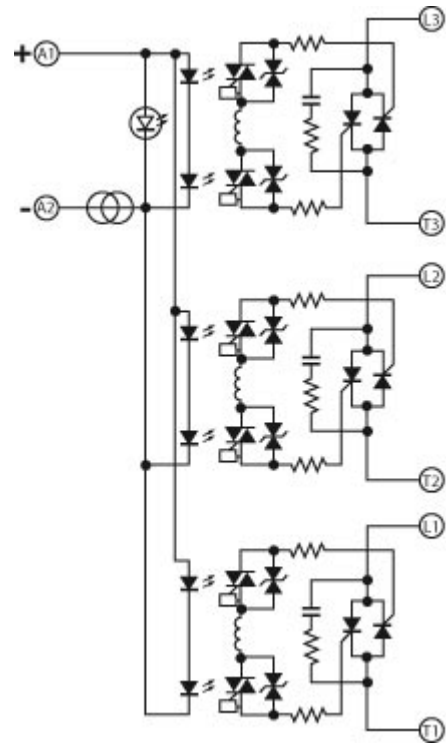

Equivalent DC input circuit with RC network

