

CROSSED ROLLER BEARINGS

- High Rigidity Type Crossed Roller Bearings (V)
- Standard Type Crossed Roller Bearings
- Super Slim Type Crossed Roller Bearings
- Slim Type Crossed Roller Bearings
- Mounting Holed Type High Rigidity Crossed Roller Bearings (V)



Structure and Features

IKO Crossed Roller Bearings are compact bearings with their rollers alternately crossed at right angles to each other between inner and outer rings. They can take loads from any directions at the same time such as radial, thrust and moment loads. The rollers make line-contact with raceway surfaces, and, therefore, elastic deformation due to bearing loads is very small. These bearings are widely used in the rotating parts of industrial robots, machine tools, medical equipment, etc., which require compactness, high rigidity and high rotational accuracy. In addition, bearings made of stainless steel or those with inner and outer rings provided with mounting holes are also available on request. Please contact **IKO**.

Structure of Crossed Roller Bearings

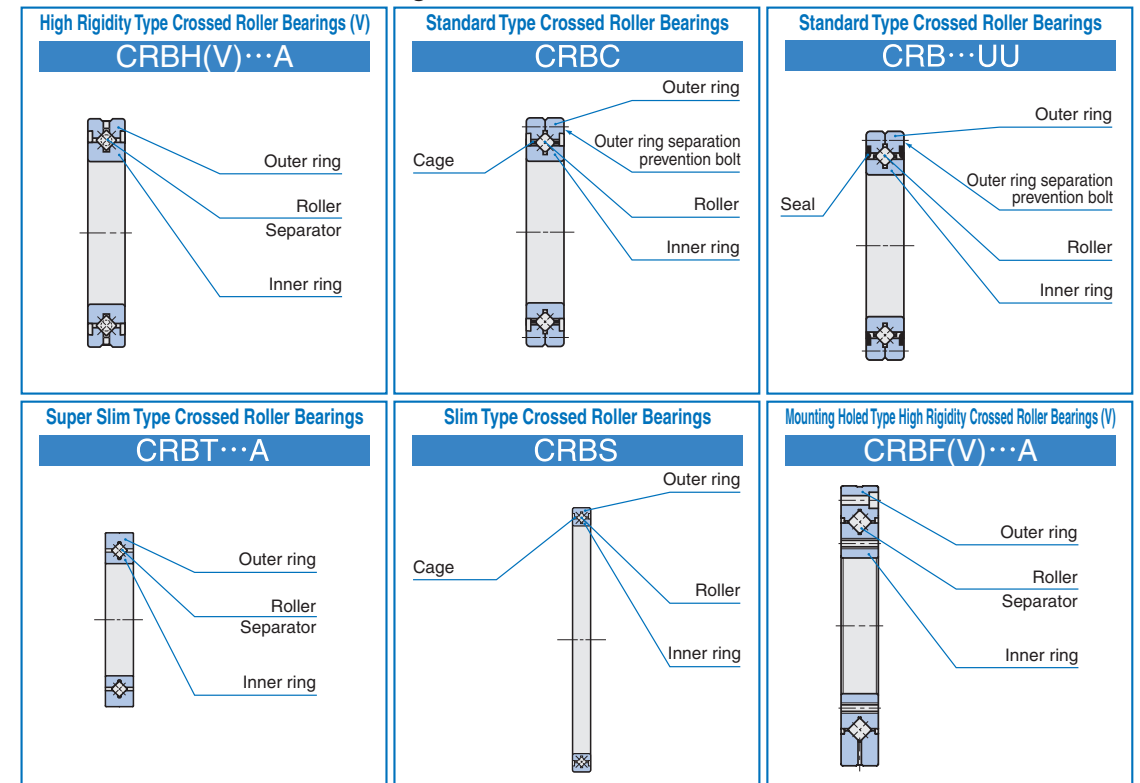

J
CRBH
CRBC
CRB
CRBT
CRBS
CRBF

Crossed Roller Bearings are available in the types shown in Table 1.

Table 1 Crossed Roller Bearing Type

Type		With Cage	With Separator	Full complement
High Rigidity Type Crossed Roller Bearings (V) CRBH(V)	Open type	—	CRBH(V) ··· A	—
	Sealed type	—	CRBH(V) ··· AUU	—
Standard Type Crossed Roller Bearings CRBC, CRB	Open type	CRBC	—	CRB
	Sealed type	CRBC ··· UU	—	CRB ··· UU
Super Slim Type Crossed Roller Bearings CRBT	Open type	—	CRBT ··· A	—
Slim Type Crossed Roller Bearings CRBS	Open type	CRBS	—	CRBS ··· V
	Sealed type	—	CRBS ··· AUU	CRBS ··· VUU
Mounting Holed Type High Rigidity Crossed Roller Bearings (V) CRBF(V)	Open type	—	CRBF(V) ··· A	—
	Sealed type	—	CRBF(V) ··· AUU	—

High Rigidity Type Crossed Roller Bearings

Both inner and outer rings have a solid one-piece construction. Therefore, high accuracy and high rigidity are achieved, and mounting errors can be minimized. As separators are incorporated between the cylindrical rollers for smooth rotation, these bearings are suitable for applications where rotational speed is comparatively high.

Standard Type Crossed Roller Bearings

The outer ring is made of two split pieces, which are bolted together to prevent separation during transportation or mounting. So, handling is easy.

Super Slim Type Crossed Roller Bearings

This Type is extremely compact bearing having 5.5mm of sectional height and 5mm of width. Separators are incorporated between Cylindrical rollers for smooth rotation. These compactness, lightness and smoothness contribute downsizing of the machine and saving driving power.

Slim Type Crossed Roller Bearings

These bearings are slim bearings having a small outside diameter, in comparison with the bore diameter, and a narrow width. The type with cage and the type with separator provide smooth rotation and are suitable for applications where rotational speed is comparatively high.

Mounting Holed Type High Rigidity Crossed Roller Bearings

Mounting holes are prepared on outer ring and inner ring providing easy mounting together with high rigidity and high accuracy.

High Rigidity Type Crossed Roller Bearings V Mounting Holed Type High Rigidity Crossed Roller Bearings V

While the basic performance is on a level with that of High Rigidity Crossed Roller Bearings and Mounting Holed Type High Rigidity Crossed Roller Bearings, the establishment of a dedicated production site and the revision of design and manufacturing processes have enabled cost reductions and shortened lead times. This product contributes to machinery/equipment cost reductions and shorter delivery times.

Features of Super Slim Type Crossed Roller Bearing CRBT

The world's thinnest roller type! Very low cross sectional height of 5.5 mm

The cross sectional height is reduced by 69% in comparison with CRBS, which was the thinnest before (bearing bore diameter 50 mm). The width is also as small as 5 mm and the cross sectional area is reduced by 43% in comparison with conventional products.

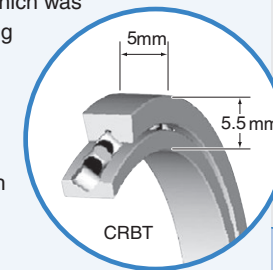

Comparison of bearing bore diameter 50 mm

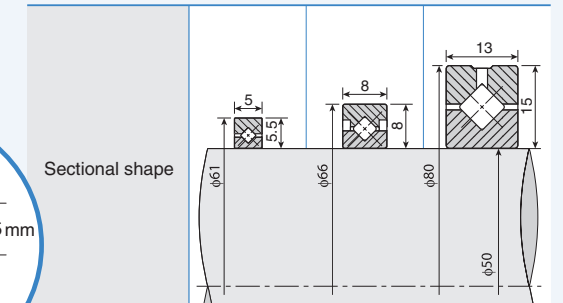

Series	Super Slim CRBT505A	Slim CRBS508	High rigidity CRBH5013A
Item			
Outer diameter mm	61	66	80
Width mm	5	8	13
Sectional height mm	5.5	8	15
C	N	2280	4900
C ₀	N	3200	6170
Mass g	32.3	84	290
	Compared with CRBH	0.11	0.29
	Compared with CRBS	0.38	1.00

Significant weight saving by 38% in comparison with conventional types was realized

Weight reduction is thoroughly pursued. The mass ratio is 0.38 and significant weight saving was realized in comparison with conventional slim type CRBS (bearing bore diameter 50 mm).

Features of Mounting Holed Type High Rigidity Crossed Roller Bearing (V) CRBF(V)

High rigidity and high accuracy

The single structure to reduce the mounting errors is adopted for both inner and outer rings. Further, mounting holes for direct fixing on mating mounting surface are available. So high rigidity and high accuracy guide can be easily realized, being less subject to the structure of the housing and the accuracy.

Contributing to miniaturization

It can be easily mounted to a device with bolts without need for housing and fixing plate, so surrounding parts of the bearing can be made compact. Further, it allows for reduction of the number of parts and assembly processes, which contributes to miniaturization and weight saving of devices.

Complex mounting structure is not required
Easy bolt-on installation

With mounting holes

No division for both inner and outer rings and high rigidity single structure

Single structure for both inner and outer rings!
Mounting Holed Type High Rigidity Crossed Roller Bearing (V)
CRBF(V)

Internal Structures and Shapes

Various types are lined up in Crossed Roller Bearing series, including the type with cage, the type with separator, open type, sealed type, etc..

Roller guide method

Crossed Roller Bearings include the type with cage, type with separator and full complement type. The type with cage and the type with separator have a small coefficient of friction and are suitable for com-

paratively high speed rotations, while the full complement type is suitable for heavy load applications at low speed rotations.

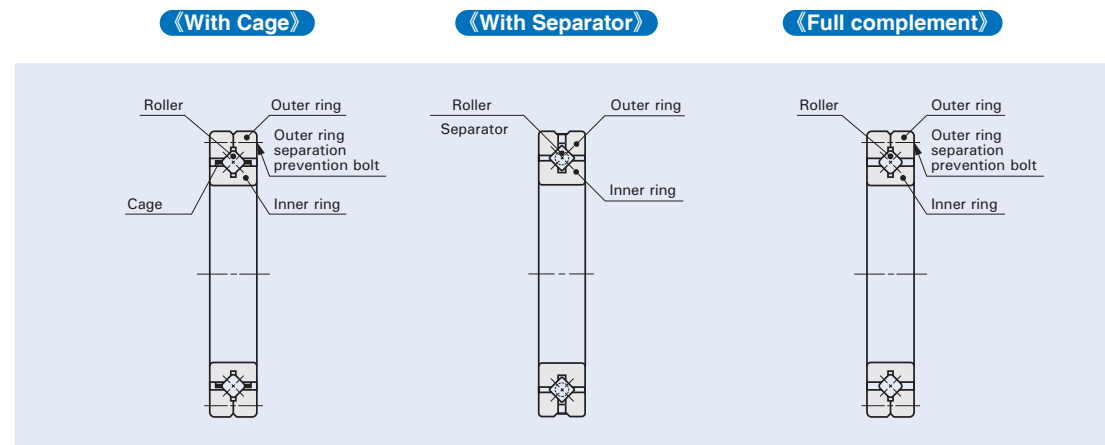

Seal structure

Crossed Roller Bearings include the open type and sealed type. The sealed type bearing incorporates seals made of special synthetic rubber that have

excellent sealing performance against dust and dirt penetration and grease leakage. However, excess grease may be discharged during initial operations.

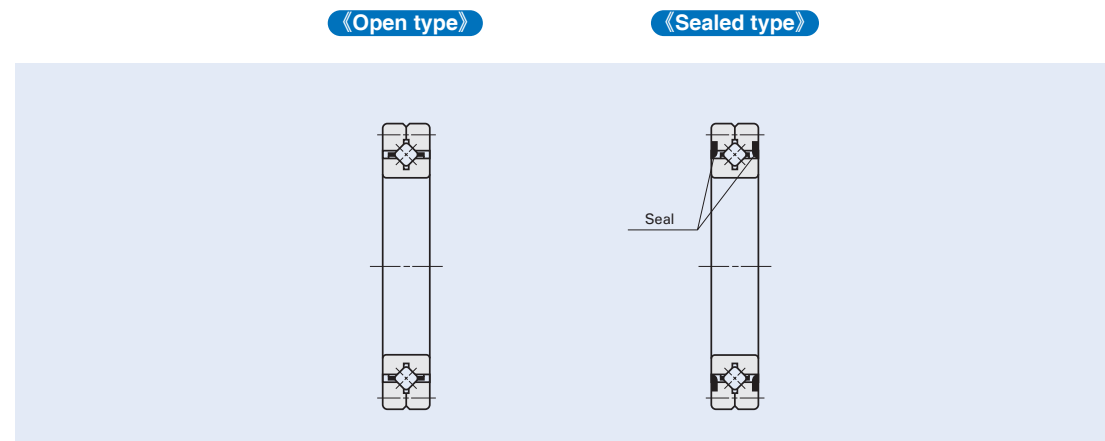

Identification number

The identification number of Crossed Roller Bearings consists of a model code, dimensions, any supplemental codes and a classification symbol. Some examples are shown below.

Examples of identification number

	Model code	Dimensions	Supplemental code	Classification symbol
Example 1	CRBHV	150 25 A	UU C1	P6
Example 2	CRBC	150 25	UU C1	P6
Example 3	CRBT	30 5 A	C1	
Example 4	CRBS	150 8 A	UU C1	
Example 5	CRBFV	115 28 A	D UU C1	RP6

Model code	
CRBH(V)···A	High Rigidity Type Crossed Roller Bearing (V) (With separator)
CRBC	Standard Type Crossed Roller Bearing (With cage)
CRB	Standard Type Crossed Roller Bearing (Full complement)
CRBT···A	Super Slim Type Crossed Roller Bearing (With separator)
CRBS	Slim Type Crossed Roller Bearing (With cage)
CRBS···A	Slim Type Crossed Roller Bearing (With separator)
CRBS···V	Slim Type Crossed Roller Bearing (Full complement)
CRBF(V)···A	Mounting Holed Type High Rigidity Crossed Roller Bearing (V) (With separator)

Dimension	
The dimension indicates the bore diameter of the bearing. (unit : mm)	
The dimension indicates the bearing width. (unit : mm)	

Supplemental code - 1 ⁽¹⁾	
T	With female threaded mounting holes on the inner ring
No symbol	With counter-bored mounting holes on both inner ring and outer ring in the same direction.
D	With counter-bored mounting holes on both inner ring and outer ring in the opposite direction.

Note⁽¹⁾ Applicable to Mounting Holed Type High Rigidity Crossed Roller Bearing (V).

Supplemental code - 2	
No symbol	Open type
UU	Sealed type
U	One side sealed type ⁽²⁾
UD	One side sealed in the opposite direction to counter bored mounting holes on outer ring

For application, please see table 2.

Note⁽²⁾ For CRBF···A, sealed at the side with counter bored mounting holes of outer ring.

Supplemental code - 3	
T1	: T1 clearance
C1	: C1 clearance
C2	: C2 clearance
No symbol	: Normal clearance

For application, please see table 3.

Classification symbol	
No symbol	Accuracy class 0
P6	Accuracy class 6
P5	Accuracy class 5
P4	Accuracy class 4
P2	Accuracy class 2
RP6	Rotational accuracy class 6
RP5	Rotational accuracy class 5
RP4	Rotational accuracy class 4
RP2	Rotational accuracy class 2

For application, please see table 4.

Rotational accuracy class---classes specifying accuracy standards for only rotational accuracy (radial runout, axial runout).

J
CRBH
CRBC
CRB
CRBT
CRBS
CRBF

Table 2 Seal Specification

Model code	No Symbol	UU	U	UD
CRBH ... A	○	○	○	—
CRBHV ... A	○	○	—	—
CRBC	○	○	○	—
CRB	○	○	○	—
CRBT ... A	○	—	—	—
CRBS	○	—	—	—
CRBS ... A	—	○	○	—
CRBS ... V	○	○	○	—
CRBF ... A	○	○	○	○
CRBFV ... A	○	○	—	—

Table 3 Clearance Specification

Model code	T1	C1	C2	No Symbol
CRBH(V) ... A	○	○	○	—
CRBC	○	○	○	—
CRB	○	○	○	—
CRBT ... A	—	○	—	—
CRBS	○	○	—	○
CRBS ... A	○	○	—	○
CRBS ... V	○	○	—	○
CRBF(V) ... A	○	○	○	—

Table 4 Accuracy Class

Model code	No Symbol	P6 RP6	P5 RP5	P4 RP4	P2 RP2
CRBH(V) ... A	○	○	○	○	○
CRBC	○	○	○	○	○
CRB	○	○	○	○	○
CRBT ... A	○	—	—	—	—
CRBS	○	—	—	—	—
CRBS ... A	○	—	—	—	—
CRBS ... V	○	—	—	—	—
CRBF(V) ... A	○	○	○	○	○

Dynamic Equivalent Load

The direction of basic dynamic load rating of Crossed Roller Bearing is the radial direction. When a load in any direction other than the direction of basic dynamic load rating or a complex load is applied, calculate the dynamic equivalent load to calculate the rating life.

$$P_r = X \left(F_r + \frac{2M}{D_{pw}} \right) + Y F_a \dots\dots\dots(1)$$

where, P_r : Dynamic equivalent radial load, N
 F_r : Radial load, N
 F_a : Axial load, N
 M : Moment, N-mm
 D_{pw} : Pitch circle diameter of roller set, mm

$$\left(D_{pw} \doteq \frac{d + D}{2} \right)$$

X : Radial load factor (Refer to Table 5.)

Y : Axial load factor (Refer to Table 5.)

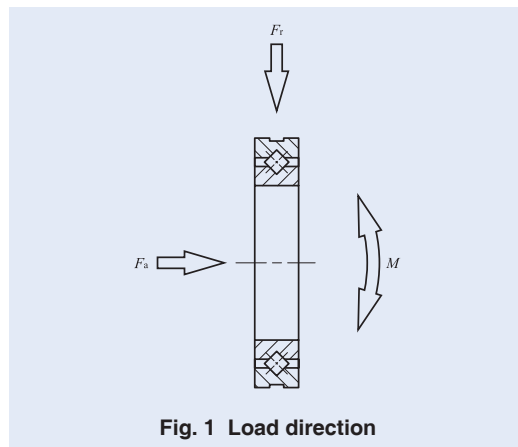

Fig. 1 Load direction

Table 5 Radial load factor and axial load factor

Conditions	X	Y
$\frac{F_a}{F_r + 2M/D_{pw}} \leq 1.5$	1	0.45
$\frac{F_a}{F_r + 2M/D_{pw}} > 1.5$	0.67	0.67

Static Equivalent Load

The direction of basic static load rating of Crossed Roller Bearing is the radial direction. When a load in any direction other than the direction of basic static load rating or a complex load is applied, calculate the static equivalent load to calculate the static safety factor.

$$P_{0r} = F_r + \frac{2M}{D_{pw}} + 0.44 F_a \dots\dots\dots(2)$$

where, P_{0r} : Static equivalent radial load, N
 F_r : Radial load, N
 F_a : Axial load, N
 M : Moment, N-mm
 D_{pw} : Pitch circle diameter of roller set, mm

$$\left(D_{pw} \doteq \frac{d + D}{2} \right)$$

Accuracy

The accuracy of Crossed Roller Bearings, Super Slim Type Crossed Roller Bearings, Slim Type Crossed Roller Bearings and Mounting Holed Type High

Rigidity Crossed Roller Bearings is shown below in Table 6 - 10.2.

Bearings with special accuracy are also options. Please consult IKO .

Table 6 Tolerances and allowable values of inner rings and tolerances of outer ring width

unit: μ m

Nominal bore diameter mm	$\Delta_{dmp}^{(1)}$ Single plane mean bore dia. deviation										Δ_{Bs} Deviation of a single inner ring width		$\Delta_{Cs}^{(2)}$ Deviation of a single outer ring width		K_{ia} Radial run-out of assembled bearing inner ring					S_{ia} Assembled bearing inner ring face run-out with raceway				
	Class 0 RP6-2		P6		P5		P4		High	Low	High	Low	Class 0	P6	P5	P4	P2	Class 0	P6	P5	P4	P2		
	Over	Incl.	High	Low	High	Low	High	Low															High	Low
18	30	0	-10	0	-8	0	-6	0	-5	0	-75	0	-100	13	8	4	3	2.5	13	8	4	3	2.5	
30	50	0	-12	0	-10	0	-8	0	-6	0	-75	0	-100	15	10	5	4	2.5	15	10	5	4	2.5	
50	80	0	-15	0	-12	0	-9	0	-7	0	-75	0	-100	20	10	5	4	2.5	20	10	5	4	2.5	
80	120	0	-20	0	-15	0	-10	0	-8	0	-75	0	-100	25	13	6	5	2.5	25	13	6	5	2.5	
120	150	0	-25	0	-18	0	-13	0	-10	0	-100	0	-120	30	18	8	6	2.5	30	18	8	6	2.5	
150	180	0	-25	0	-18	0	-13	0	-10	0	-100	0	-120	30	18	8	6	5	30	18	8	6	5	
180	250	0	-30	0	-22	0	-15	0	-12	0	-100	0	-120	40	20	10	8	5	40	20	10	8	5	
250	315	0	-35	0	-25	0	-18	—	—	0	-120	0	-150	50	25	13	10	7	50	25	13	10	7	
315	400	0	-40	0	-30	0	-23	—	—	0	-150	0	-200	60	30	15	12	8	60	30	15	12	8	
400	500	0	-45	0	-35	—	—	—	—	0	-150	0	-200	65	35	18	14	10	65	35	18	14	10	
500	630	0	-50	0	-40	—	—	—	—	0	-150	0	-200	70	40	20	16	12	70	40	20	16	12	
630	800	0	-75	—	—	—	—	—	—	0	-150	0	-200	80	50	25	20	15	80	50	25	20	15	

Notes⁽¹⁾ For accuracy class P2 and other classes without a numerical description, the highest grade numerical value among the lower accuracy classes in the same nominal bore diameter range is applied.

⁽²⁾ For High Rigidity Type Crossed Roller Bearings (V), the tolerances for deviation of a single inner ring width are applicable to those of a single outer ring width.

Remark The accuracy specified in this table is not applicable to Mounting Holed Type High Rigidity Crossed Roller Bearings (V), Slim Type Crossed Roller Bearings and Super Slim Type Crossed Roller Bearings.

Table 7 Tolerances and allowable values of outer ring

unit: μ m

Nominal outside diameter mm	$\Delta_{Dmp}^{(1)}$ Single plane mean outside dia. deviation										K_{ea} Radial run-out of assembled bearing outer ring					S_{ea} Assembled bearing outer ring face run-out with raceway				
	Class 0 RP6-2		P6		P5		P4		Class 0	P6	P5	P4 ⁽²⁾	P2 ⁽²⁾	Class 0	P6	P5	P4 ⁽²⁾	P2 ⁽²⁾		
	Over	Incl.	High	Low	High	Low	High	Low											High	Low
30	50	0	-11	0	-9	0	-7	0	-6	20	10	7	5	2.5	20	10	7	5	2.5	
50	80	0	-13	0	-11	0	-9	0	-7	25	13	8	5	4	25	13	8	5	4	
80	120	0	-15	0	-13	0	-10	0	-8	35	18	10	6	5	35	18	10	6	5	
120	150	0	-18	0	-15	0	-11	0	-9	40	20	11	7	5	40	20	11	7	5	
150	180	0	-25	0	-18	0	-13	0	-10	45	23	13	8	5	45	23	13	8	5	
180	250	0	-30	0	-20	0	-15	0	-11	50	25	15	10	7	50	25	15	10	7	
250	315	0	-35	0	-25	0	-18	0	-13	60	30	18	11	7	60	30	18	11	7	
315	400	0	-40	0	-28	0	-20	—	—	70	35	20	—	—	70	35	20	—	—	
400	500	0	-45	0	-33	0	-23	—	—	80	40	23	—	—	80	40	23	—	—	
500	630	0	-50	0	-38	0	-28	—	—	100	50	25	—	—	100	50	25	—	—	
630	800	0	-75	0	-45	—	—	—	—	120	60	30	—	—	120	60	30	—	—	
800	1000	0	-100	0	-60	—	—	—	—	120	75	35	—	—	120	75	35	—	—	
1000	1030	0	-125	—	—	—	—	—	—	120	75	35	—	—	120	75	35	—	—	

Notes⁽¹⁾ For accuracy class P2 and other classes without a numerical description, the highest grade numerical value among the lower accuracy classes in the same nominal bore diameter range is applied.

⁽²⁾ P4 and P2 apply to High Rigidity Type Crossed Roller Bearings (V). For Standard Type Crossed Roller Bearings, the tolerance values for P5 are applicable to P4 and P2.

Remark The accuracy specified in this table is not applicable to Mounting Holed Type High Rigidity Crossed Roller Bearings (V), Slim Type Crossed Roller Bearings and Super Slim Type Crossed Roller Bearings.

Table 8 Tolerances and allowable values of Super Slim Type Crossed Roller Bearings unit: μm

d Nominal bore diameter mm	Δ_{dmp} Single plane mean bore dia. deviation		Δ_{Dmp} Single plane mean outside dia. deviation		Δ_{Bs} and Δ_{Cs} Deviations of a single inner ring width and outer ring width		K_{ia} and S_{ia} Radial and axial run-out of assembled bearing inner ring	K_{ea} and S_{ea} Radial and axial run-out of assembled bearing outer ring
	High	Low	High	Low	High	Low		
	mm		mm		mm		mm	mm
20	0	-10	0	-11	0	-75	13	20
30	0	-10	0	-11	0	-75	13	20
40	0	-12	0	-13	0	-75	15	25
50	0	-12	0	-13	0	-75	15	25

Table 9 Tolerances and allowable values of Slim Type Crossed Roller Bearings unit: μm

d Nominal bore diameter mm	Δ_{dmp} Single plane mean bore dia. deviation		Δ_{Dmp} Single plane mean outside dia. deviation		Δ_{Bs} and Δ_{Cs} Deviations of a single inner ring width and outer ring width		K_{ia} and S_{ia} Radial and axial run-out of assembled bearing inner ring	K_{ea} and S_{ea} Radial and axial run-out of assembled bearing outer ring
	High	Low	High	Low	High	Low		
	mm		mm		mm		mm	mm
50	0	-15	0	-13	0	-127	13	13
60	0	-15	0	-13	0	-127	13	13
70	0	-15	0	-15	0	-127	15	15
80	0	-20	0	-15	0	-127	15	15
90	0	-20	0	-15	0	-127	15	15
100	0	-20	0	-15	0	-127	15	15
110	0	-20	0	-20	0	-127	20	20
120	0	-25	0	-20	0	-127	20	20
130	0	-25	0	-25	0	-127	25	25
140	0	-25	0	-25	0	-127	25	25
150	0	-25	0	-25	0	-127	25	25
160	0	-25	0	-25	0	-127	25	25
170	0	-25	0	-30	0	-127	25	25
180	0	-30	0	-30	0	-127	30	30
190	0	-30	0	-30	0	-127	30	30
200	0	-30	0	-30	0	-127	30	30

Table 10.1 Tolerances and allowable values of inner rings of Mounting Holed Type High Rigidity Crossed Roller Bearings (V) unit: μm

d Nominal bore diameter mm	Δ_{dmp} Single plane mean bore dia. deviation										Δ_{Bs} Deviations of a single inner ring width		K_{ia} Radial run-out of assembled bearing inner ring					S_{ia} Assembled bearing inner ring face run-out with raceway						
	Class 0 RP6-2										Class 0 RP6-2		Class 0 RP6-2					Class 0 RP6-2						
	High		Low		High		Low		High		Low		High		Low		High		Low		High		Low	
	Over	Incl.	High	Low	High	Low	High	Low	High	Low	High	Low	Class	RP6	RP5	RP4	RP2	Class	RP6	RP5	RP4	RP2		
-	20	0	-10	0	-8	0	-6	0	-5	0	-75	13	8	4	3	2.5	13	8	4	3	2.5			
20	30	0	-10	0	-8	0	-6	0	-5	0	-75	15	10	5	4	2.5	15	10	5	4	2.5			
30	35	0	-12	0	-10	0	-8	0	-6	0	-75	15	10	5	4	2.5	15	10	5	4	2.5			
35	50	0	-12	0	-10	0	-8	0	-6	0	-75	20	10	5	4	2.5	20	10	5	4	2.5			
50	65	0	-15	0	-12	0	-9	0	-7	0	-75	20	10	5	4	2.5	20	10	5	4	2.5			
65	80	0	-15	0	-12	0	-9	0	-7	0	-75	25	13	6	5	2.5	25	13	6	5	2.5			
80	100	0	-20	0	-15	0	-10	0	-8	0	-75	25	13	6	5	2.5	25	13	6	5	2.5			
100	120	0	-20	0	-15	0	-10	0	-8	0	-75	30	18	8	6	2.5	30	18	8	6	2.5			

Table 10.2 Tolerances and allowable values of outer rings of Mounting Holed Type High Rigidity Crossed Roller Bearings (V) unit: μm

D Nominal outside diameter mm	Δ_{Dmp} Single plane mean outside dia. deviation										Δ_{Cs} Deviations of a single outer ring width		K_{ea} Radial run-out of assembled bearing outer ring					S_{ea} Assembled bearing outer ring face run-out with raceway						
	Class 0 RP6-2										Class 0 RP6-2		Class 0 RP6-2					Class 0 RP6-2						
	High		Low		High		Low		High		Low		High		Low		High		Low		High		Low	
	Over	Incl.	High	Low	High	Low	High	Low	High	Low	High	Low	Class	RP6	RP5	RP4	RP2	Class	RP6	RP5	RP4	RP2		
50	60	0	-13	0	-11	0	-9	0	-7	0	-75	20	10	7	5	2.5	20	10	7	5	2.5			
60	80	0	-13	0	-11	0	-9	0	-7	0	-75	25	13	8	5	4	25	13	8	5	4			
80	95	0	-15	0	-13	0	-10	0	-8	0	-75	25	13	8	5	4	25	13	8	5	4			
95	120	0	-15	0	-13	0	-10	0	-8	0	-75	35	18	10	6	5	35	18	10	6	5			
120	140	0	-18	0	-15	0	-11	0	-9	0	-75	35	18	10	6	5	35	18	10	6	5			
140	150	0	-18	0	-15	0	-11	0	-9	0	-75	40	20	11	7	5	40	20	11	7	5			
150	165	0	-25	0	-18	0	-13	0	-10	0	-75	40	20	11	7	5	40	20	11	7	5			
165	180	0	-25	0	-18	0	-13	0	-10	0	-75	45	23	13	8	5	45	23	13	8	5			
180	210	0	-30	0	-20	0	-15	0	-11	0	-75	45	23	13	8	5	45	23	13	8	5			
210	240	0	-30	0	-20	0	-15	0	-11	0	-75	50	25	15	10	7	50	25	15	10	7			

Clearance

The radial internal clearances of Crossed Roller Bearings, Super Slim Type Crossed Roller Bearings, Slim Type Crossed Roller Bearings and Mounting Holed Type High Rigidity Crossed Roller Bearings (V) are shown below in Table 11.1-11.4.

Table 11.1 Radial internal clearances unit: μm

d Nominal bore diameter mm	Radial internal clearance						
	T1		C1		C2		
	Min.	Max.	Min.	Max.	Min.	Max.	
-	30	-10	0	0	10	10	20
30	40	-10	0	0	10	10	20
40	50	-10	0	0	10	10	25
50	65	-10	0	0	10	10	25
65	80	-10	0	0	15	15	30
80	100	-10	0	0	15	15	35
100	120	-15	0	0	15	15	35
120	140	-15	0	0	20	20	45
140	160	-15	0	0	20	20	50
160	200	-15	0	0	20	20	50
200	250	-20	0	0	25	25	60
250	315	-20	0	0	25	25	60
315	400	-25	0	0	30	30	70
400	500	-30	0	0	40	40	85
500	630	-30	0	0	50	50	100
630	710	-30	0	0	60	60	120
710	800	-40	0	0	70	70	140

Remark This table is not applicable to Super Slim Type Crossed Roller Bearings, Slim Type Crossed Roller Bearings and Mounting Holed Type High Rigidity Crossed Roller Bearings (V).

Table 11.2 Radial internal clearances for Super Slim Type Crossed Roller Bearings unit: μm

d Nominal bore diameter of bearing mm	Radial internal clearance	
	C1	
	Min.	Max.
20	0	15
30	0	15
40	0	15
50	0	15

Table 11.3 Radial internal clearances of Slim Type Crossed Roller Bearings unit: μm

d Nominal bore diameter mm	Radial internal clearance					
	T1		C1		Normal	
	Min.	Max.	Min.	Max.	Min.	Max.
50	-8	0	0	15	30	56
60	-8	0	0	15	30	56
70	-8	0	0	15	30	56
80	-8	0	0	15	41	66
90	-8	0	0	15	41	66
100	-8	0	0	15	41	66
110	-8	0	0	15	41	66
120	-8	0	0	15	51	76
130	-8	0	0	15	51	76
140	-8	0	0	15	51	76
150	-8	0	0	15	51	76
160	-10	0	0	20	51	76
170	-10	0	0	20	51	76
180	-10	0	0	20	61	86
190	-10	0	0	20	61	86
200	-10	0	0	20	61	86

J
CRBH
CRBC
CRBT
CRBS
CRBF

Table 11.4 Radial internal clearances of Mounting Holed Type High Rigidity Crossed Roller Bearings (V)
unit: μm

Nominal bore diameter mm	Radial internal clearance							
			T1		C1		C2	
	Over	Incl.	Min.	Max.	Min.	Max.	Min.	Max.
—	20	—	10	0	0	10	10	20
20	25	—	10	0	0	10	10	20
25	35	—	10	0	0	10	10	25
35	65	—	10	0	0	15	15	30
65	80	—	10	0	0	15	15	35
80	95	—	15	0	0	15	15	35
95	110	—	15	0	0	20	20	45
110	125	—	15	0	0	20	20	50

Fit

The standard fits of Crossed Roller Bearings are shown in Table 12.1, and recommended fits for Slim Type Crossed Roller Bearings with normal clearances are shown in Table 12.2. For Super Slim Type Crossed Roller Bearings, it is recommended to use a slight interference fit adjusted to the actual measured dimensions. For large bearings, fit based on the actual measured dimensions of the bearings is recommended, and fit allowance should be chosen as small as possible in accordance with the tolerance class given in Table 12.1. When complex loads or shock loads are applied or when high rotational accuracy and rigidity of the bearing are required, it is recommended to use a slight interference fit adjusted to the actual measured dimensions for both inner and outer rings.

For the interference fit, the radial internal clearance after the fit decreases by approximately 70% to 90% of the interference amount. To avoid excessive pre-load due to fit, it is recommended to use a slight interference fit adjusted to the actual measured dimensions for both T1 and C1 clearances.

Table 12.1 Recommended fits for Crossed Roller Bearings under normal load

Radial internal clearance	Tolerance class			
	Inner ring rotating load		Outer ring rotating load	
	Shaft	Housing bore	Shaft	Housing bore
C1 clearance	h5	H7	g5	J7 ⁽¹⁾
C2 clearance	j5	H7	g5	J7 ⁽¹⁾

Note⁽¹⁾ It is recommended that a slight interference fit adjusted to the actual measured dimensions of the bearing is used.

Table 12.2 Recommended fits for Slim Type Crossed Roller Bearings with normal clearances

(Dimensional tolerances of shaft and housing bore)

unit: μm

Nominal bore diameter mm	Inner ring rotating load				Outer ring rotating load			
	Shaft		Housing bore		Shaft		Housing bore	
	High	Low	High	Low	High	Low	High	Low
50	+ 15	0	+ 13	0	- 15	- 30	- 13	- 25
60	+ 15	0	+ 13	0	- 15	- 30	- 13	- 25
70	+ 15	0	+ 15	0	- 15	- 30	- 15	- 30
80	+ 20	0	+ 15	0	- 20	- 40	- 15	- 30
90	+ 20	0	+ 15	0	- 20	- 40	- 15	- 30
100	+ 20	0	+ 15	0	- 20	- 40	- 15	- 30
110	+ 20	0	+ 20	0	- 20	- 40	- 20	- 40
120	+ 25	0	+ 20	0	- 25	- 50	- 20	- 40
130	+ 25	0	+ 25	0	- 25	- 50	- 25	- 50
140	+ 25	0	+ 25	0	- 25	- 50	- 25	- 50
150	+ 25	0	+ 25	0	- 25	- 50	- 25	- 50
160	+ 25	0	+ 25	0	- 25	- 50	- 25	- 50
170	+ 25	0	+ 30	0	- 25	- 50	- 30	- 60
180	+ 30	0	+ 30	0	- 30	- 60	- 30	- 60
190	+ 30	0	+ 30	0	- 30	- 60	- 30	- 60
200	+ 30	0	+ 30	0	- 30	- 60	- 30	- 60

Allowable rotational speed

Allowable rotational speeds of Crossed Roller Bearings are affected by mounting and operating conditions. The values in general operation are shown in Table 13.

Table 13 d_{mn} values⁽¹⁾ of Crossed Roller Bearings

Type	Lubricant	
	Grease	Oil
With cage or with separator	Open type	75 000
	Sealed type	60 000
Full complement	Open type	50 000
	Sealed type	40 000

Note⁽¹⁾ d_{mn} value = $d_m \times n$
where, d_m : Mean value of bearing bore and outside diameters, mm
 n : Number of rotations per minute, min⁻¹

Rotational torque

Rotational torque of IKO Crossed Roller Bearings are lower than that of plain bearings and the difference between the static torque and the dynamic (kinetic) torque is small. Therefore, these bearings minimize power consumption and operating temperature rise of machinery and increase the overall efficiency of machines.

The rotational torque is affected by many factors, but the following equations can be used expediently.

$$T = \mu P_{Or} \frac{D_{pw}}{2}$$

where, T : Rotational torque, N·mm
 μ : Friction coefficient (Approx. 0.010)
 P_{Or} : Static equivalent radial load, N
 D_{pw} : Pitch circle diameter, mm

$$\left(D_{pw} \doteq \frac{d + D}{2} \right)$$

Lubrication

These bearings are generally lubricated with grease. Grease is supplied through the clearance between the inner ring and the outer ring.

Grease specification is shown in Table 14, ALVANIA GREASE EP2 (SHOWA SHELL SEKIYU K.K) is prepacked as the lubricating grease.

For bearings without prepacked grease, supply grease or oil for use. Operating without grease or oil will increase the wear of the rolling contact surfaces and cause a short bearing life.

When using a special grease, carefully examine the grease properties and contents such as base oil viscosity and extreme pressure additives. In this case, please contact IKO.

Table 14 Bearings with prepacked grease

○: With prepacked grease ×: Without prepacked grease

Model code	Seal specification		
	Open type (No symbol)	Sealed type (UU)	One side sealed type (U)
CRBH ... A	×	○	×
CRBHV ... A	×	○	—
CRBC	×	○	×
CRB	×	○	×
CRBT ... A	○	—	—
CRBS	×	—	—
CRBS ... A	—	○	×
CRBS ... V	×	○	×
CRBF ... A	×	○	×
CRBFV ... A	×	○	—

Oil Hole

For Crossed Roller Bearings, oil holes and oil grooves can be provided on bearing rings if requested. Not applicable to the Super Slim Type. When an oil hole is required on the outer ring, attach "-OH" before the clearance symbol in the identification number. When an oil hole and an oil groove are required on the outer ring, attach "-OG" at the same place in the identification number. For an oil hole on the inner ring, attach "/OH", and for an oil hole and an oil groove on the inner ring, attach "/OG", at the same place in the identification number. High Rigidity Type Crossed Roller Bearings (V) and Mounting Holed Type High Rigidity Type Crossed Roller Bearings (V) have an oil groove and two oil holes on the outer ring as standard. Table 15 shows availability of oil holes for each bearing type.

Table 15 Oil holes

Bearing type	Oil hole code			
	/nOH	/nOG	-nOH	-nOG
CRBH(V) ... A	○	○	—	— ⁽¹⁾
CRBC	○	○	○	○
CRB	○	○	○	○
CRBT ... A	—	—	—	—
CRBS	○	—	○	—
CRBS ... A	○	—	○	—
CRBS ... V	○	—	○	—
CRBF(V) ... A	—	—	—	— ⁽¹⁾

Notes⁽¹⁾ CRBH(V) ... A and CRBF(V) ... A are provided with an oil groove and two oil holes on the outer ring.

Remark n denotes the number of oil holes not exceeding 4. For one oil hole, number is not indicated. When preparing multiple oil holes, please contact IKO.

Example 1 When the inner ring has 4 oil holes
CRBC 10020 / 4OH C1

4 Oil holes
In inner ring

Example 2 When the outer ring has a single oil hole
CRBC 10020 - OH C1

1 Oil hole
In outer ring

Operating Temperature Range

The operating temperature range for Crossed Roller Bearings is $-20^{\circ}\text{C} \sim +120^{\circ}\text{C}$. However, the maximum allowable temperature for types with separator and with seal is $+110^{\circ}\text{C}$, and $+100^{\circ}\text{C}$ when they are continuously operated.

Mounting

When the rigidity of the mounting parts is not sufficient, stress concentration will occur at the contact area between the rollers and raceways, and the bearing performance will be deteriorated significantly. Therefore, it is necessary to carefully examine the rigidity of housing and the strength of fixing bolts when a large moment will be applied. The shoulder height diameters (d_a and D_a) that are related to mounting should certainly satisfy the values shown in the dimension tables. When these dimensions are incorrect, deformations of inner and outer rings will occur and the bearing performance will be deteriorated remarkably.

1. Other than Mounting Holed Type High Rigidity Crossed Roller Bearings (V)

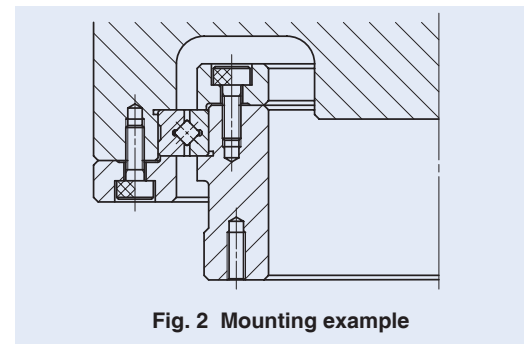

Fig. 2 Mounting example

① The inner and outer rings should be securely fixed in the axial direction by using fixing plates, etc. Recommended thickness of the fixing plate is 1/2 or more of the bearing width B . The dimensions in the axial direction of the housing bore and the fixing

plates should be determined to get a secure fixing while considering the dimension of bearing width which is given a minus tolerance. (See Fig.2)

- ② The depth of the housing bore is recommended to be equal to or larger than the bearing width.
- ③ Separation prevention bolts for the outer ring of Standard Type Crossed Roller Bearings are provided to prevent separation of two halves of the outer ring during transportation or mounting. When mounting, they should be loosened slightly.
- ④ High Rigidity Type Crossed Roller Bearings (V), Super Slim Type Crossed Roller Bearings and Slim Type Crossed Roller Bearings have a plug for hole for inserting rollers. When mounting the bearings, locate the plug at a position that is not included in the maximum loading zone. The plug location can be found by the pin pressed at the side of the outer ring.

2. Mounting Holed Type High Rigidity Crossed Roller Bearings (V)

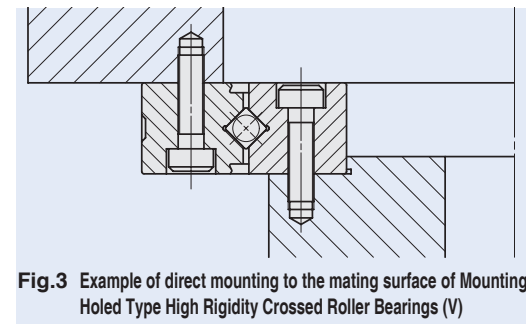

Fig.3 Example of direct mounting to the mating surface of Mounting Holed Type High Rigidity Crossed Roller Bearings (V)

① Mounting Holed Type High Rigidity Crossed Roller Bearings (V) can be mounted directly to the mounting surface by fixing bolts. (See Fig. 3)

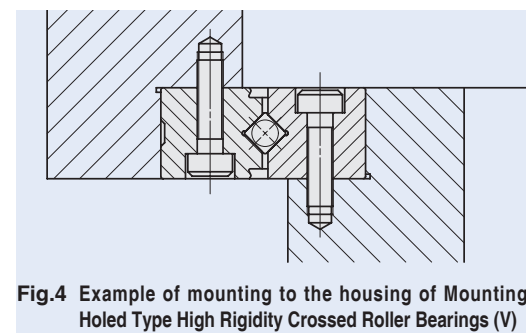

Fig.4 Example of mounting to the housing of Mounting Holed Type High Rigidity Crossed Roller Bearings (V)

- ② If large number of radial load and/or moment is expected, it is recommended to prepare flange part. (See Fig.4)
- ③ Mounting Holed Type High Rigidity Crossed Roller Bearings (V) have a plug for hole for inserting cylindrical rollers. When mounting the bearings, locate the plug at a position that is not included in the maximum loading zone. The plug location can be found by the pin pressed at the side of the outer ring.

Tightening torque of mounting bolts

The standard tightening torque values for Mounting Holed Type High Rigidity Crossed Roller Bearings (V) mounting bolts are shown in Table 16. When machines or equipment are subjected to severe vibration, shock, large fluctuating load, or moment load, the bolts should be tightened with a torque 1.2 to 1.5 times higher than the standard torque values shown. If the mating member material is cast iron or aluminum, reduce the tightening torque depending on the strength characteristics of the mating member material. Please do not tighten with too much torque as abnormal frictional torque or short life may occur.

Table 16 Tightening torque of mounting bolts

Bolt size	Tightening torque N · m
M3 × 0.5	1.7
M4 × 0.7	4.0
M5 × 0.8	7.9
M8 × 1.25	32

Above values are for Carbon steel bolt (Strength division 12.9)

Double Row Angular Contact Roller Bearing

We manufacture Double Row Angular Contact Roller Bearings to order. If needed, please contact **IKO**. Double Row Angular Contact Roller Bearings have a large number of cylindrical rollers with a large contact area with a raceway and an excellent load capability, between the inner and outer rings arranged in a double row of raceways. This underpins even higher rigidity and lower torque than High Rigidity Type Crossed Roller Bearings (V). The mounting holes in both inner and outer rings facilitate installation to your machines and equipment. Further, the integrated structure (non split) constructed in both inner and outer rings can avoid installation errors, yielding extra-high-rigidity and high-accuracy guiding performance without being affected by other peripheral structures such as housing or pressure plate.

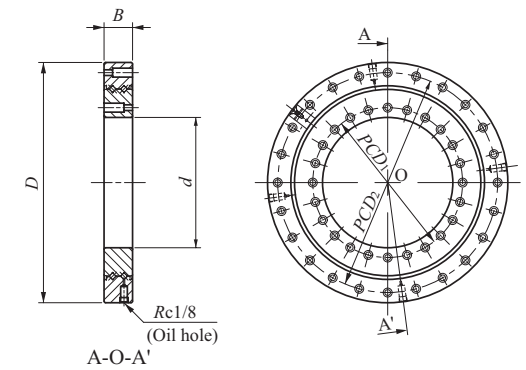
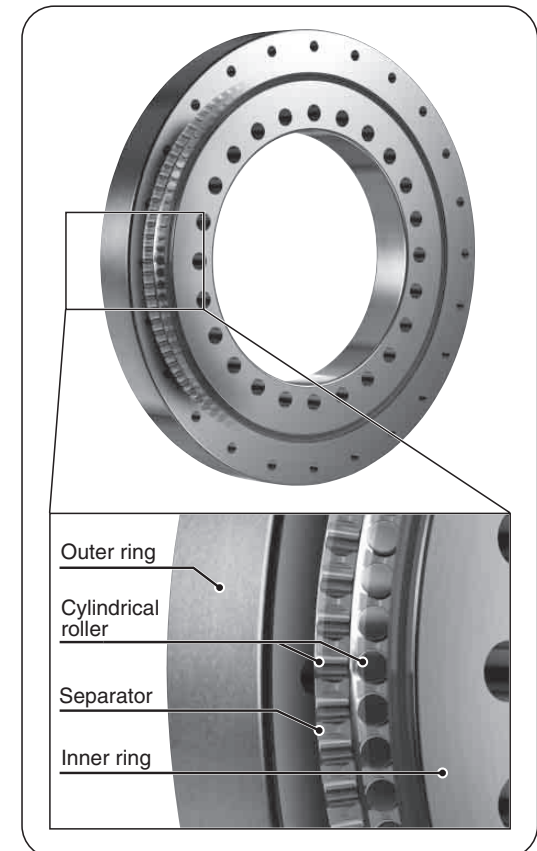

Fig. 5 Manufacturing example

Table 17 Example of manufacturing dimensions

Boundary dimensions mm						Basic dynamic load rating	Basic static load rating
d	D	B	r_{min}	PCD ₁	PCD ₂	C N	C ₀ N
160	295	35	2	184	270	60 300	167 000
210	380	40	2.5	240	350	108 000	313 000
350	540	50	2.5	385	505	235 000	725 000

Structure of Double-acting Angular Roller Bearing



J

CRBH
CRBC
CRB
CRBT
CRBS
CRBF

CROSSED ROLLER BEARINGS

High Rigidity Type Crossed Roller Bearings (V) **Open Type/With Separator**
Sealed Type/With Separator

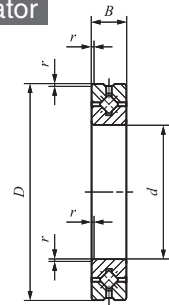
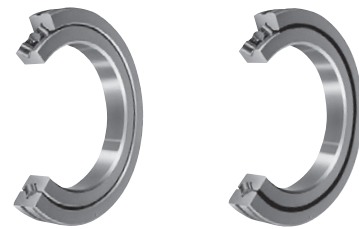

CRBH(V) ... A

Shaft dia. 20 – 300mm

Shaft dia. mm	Identification number High Rigidity Type Crossed Roller Bearings		Identification number High Rigidity Type Crossed Roller Bearings V		Mass (Ref.) kg	Boundary dimensions mm	
	Open Type	Seald Type	Open Type	Seald Type		d	D
20	CRBH 208 A	CRBH 208 A UU	—	—	0.04	20	36
25	CRBH 258 A	CRBH 258 A UU	—	—	0.05	25	41
30	CRBH 3010 A	CRBH 3010 A UU	CRBHV 3010 A	CRBHV 3010 A UU	0.12	30	55
35	CRBH 3510 A	CRBH 3510 A UU	CRBHV 3510 A	CRBHV 3510 A UU	0.13	35	60
40	CRBH 4010 A	CRBH 4010 A UU	CRBHV 4010 A	CRBHV 4010 A UU	0.15	40	65
45	CRBH 4510 A	CRBH 4510 A UU	CRBHV 4510 A	CRBHV 4510 A UU	0.16	45	70
50	CRBH 5013 A	CRBH 5013 A UU	CRBHV 5013 A	CRBHV 5013 A UU	0.29	50	80
60	CRBH 6013 A	CRBH 6013 A UU	CRBHV 6013 A	CRBHV 6013 A UU	0.33	60	90
70	CRBH 7013 A	CRBH 7013 A UU	CRBHV 7013 A	CRBHV 7013 A UU	0.38	70	100
80	CRBH 8016 A	CRBH 8016 A UU	CRBHV 8016 A	CRBHV 8016 A UU	0.74	80	120
90	CRBH 9016 A	CRBH 9016 A UU	CRBHV 9016 A	CRBHV 9016 A UU	0.81	90	130
100	CRBH 10020 A	CRBH 10020 A UU	CRBHV 10020 A	CRBHV 10020 A UU	1.45	100	150
110	CRBH 11020 A	CRBH 11020 A UU	CRBHV 11020 A	CRBHV 11020 A UU	1.56	110	160
120	CRBH 12025 A	CRBH 12025 A UU	CRBHV 12025 A	CRBHV 12025 A UU	2.62	120	180
130	CRBH 13025 A	CRBH 13025 A UU	CRBHV 13025 A	CRBHV 13025 A UU	2.82	130	190
140	CRBH 14025 A	CRBH 14025 A UU	CRBHV 14025 A	CRBHV 14025 A UU	2.96	140	200
150	CRBH 15025 A	CRBH 15025 A UU	CRBHV 15025 A	CRBHV 15025 A UU	3.16	150	210
200	CRBH 20025 A	CRBH 20025 A UU	CRBHV 20025 A	CRBHV 20025 A UU	4.0	200	260
250	CRBH 25025 A	CRBH 25025 A UU	CRBHV 25025 A	CRBHV 25025 A UU	4.97	250	310
300	CRBH 30025 A	CRBH 30025 A UU			5.29	300	360

Note(1) Minimum allowable single value of chamfer dimension r

Remarks1. The outer ring has an oil groove and two oil holes.

2. No grease is prepacked for Open Type. Perform proper lubrication. Grease is prepacked for Sealed Type.

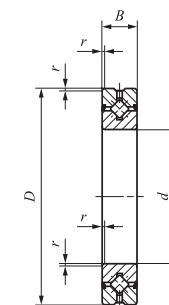

CRBH(V) ... AUU

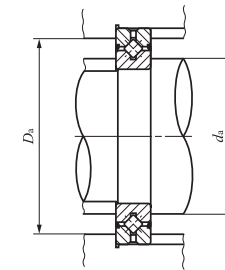

Boundary dimensions mm		Mounting dimensions mm		Basic dynamic load rating C N	Basic static load rating C ₀ N
B	r ⁽¹⁾ _{min}	d _a	D _a		
8	0.3	24	31	2 910	2 430
8	0.3	29	36	3 120	2 810
10	0.3	36.5	48.5	7 600	8 370
10	0.3	41.5	53.5	7 900	9 130
10	0.3	46.5	58.5	8 610	10 600
10	0.3	51.5	63.5	8 860	11 300
13	0.6	56	74	17 300	20 900
13	0.6	66	84	18 800	24 300
13	0.6	76	94	20 100	27 700
16	0.6	88	112	32 100	43 400
16	0.6	98	122	33 100	46 800
20	0.6	110	140	50 900	72 200
20	0.6	120	150	52 400	77 400
25	1	132	168	73 400	108 000
25	1	142	178	75 900	115 000
25	1	152	188	81 900	130 000
25	1	162	198	84 300	138 000
25	1	212	248	92 300	169 000
25	1.5	262	298	102 000	207 000
25	1.5	312	348	112 000	245 000

J
 CRBH
 CRBC
 CRB
 CRBT
 CRBS
 CRBF

CROSSED ROLLER BEARINGS

Standard Type Crossed Roller Bearings

- Open Type/With Cage Open Type/Full Complement Type
- Sealed Type/With Cage Sealed Type/Full Complement Type

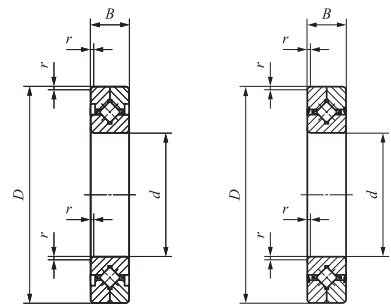

CRBC

CRBC...UU

Shaft dia. 30 – 200mm

Shaft dia. mm	Identification number				Mass (Ref.) kg	Boundary dimensions mm		
	With Cage		Full complement			d	D	B
	Open Type	Seald Type	Open Type	Seald Type				
30	CRBC 3010	CRBC 3010 UU	CRB 3010	CRB 3010 UU	0.12	30	55	10
40	CRBC 4010	CRBC 4010 UU	CRB 4010	CRB 4010 UU	0.15	40	65	10
50	CRBC 5013	CRBC 5013 UU	CRB 5013	CRB 5013 UU	0.29	50	80	13
60	CRBC 6013	CRBC 6013 UU	CRB 6013	CRB 6013 UU	0.33	60	90	13
70	CRBC 7013	CRBC 7013 UU	CRB 7013	CRB 7013 UU	0.38	70	100	13
80	CRBC 8016	CRBC 8016 UU	CRB 8016	CRB 8016 UU	0.74	80	120	16
90	CRBC 9016	CRBC 9016 UU	CRB 9016	CRB 9016 UU	0.81	90	130	16
100	CRBC 10020	CRBC 10020 UU	CRB 10020	CRB 10020 UU	1.45	100	150	20
110	CRBC 11020	CRBC 11020 UU	CRB 11020	CRB 11020 UU	1.56	110	160	20
120	CRBC 12025	CRBC 12025 UU	CRB 12025	CRB 12025 UU	2.62	120	180	25
130	CRBC 13025	CRBC 13025 UU	CRB 13025	CRB 13025 UU	2.82	130	190	25
140	CRBC 14025	CRBC 14025 UU	CRB 14025	CRB 14025 UU	2.96	140	200	25
150	CRBC 15025	CRBC 15025 UU	CRB 15025	CRB 15025 UU	3.16	150	210	25
	CRBC 15030	CRBC 15030 UU	CRB 15030	CRB 15030 UU	5.3	150	230	30
200	CRBC 20025	CRBC 20025 UU	CRB 20025	CRB 20025 UU	4.0	200	260	25
	CRBC 20030	—	CRB 20030	—	6.7	200	280	30
	CRBC 20035	—	CRB 20035	—	9.58	200	295	35

Note(1) Minimum allowable single value of chamfer dimension r

Remarks1. No oil hole is provided.

2. No grease is prepacked for Open Type. Perform proper lubrication. Grease is prepacked for Sealed Type.

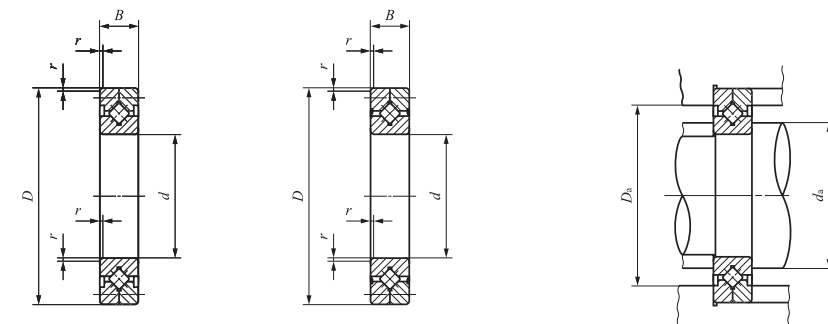

CRB

CRB...UU

r _{min} ⁽¹⁾	Mounting dimensions mm		CRBC		CRB	
	d _a	D _a	Basic dynamic load rating C N	Basic static load rating C ₀ N	Basic dynamic load rating C N	Basic static load rating C ₀ N
	0.3	34	44	3 830	4 130	5 290
0.3	44	54	4 280	5 140	5 980	8 040
0.6	55	71	10 700	12 600	14 200	18 400
0.6	64	81	11 600	14 600	15 400	21 500
0.6	75	91	12 300	16 700	17 000	25 500
0.6	86	107	18 200	25 500	24 300	37 500
1	98	118	19 400	28 600	25 900	42 100
1	108	134	31 500	45 100	39 400	61 100
1	118	144	33 500	50 700	41 200	66 700
1.5	132	164	47 700	70 500	59 900	95 400
1.5	140	172	49 200	74 800	61 000	99 800
1.5	151	183	50 700	79 200	64 100	108 000
1.5	160	192	53 800	87 700	65 000	113 000
1.5	166	202	69 200	108 000	85 900	144 000
2	208	239	60 200	110 000	75 300	148 000
2	218	262	108 000	178 000	133 000	234 000
2	221	274	137 000	215 000	168 000	282 000

J
CRBH
CRBC
CRB
CRBT
CRBS
CRBF

CROSSED ROLLER BEARINGS

Standard Type Crossed Roller Bearings

- Open Type/With Cage
- Open Type/Full Complement Type
- Sealed Type/With Cage
- Sealed Type/Full Complement Type

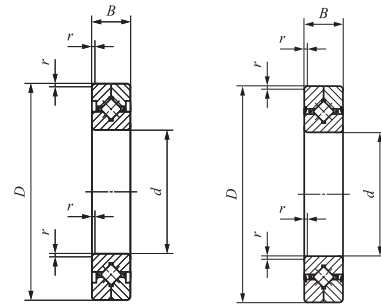

CRBC 25025
CRBC 30025 CRB 25025UU
CRB 30025UU

Shaft dia. 250 – 800mm

Shaft dia. mm	Identification number				Mass (Ref.) kg	Boundary dimensions mm		
	With Cage		Full complement			d	D	B
	Open Type	Seald Type	Open Type	Seald Type				
250	CRBC 25025	CRBC 25025 UU	CRB 25025	CRB 25025 UU	4.97	250	310	25
	CRBC 25030	—	CRB 25030	—	8.1	250	330	30
	CRBC 25040	—	CRB 25040	—	14.8	250	355	40
300	CRBC 30025	CRBC 30025 UU	CRB 30025	CRB 30025 UU	5.88	300	360	25
	CRBC 30035	—	CRB 30035	—	13.4	300	395	35
	CRBC 30040	—	CRB 30040	—	17.2	300	405	40
400	CRBC 40035	—	CRB 40035	—	14.5	400	480	35
	CRBC 40040	—	CRB 40040	—	23.5	400	510	40
	CRBC 40070	—	CRB 40070	—	72.4	400	580	70
500	CRBC 50040	—	CRB 50040	—	26.0	500	600	40
	CRBC 50050	—	CRB 50050	—	41.7	500	625	50
	CRBC 50070	—	CRB 50070	—	86.1	500	680	70
600	CRBC 60040	—	CRB 60040	—	30.6	600	700	40
	CRBC 60070	—	CRB 60070	—	102	600	780	70
	CRBC 600120	—	CRB 600120	—	274	600	870	120
700	CRBC 70045	—	CRB 70045	—	46.5	700	815	45
	CRBC 70070	—	CRB 70070	—	115	700	880	70
	CRBC 700150	—	CRB 700150	—	478	700	1 020	150
800	CRBC 80070	—	CRB 80070	—	109	800	950	70
	CRBC 800100	—	CRB 800100	—	247	800	1 030	100

Note(1) Minimum allowable single value of chamfer dimension r

Remarks1. No oil hole is provided.

2. No grease is prepacked for Open Type. Perform proper lubrication. Grease is prepacked for Sealed Type.

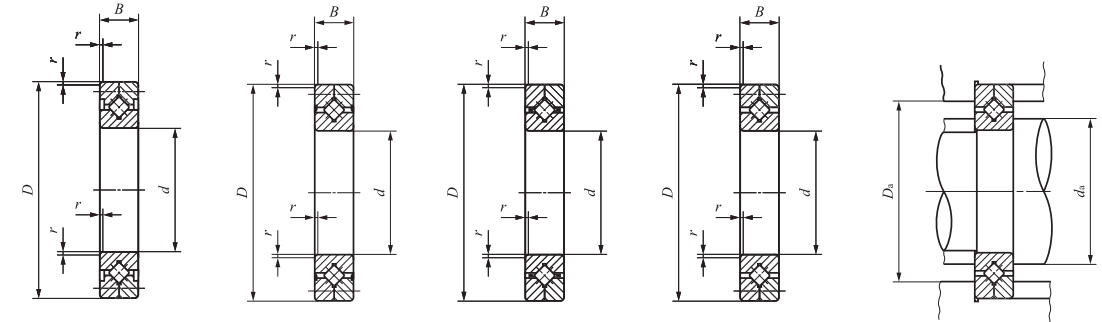

CRB 25025
CRB 30025 CRB 25025UU
CRB 30025UU CRBC CRB

r _{min} ⁽¹⁾	Mounting dimensions mm		CRBC		CRB	
	d _a	D _a	Basic dynamic load rating C N	Basic static load rating C ₀ N	Basic dynamic load rating C N	Basic static load rating C ₀ N
	2.5	259	290	67 200	136 000	83 900
2.5	265	310	116 000	208 000	146 000	283 000
2.5	271	330	179 000	299 000	215 000	382 000
2.5	310	341	73 800	162 000	91 900	217 000
2.5	318	372	163 000	299 000	205 000	408 000
2.5	321	381	194 000	351 000	235 000	451 000
2.5	414	457	133 000	300 000	165 000	400 000
2.5	423	483	222 000	455 000	270 000	590 000
2.5	430	532	470 000	811 000	576 000	1 060 000
2.5	517	573	212 000	497 000	259 000	648 000
2.5	531	592	247 000	561 000	306 000	747 000
2.5	530	633	536 000	1 020 000	653 000	1 330 000
3	621	676	231 000	581 000	287 000	774 000
3	630	734	591 000	1 230 000	700 000	1 540 000
3	643	817	1 250 000	2 210 000	1 490 000	2 800 000
3	730	785	250 000	681 000	313 000	917 000
3	731	834	630 000	1 390 000	766 000	1 810 000
3	751	953	1 660 000	3 010 000	1 980 000	3 820 000
4	831	907	417 000	1 090 000	513 000	1 440 000
4	840	972	936 000	2 040 000	1 140 000	2 640 000

J

CRBH
CRBC
CRB
CRBT
CRBS
CRBF

CROSSED ROLLER BEARINGS

Super Slim Type Crossed Roller Bearings **Open Type/With Separator**

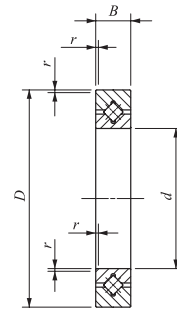

CRBT ... A

Shaft dia. 20 – 50mm

Shaft dia. mm	Identification number	Mass (Ref.) g	Boundary dimensions mm				Mounting dimensions mm		Basic dynamic load rating C N
			d	D	B	r ⁽¹⁾ _{min}	d _a	D _a	
20	CRBT 205 A	14.8	20	31	5	0.15	22.5	27	1 400
30	CRBT 305 A	20.7	30	41	5	0.15	32.5	37	1 770
40	CRBT 405 A	26.5	40	51	5	0.15	42.5	47	2 000
50	CRBT 505 A	32.3	50	61	5	0.15	52.5	57	2 280

Note⁽¹⁾ Minimum allowable single value of chamfer dimension r.
 Remarks1. No oil hole is provided.
 2. Grease is prepacked.

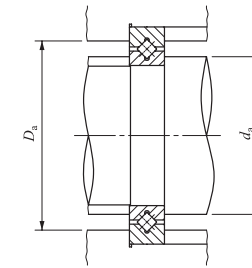

Basic static load rating C ₀ N
1 290
1 970
2 520
3 200

J

CRBH
CRBC
CRB
CRBT
CRBS
CRBF

CROSSED ROLLER BEARINGS

Slim Type Crossed Roller Bearings

Open Type/With Cage

Open Type/Full Complement Type

Sealed Type/With Separator

Sealed Type/Full Complement Type

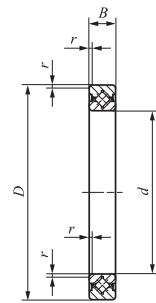

CRBS

Shaft dia. 50 – 200mm

Shaft dia. mm	Identification number					Mass (Ref.) g
	With Cage Open Type	With Separator Seald Type		Full complement		
		CRBS	CRBS	CRBS	CRBS	
50	CRBS 508	CRBS 508 A UU	CRBS 508 V	CRBS 508 V UU	84	
60	CRBS 608	CRBS 608 A UU	CRBS 608 V	CRBS 608 V UU	94	
70	CRBS 708	CRBS 708 A UU	CRBS 708 V	CRBS 708 V UU	108	
80	CRBS 808	CRBS 808 A UU	CRBS 808 V	CRBS 808 V UU	122	
90	CRBS 908	CRBS 908 A UU	CRBS 908 V	CRBS 908 V UU	135	
100	CRBS 1008	CRBS 1008 A UU	CRBS 1008 V	CRBS 1008 V UU	152	
110	CRBS 1108	CRBS 1108 A UU	CRBS 1108 V	CRBS 1108 V UU	163	
120	CRBS 1208	CRBS 1208 A UU	CRBS 1208 V	CRBS 1208 V UU	184	
130	CRBS 1308	CRBS 1308 A UU	CRBS 1308 V	CRBS 1308 V UU	199	
140	CRBS 1408	CRBS 1408 A UU	CRBS 1408 V	CRBS 1408 V UU	205	
150	CRBS 1508	CRBS 1508 A UU	CRBS 1508 V	CRBS 1508 V UU	220	
160	CRBS 16013	CRBS 16013 A UU	CRBS 16013 V	CRBS 16013 V UU	620	
170	CRBS 17013	CRBS 17013 A UU	CRBS 17013 V	CRBS 17013 V UU	675	
180	CRBS 18013	CRBS 18013 A UU	CRBS 18013 V	CRBS 18013 V UU	710	
190	CRBS 19013	CRBS 19013 A UU	CRBS 19013 V	CRBS 19013 V UU	740	
200	CRBS 20013	CRBS 20013 A UU	CRBS 20013 V	CRBS 20013 V UU	780	

Note⁽¹⁾ Minimum allowable single value of chamfer dimension *r*
⁽²⁾ No grease is prepacked. Perform proper lubrication.
⁽³⁾ Grease is prepacked.
 Remark No oil hole is provided.

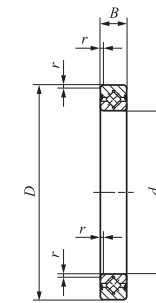

CRBS...AUU
...VUU

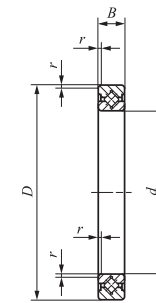

CRBS...V

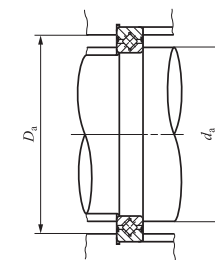

Boundary dimensions mm				Mounting dimensions mm		CRBS ⁽²⁾ With cage		CRBS...AUU ⁽³⁾ With Separator		CRBS...V ⁽²⁾ CRBS...VUU ⁽³⁾ Full complement	
<i>d</i>	<i>D</i>	<i>B</i>	<i>r</i> _{min} ⁽¹⁾	<i>d</i> _a	<i>D</i> _a	Basic dynamic load rating <i>C</i> _N	Basic static load rating <i>C</i> ₀ _N	Basic dynamic load rating <i>C</i> _N	Basic static load rating <i>C</i> ₀ _N	Basic dynamic load rating <i>C</i> _N	Basic static load rating <i>C</i> ₀ _N
50	66	8	0.4	54	61	4 900	6 170	4 680	5 810	6 930	9 800
60	76	8	0.4	64	71	5 350	7 310	5 350	7 310	7 600	11 700
70	86	8	0.4	74	81	5 740	8 440	5 740	8 440	8 190	13 600
80	96	8	0.4	84	91	6 130	9 590	6 130	9 590	8 790	15 500
90	106	8	0.4	94	101	6 490	10 700	6 490	10 700	9 310	17 400
100	116	8	0.4	104	111	6 850	11 900	6 530	11 100	9 850	19 300
110	126	8	0.4	114	121	7 160	13 000	6 850	12 300	10 300	21 200
120	136	8	0.4	124	131	7 530	14 100	7 070	13 000	10 900	23 000
130	146	8	0.4	134	141	7 860	15 300	7 270	13 800	11 200	24 600
140	156	8	0.4	144	151	8 060	16 400	7 510	14 900	11 700	26 800
150	166	8	0.4	154	161	8 350	17 500	7 810	16 000	12 100	28 700
160	186	13	0.6	166	179	20 300	39 900	19 400	37 700	26 900	58 200
170	196	13	0.6	176	189	20 900	42 200	20 000	39 900	27 800	61 600
180	206	13	0.6	186	199	21 500	44 600	21 900	45 700	28 600	65 200
190	216	13	0.6	196	209	22 100	46 900	22 900	49 200	29 300	68 600
200	226	13	0.6	206	219	22 500	49 300	23 300	51 600	30 000	72 200

J
 CRBH
 CRBC
 CRB
 CRBT
 CRBS
 CRBF

CROSSED ROLLER BEARINGS

Mounting Holed Type High Rigidity **Open Type/With Separator**
 Crossed Roller Bearings (V) **Sealed Type/With Separator**

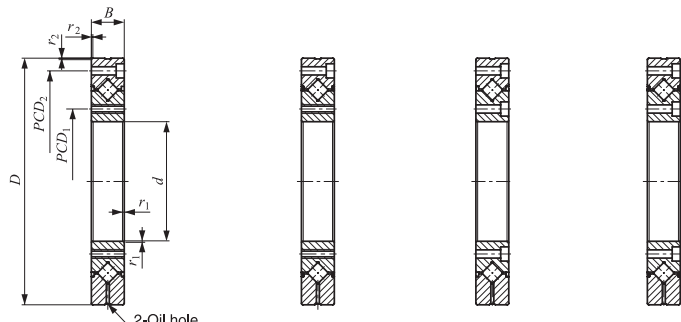

Shaft dia. 10 – 115mm

CRBF(V) ... AT CRBF(V) ... ATUU CRBF(V) ... A CRBF(V) ... AUU

Shaft dia. mm	Identification number		Identification number		Mass (Ref.) kg	Boundary dimensions mm		
	Open Type	Sealed Type	Open Type	Sealed Type		d	D	B
10	CRBF 108 AT	CRBF 108 AT UU	—	—	0.12	10	52	8
20	CRBF 2012 AT	CRBF 2012 AT UU	CRBFV 2012 AT	CRBFV 2012 AT UU	0.31	20	70	12
25	CRBF 2512 AT	CRBF 2512 AT UU	CRBFV 2512 AT	CRBFV 2512 AT UU	0.40	25	80	12
35	CRBF 3515 AT	CRBF 3515 AT UU	CRBFV 3515 AT	CRBFV 3515 AT UU	0.66	35	95	15
55	CRBF 5515 AT	CRBF 5515 AT UU	CRBFV 5515 AT	CRBFV 5515 AT UU	0.96	55	120	15
80	CRBF 8022 AT	CRBF 8022 AT UU	CRBFV 8022 AT	CRBFV 8022 AT UU	2.63	80	165	22
	CRBF 8022 A	CRBF 8022 A UU	CRBFV 8022 A	CRBFV 8022 A UU	2.60			
	CRBF 8022 AD	CRBF 8022 AD UU	CRBFV 8022 AD	CRBFV 8022 AD UU				
90	CRBF 9025 AT	CRBF 9025 AT UU	CRBFV 9025 AT	CRBFV 9025 AT UU	4.83	90	210	25
	CRBF 9025 A	CRBF 9025 A UU	CRBFV 9025 A	CRBFV 9025 A UU	4.67			
	CRBF 9025 AD	CRBF 9025 AD UU	CRBFV 9025 AD	CRBFV 9025 AD UU				
115	CRBF 11528 AT	CRBF 11528 AT UU	CRBFV 11528 AT	CRBFV 11528 AT UU	6.81	115	240	28
	CRBF 11528 A	CRBF 11528 A UU	CRBFV 11528 A	CRBFV 11528 A UU	6.63			
	CRBF 11528 AD	CRBF 11528 AD UU	CRBFV 11528 AD	CRBFV 11528 AD UU				

Note(1) Minimum allowable single value of chamfer diameter r_1 and r_2 .
 Remarks1. The outer ring has an oil groove and two oil holes.
 2. No grease is prepacked for Open Type. Perform proper lubrication. Grease is prepacked for Sealed Type.

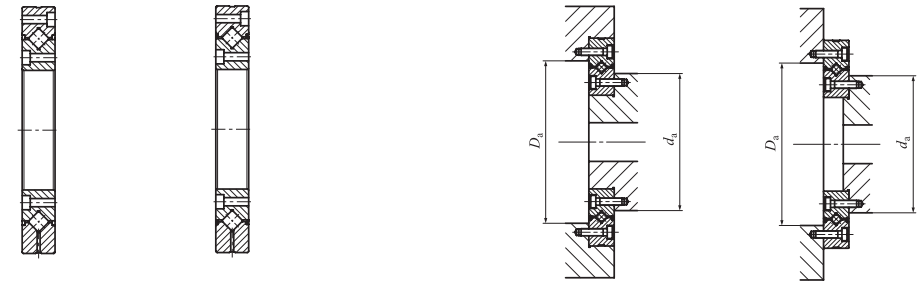

CRBF(V) ... AD CRBF(V) ... ADUU

Boundary dimensions mm	Mounting holes mm								Mounting dimensions mm		Basic dynamic load rating C N	Basic static load rating C ₀ N
	$r_{1min}^{(1)}$	$r_{2min}^{(1)}$	PCD_1	Inner ring Mounting holes	PCD_2	Inner ring Mounting holes	d_a	D_a				
0.3	0.3	16	4-M3 through	42	6- ϕ 3.4 through ϕ 6.5 counter bore depth 3.3	24	31	2 910	2 430			
0.3	0.3	28	6-M3 through	57	6- ϕ 3.4 through ϕ 6.5 counter bore depth 3.3	36.5	48.5	7 600	8 370			
0.6	0.6	35	6-M3 through	67	6- ϕ 3.4 through ϕ 6.5 counter bore depth 3.3	46.5	58.5	8 610	10 600			
0.6	0.6	45	8-M4 through	83	8- ϕ 4.5 through ϕ 8 counter bore depth 4.4	56	74	17 300	20 900			
0.6	0.6	65	8-M5 through	105	8- ϕ 5.5 through ϕ 9.5 counter bore depth 5.4	76	94	20 100	27 700			
0.6	1	97	10-M5 through	148	10- ϕ 5.5 through ϕ 9.5 counter bore depth 5.4	107	137	51 100	72 000			
			10- ϕ 5.5 through ϕ 9.5 counter bore depth 5.4									
1.5	1.5	112	12-M8 through	187	12- ϕ 9 through ϕ 14 counter bore depth 12	132	168	73 400	108 000			
			12- ϕ 9 through ϕ 14 counter bore depth 12									
1.5	1.5	139	12-M8 through	217	12- ϕ 9 through ϕ 14 counter bore depth 13.5	162	198	84 300	138 000			
			12- ϕ 9 through ϕ 14 counter bore depth 13.5									

J
 CRBH
 CRBC
 CRB
 CRBT
 CRBS
 CRBF