

T-HEAD BOLT

Article Nr. 21.1370/0

See the product on the website →

Download CAD Files →

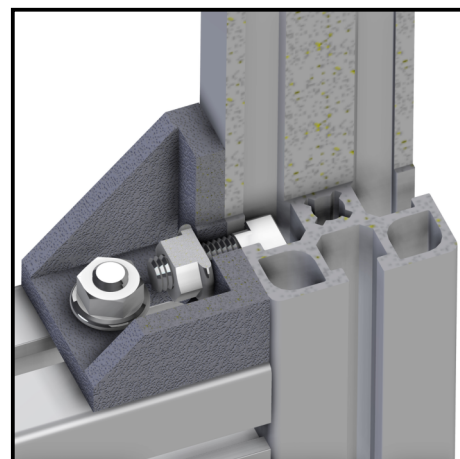
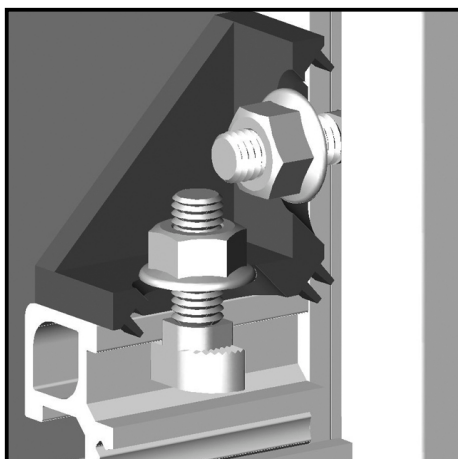
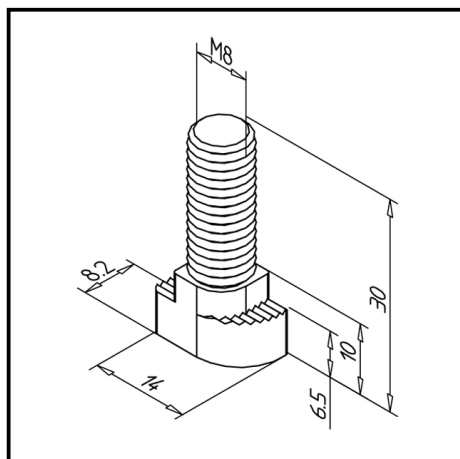

TECHN. DATA / ITEMS SUPPLIED

- Steel, galvanized
- Thread (d) : M 8
- Length (l) : 23.5 mm
- Weight = 0.013 kg/piece

APPLICATIONS

- Simple attachment of add-on parts or accessories on profiles
- Attachment of mounting angle:
45 x 90 GD-Z **part no.** [21.1397/0](#), 45 GD **part no.** [21.1133/0](#), 45 GD-Z **part no.** [21.1349/0](#), 90 GD-Z **partno.** [21.0978/0](#)

ASSEMBLY

- Insert the hammer screw in the profile groove, screw on nut M8
- When tightening the nut, the hammer head will turn crosswise
- **Recommended nut:** Hexagon nut self-locking with flange **part no.** [21.1334/0](#)