

DRAWING FOR REFERENCE: This is subject to change without notice  
08/11/2012

TO  
PCK

COUNT	DESCRIPTION OF REVISIONS	BY	CHKD	DATE	COUNT	DESCRIPTION OF REVISIONS	BY	CHKD	DATE
△					△				
△					△				
△					△				

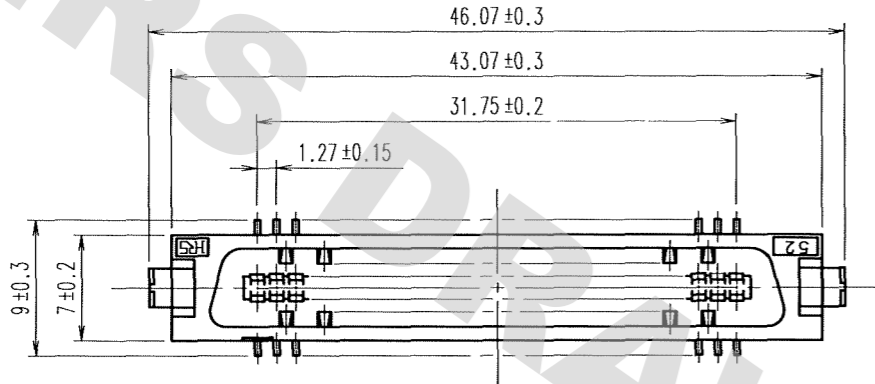

RECOMMENDED LAND PATTERN DIMENSION OF PCB (MOUNTING SIDE)

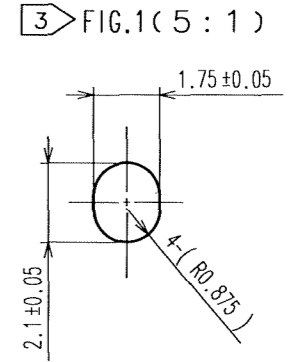
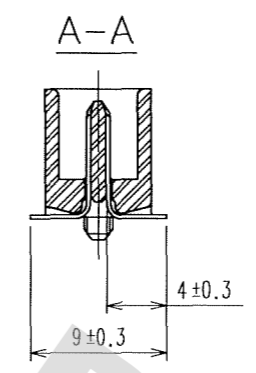
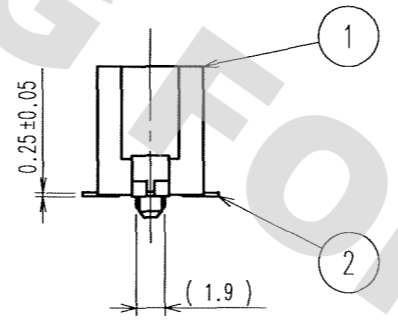
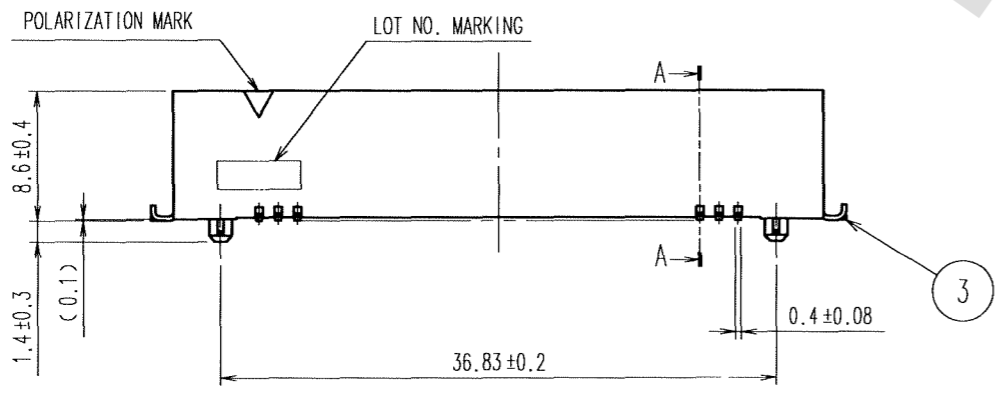
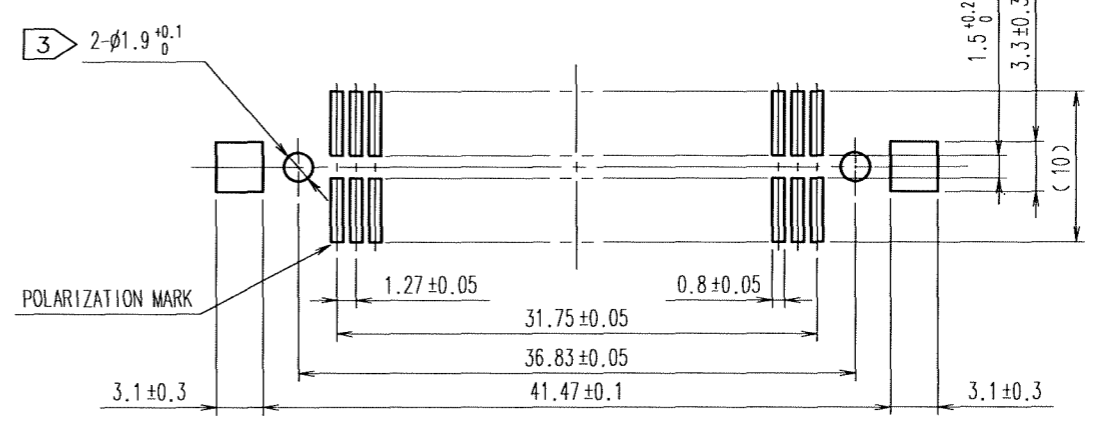

- NOTES
- 1 LEAD CO-PLANARITY SHALL BE 0.15 MAX.
  - 2 THE DIMENSIONS IN PARENTHESES ARE FOR REFERENCE.
  - 3 IN CASE OF THE AUTOMATED MOUNTING, RECOMMENDED HOLE DIAMETER OF BOSS IS SHOWN IN FIG.1.

3	BRASS	TIN-PLATING	2	PHOSPHOR BRONZE	CONTACT AREA: GOLD 0.2μ m min. LEAD AREA: TIN-PLATING 2μ m min. UNDER PLATING: NICKEL 2μ m min.
1	PPS	LIGHT BROWN (UL94V-0)			
NO.	MATERIAL	FINISH, REMARKS	NO.	MATERIAL	FINISH, REMARKS
CODE NO. (OLD) CL			DRAWN	DESIGNED	CHECKED
			A. SUZUKAWA	H. Nakamura	K. Ogoe
			06.02.08	06.02.13	06.02.13
			APPROVED	RELEASED	
			H. Okawa		
			06.02.13		
DRAWING NO. EDC3-082403-21			PART NO. FX2-52P-1.27SVL(71)		
SCALE 2 : 1			CODE NO. CL572-2054-5-71		
UNITS mm			HRS HIROSE ELECTRIC CO., LTD		
					1/1

F