

High Power Cylinder

Series RHC

ø20, ø25, ø32, ø40, ø50, ø63, ø80, ø100

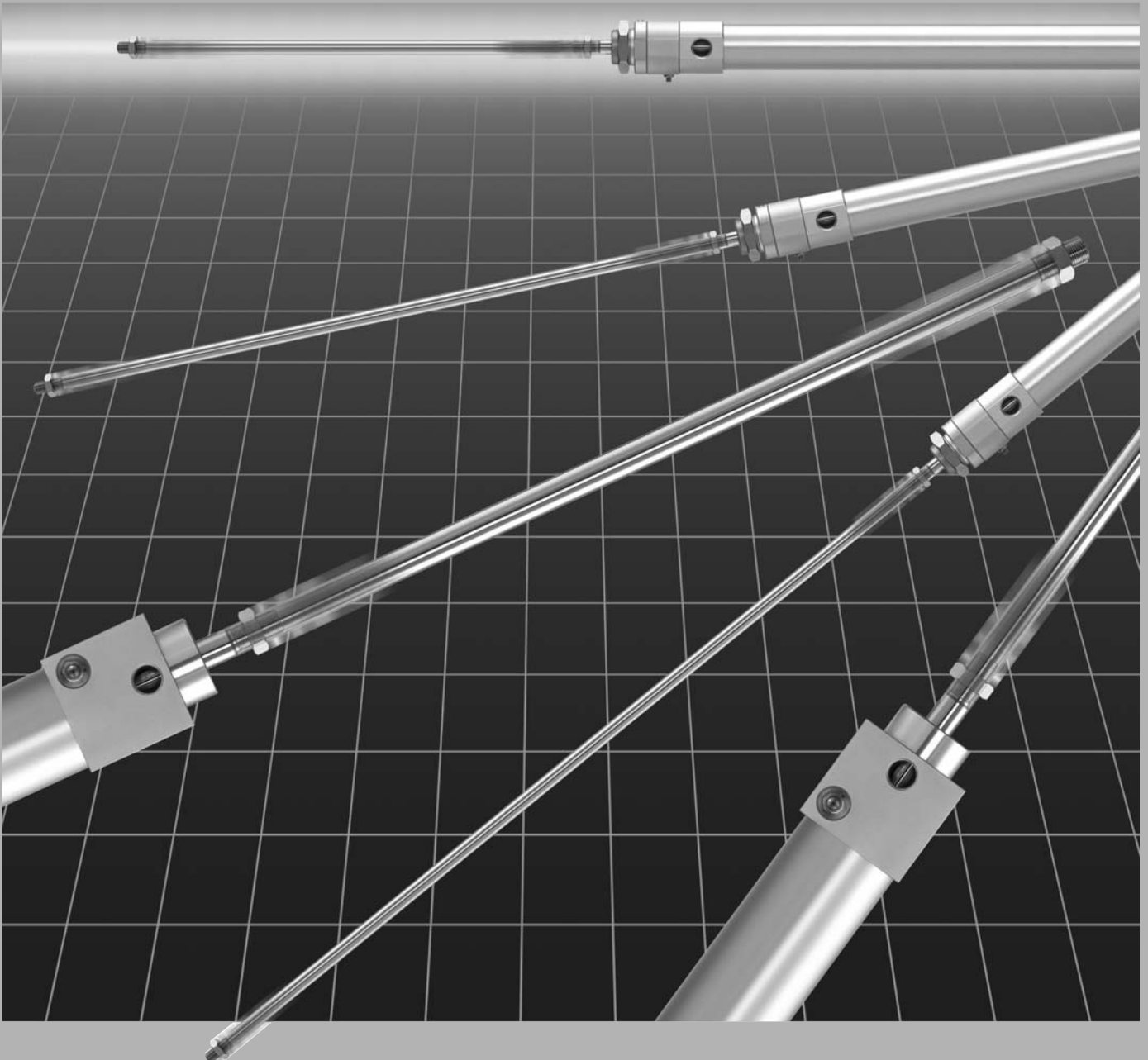

- REA
- REB
- REC
- C□Y
- C□X
- MQ
- RHC**
- RZQ

- D-□
- X□
- Individual
-X□

High power cylinder:

- Smooth cushioning for high speed operation (3000 mm/s) low/medium speed operation with heavy loads
- The capacity to absorb 10 to 20 times more energy than general purpose cylinders.

Supply/Exhaust port

The diameter of the port orifice has been enlarged to support high speed operation.

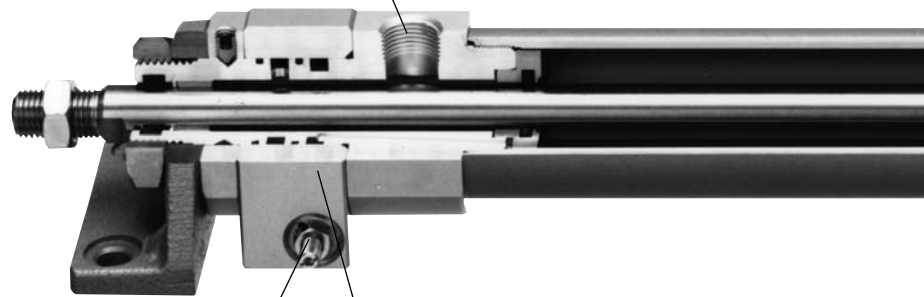
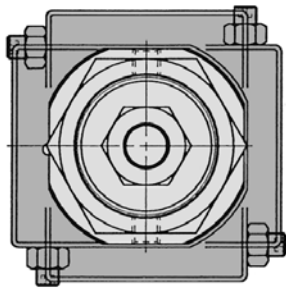

Relief valve adjusting screw

Relief valve body

The relief valve body rotates 360°, enabling relief adjustment from any direction.
($\phi 20$, $\phi 25$, $\phi 32$, $\phi 40$)

Mounting and Cushion Adjustment

Piping/mounting man-hours are the same as that of the general purpose cylinders.

Cushion adjustment (relief adjustment) man-hours are the same as the adjustment (cushion needle adjustment) for general purpose cylinders.

Cushion Capacity

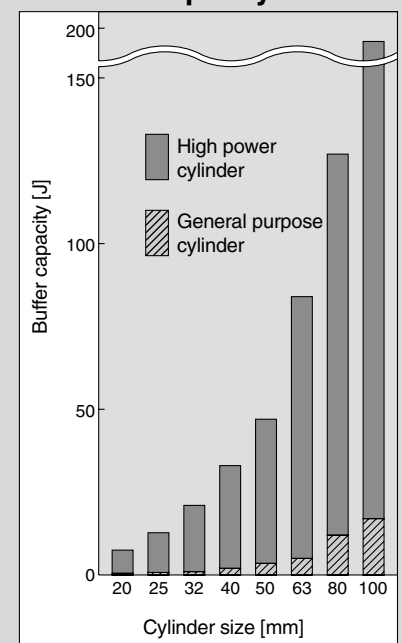

Quality of Cushioning (RHCF40-500, Load mass 5 kg, Supply pressure 0.5 MPa, Horizontal operation)

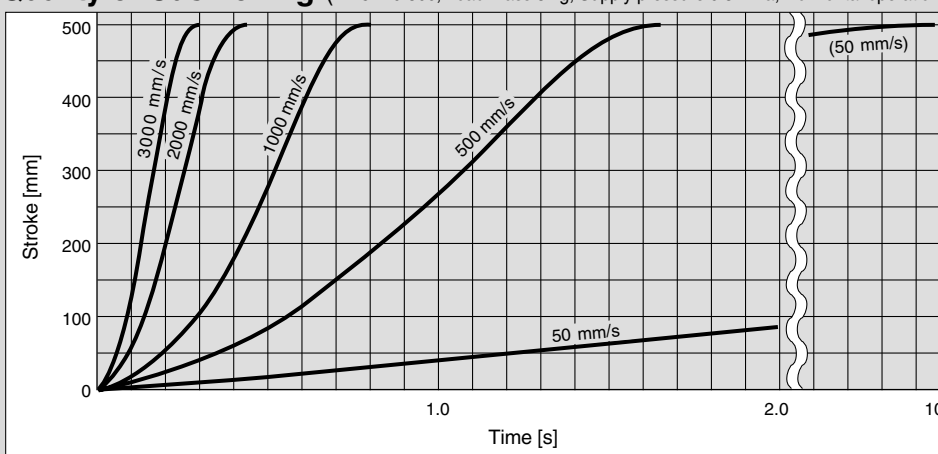

Series RHC

mm/s) with light loads and



Cushion ring

The long cushion ring can absorb larger energy (in terms of speed and mass).

Cushion seal

Strong seals are used for improved high speed durability and cushioning performance.



Relief valve

The relief valve is used as a cushion valve and it provides better cushioning performance than a needle throttle of a general purpose cylinder.

Application Examples

Opening/closing doors
(2000 mm/s,
several tens kg)

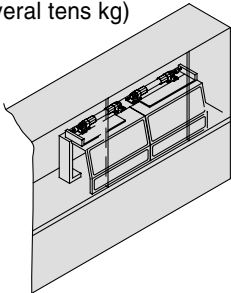

High speed Z-axis
(Up to 3000 mm/s, several kg)

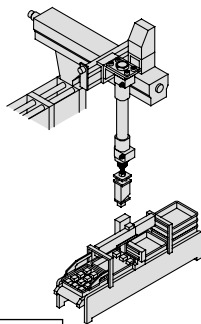

Transfer equipment
40 kg, 1000 mm/s (For ø32)

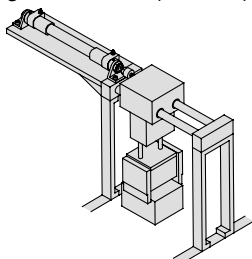

Working Principle

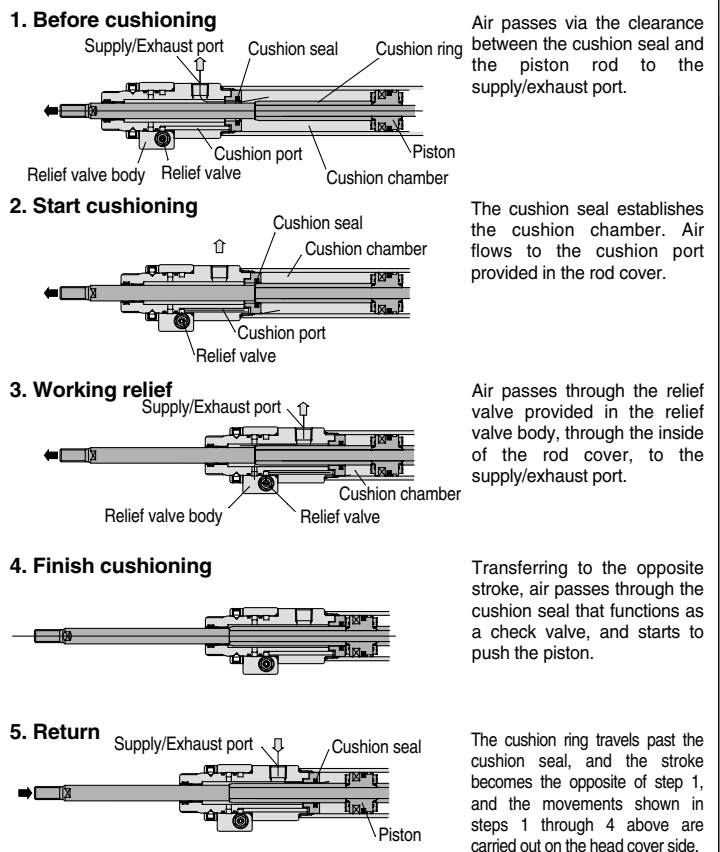

REA

REB

REC

C□Y

C□X

MQ

RHC

RZQ

D-□

-X□

Individual
-X□

Series RHC Model Selection

Model Selection Example of High Power Cylinder

Selection Example 1. Horizontal Drive

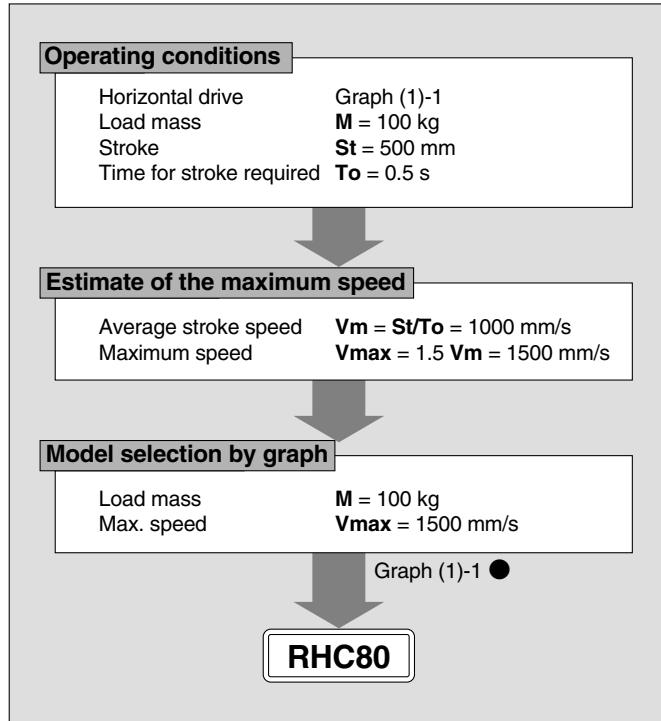

Graph (1)-1 Horizontal Drive Supply Pressure 0.5 MPa

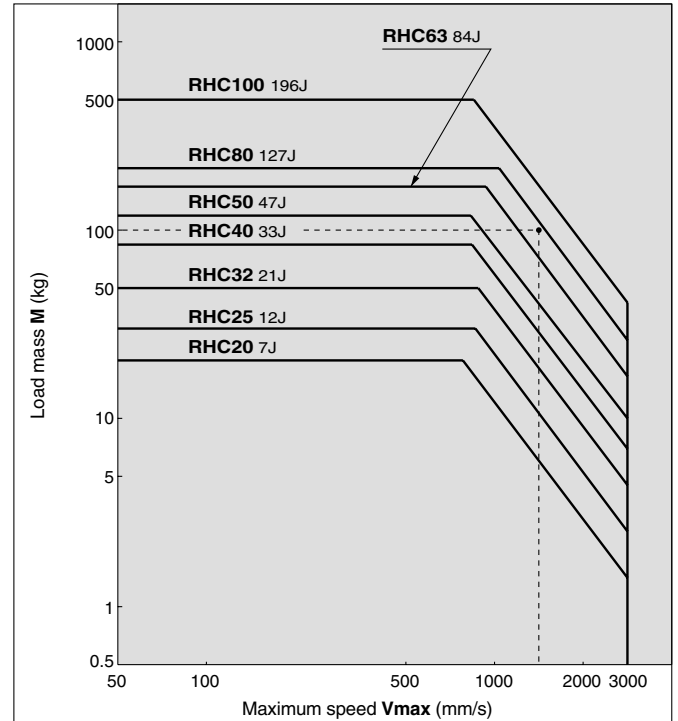

Selection Example 2. Vertical Drive

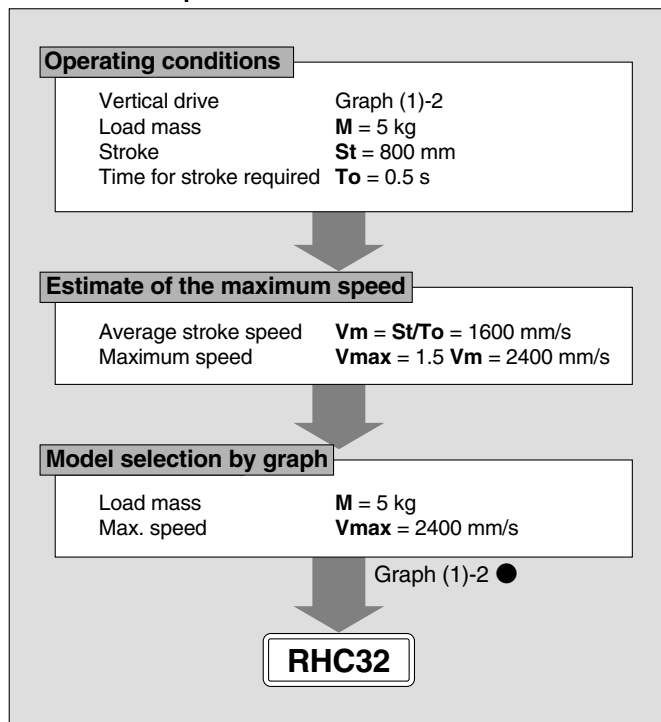

Graph (1)-2 Vertical Drive Supply Pressure 0.5 MPa

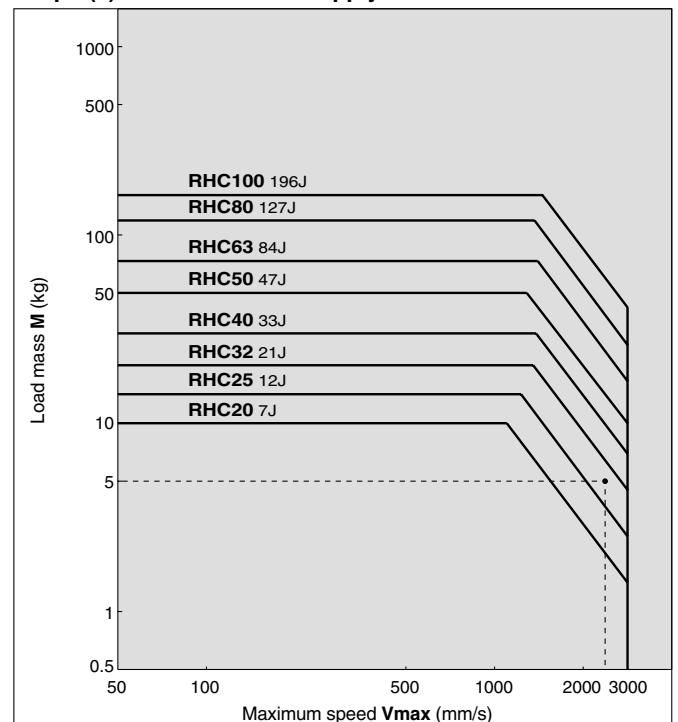

Maximum Energy Absorption

Bore size (mm)	20	25	32	40	50	63	80	100
Maximum energy absorption (J)	7	12	21	33	47	84	127	196

High Power Cylinder Series RHC System Selection

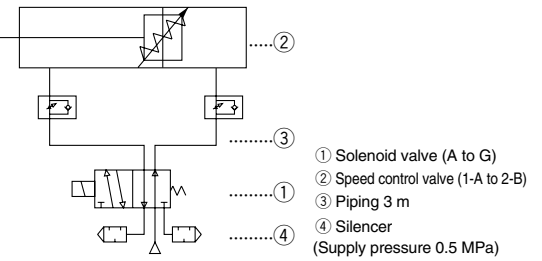

System Selection

Apply η (cylinder load ratio) and V_{max} (max. speed) and determine effective sectional area "So".

Refer to "System Selection" table, and the appropriate solenoid valve, speed control valve and bore size may be selected.

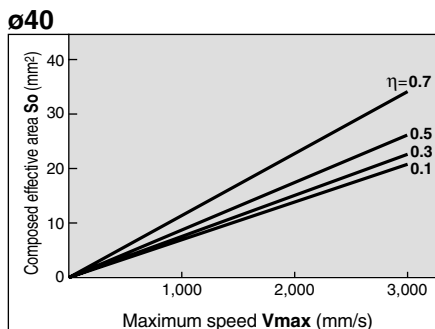
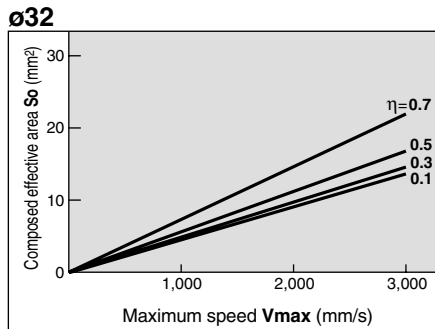
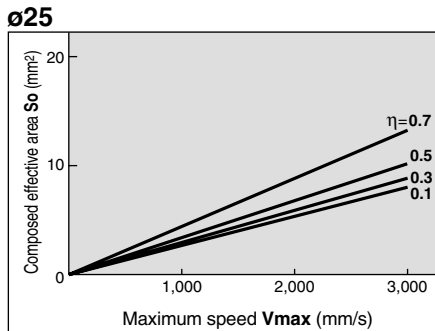
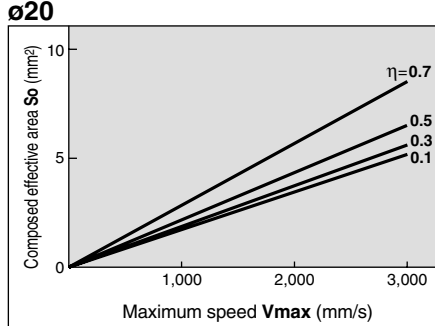

η : Cylinder load ratio
 V_{max} : Maximum speed (Refer to page 1198.)

Bore size (mm)	Maximum speed (mm/s)	Composed effective area (mm ²)	Solenoid valve (): Effective area [mm ²]					Speed controller		Tubing O.D. (mm) Steel piping size	
			A	B	C	D	E	With One-touch fittings	Elbow type		
			3.6 to 6.3	9.0 to 14.4	16.2 to 21.6	36 to 45	64.8 to 67				
			Metal seal								
20	500	1.5	VQ1000 (3.6)	VQ2000 (14.4)	—	VQ4000 (36.0)	—	1-A	Elbow type	ø6 1/8, 1/4	
			VQ1000 (5.4)	—	VQ2000 (16.2)	VQ4000 (39.6)	—				
			SY3000 (5.4)	SY5000 (12.6)	SY7000 (21.6)	—	—				
			SX3000 (5.4)	SX5000 (12.6)	SX7000 (21.6)	—	—				
			SYJ5000 (4.5)	SYJ7000 (12.6)	—	—	—				
			VQZ1000 (3.6)	VQZ2000 (12.6)	VQZ3000 (16.2)	—	—				
	1000	3	3	—	—	VFR2000 (16.2)	VFR3000 (41.4)	VFR4000 (67.0)	1-C	AS3001F (6.5)	ø6 1/4, 3/8
				—	VFS1000 (9.0)	VFS2000 (18.0)	VFS3000 (36.0)	VFS4000 (64.5)			
				—	—	—	—	—			
				—	—	—	—	—			
				—	—	—	—	—			
				—	—	—	—	—			
25	500	2.5	—	—	—	—	—	1-A	AS22□1F (3.5)	ø6 1/4, 3/8	
			—	—	—	—	—				
			—	—	—	—	—				
			—	—	—	—	—				
			—	—	—	—	—				
			—	—	—	—	—				
1000	3	3	—	—	—	—	—	1-B	AS23□1F (3.5)	ø6 1/4, 3/8	
			—	—	—	—	—				
			—	—	—	—	—				
			—	—	—	—	—				
			—	—	—	—	—				
			—	—	—	—	—				
25	1000	3	—	—	—	—	—	1-C	AS2051F (4.5)	ø6 1/4, 3/8	
			—	—	—	—	—				
			—	—	—	—	—				
			—	—	—	—	—				
			—	—	—	—	—				
			—	—	—	—	—				
32	500	4	—	—	—	—	—	2-A	AS22□0 (2.9)	ø8 1/4, 3/8	
			—	—	—	—	—				
			—	—	—	—	—				
			—	—	—	—	—				
			—	—	—	—	—				
			—	—	—	—	—				
32	1000	8	—	—	—	—	—	2-B	AS2000 (3.8)	ø8 1/4, 3/8	
			—	—	—	—	—				
			—	—	—	—	—				
			—	—	—	—	—				
			—	—	—	—	—				
			—	—	—	—	—				
40	500	6	—	—	—	—	—	1-C	AS3001F (10)	ø10 1/4, 3/8	
			—	—	—	—	—				
			—	—	—	—	—				
			—	—	—	—	—				
			—	—	—	—	—				
			—	—	—	—	—				
40	1000	12	—	—	—	—	—	2-B	AS4000 (25.5)	ø10 1/4, 3/8	
			—	—	—	—	—				
			—	—	—	—	—				
			—	—	—	—	—				
			—	—	—	—	—				
			—	—	—	—	—				
40	1500	18	—	—	—	—	—	1-C	AS4001F (16)	ø10 1/4, 3/8	
			—	—	—	—	—				
			—	—	—	—	—				
			—	—	—	—	—				
			—	—	—	—	—				
			—	—	—	—	—				
40	2000	24	—	—	—	—	—	2-A	AS32□0 (13)	ø10 1/4, 3/8	
			—	—	—	—	—				
			—	—	—	—	—				
			—	—	—	—	—				
			—	—	—	—	—				
			—	—	—	—	—				
40	2500	30	—	—	—	—	—	2-B	AS4000 (25.5)	ø10 1/4, 3/8	
			—	—	—	—	—				
			—	—	—	—	—				
			—	—	—	—	—				
			—	—	—	—	—				
			—	—	—	—	—				
40	3000	36	—	—	—	—	—	2-B	AS5000 (74)	ø10 1/4, 3/8	
			—	—	—	—	—				
			—	—	—	—	—				
			—	—	—	—	—				
			—	—	—	—	—				
			—	—	—	—	—				

Note) Refer to page 1202 for maximum absorbed energy since cushioning ability may in some cases exceed the allowable cushioning ability if the cylinder is used under high speeds and large loads.

REA

REB

REC

C□Y

C□X

MQ

RHC

RZQ

D-□

-X□

Individual
-X□

Series RHC

Apply η (cylinder load ratio) and V_{max} (max. speed) and determine effective sectional area "So".

Refer to "System Selection" table, and the appropriate solenoid valve, speed control valve and bore size may be selected.

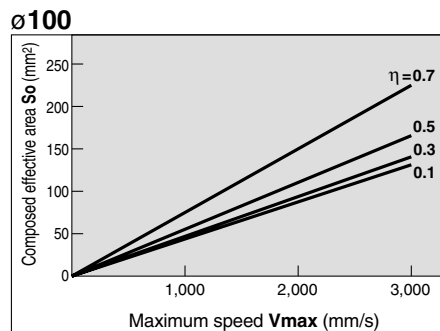
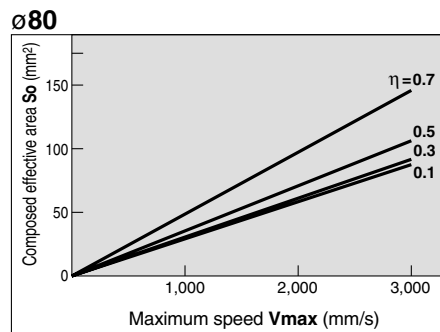
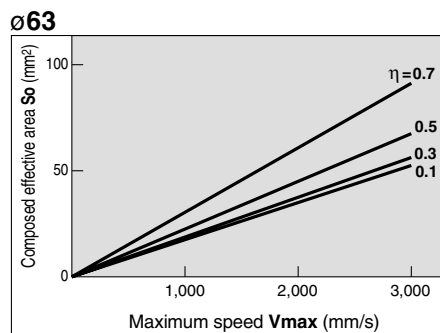
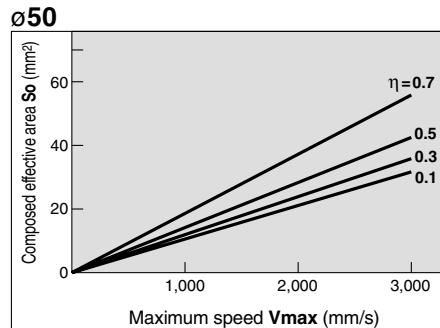

η : Cylinder load ratio

V_{max} : Maximum speed (Refer to page 1198.)

System Selection

Bore size (mm)	Maximum speed (mm/s)	Composed effective area (mm ²)	Solenoid valve (): Effective area [mm ²]					Speed controller			Tubing I.D. (mm) Steel piping size											
			: Metal seal					1-A Elbow type	1-B Universal type	1-C In-line type												
			C	D	E	F	G															
50	500	9.5	16.2 to 21.6	36 to 45	64.8 to 67	102.6 to 120	180 to 300	1-A AS42□1F (24)	2-B AS43□1F (24)	1-C AS4001F (16)	2-A AS4200 (26)	2-B AS420 (102)	ø8, ø10 1/4									
			—	VQ4000 (36.0)	—	—	—							—								
	1000	19	VQ2000 (16.2)	VQ4000 (39.6)	—	—	—	1-A AS42□1F (26)	2-B AS43□1F (24)	2-A AS4200 (26)	2-B AS420 (102)	3/8, ø16 1/4, 3/8										
			SX7000 (21.6)	—	—	—	—															
			—	—	—	—	—															
			VQZ3000 (16.2)	—	—	—	—															
			VQZ3000 (21.6)	—	—	—	—															
			VFR2000 (16.2)	VFR3000 (41.4)	VFR4000 (67.0)	VFR5000 (102.6)	VFR6000 (191)															
			VFS2000 (18.0)	VFS3000 (36.0)	VFS4000 (64.5)	VFS5000 (12.6)	VFS6000 (180)															
			—	—	—	VP□50 (120)	VP□70 (300)															
63	500	15	—	—	—	—	—	1-A AS42□1F (24)	2-B AS43□1F (24)	1-C AS4001F (16)	2-A AS4200 (26)	2-B AS420 (102)	ø10, ø12, ø16 1/4, 3/8									
			—	—	—	—	—															
	1000	30	1500	45	—	—	—	1-A AS4200 (123)	2-B AS420 (102)	2-A AS420 (102)	2-B AS420 (102)	3/8, ø16 1/2, ø16										
			2000	60	—	—	—															
			2500	75	—	—	—															
			3000	89.5	—	—	—															
			80	500	24.5	—	—							—	—	—	1-A AS4200 (26)	2-B AS420 (102)	1-C AS4001F (16)	2-A AS4200 (26)	2-B AS420 (102)	ø16 3/8, 1/2
						—	—							—	—	—						
				1000	48.5	1500	72.5							—	—	—	1-A AS500 (123)	2-B AS420 (102)	2-A AS420 (102)	2-B AS420 (102)	3/8, ø16 1/2, ø16	
						2000	96.5							—	—	—						
2500	120.5	—				—	—															
3000	106	—				—	—															
100	500	38				—	—	—	—	—	1-A AS420 (102)	2-B AS420 (102)	1-C AS4001F (16)	2-A AS4200 (26)	2-B AS420 (102)	3/4, ø16 1/2, ø16						
						—	—	—	—	—												
	1000	75.5				1500	113	—	—	—	1-A AS600 (258)	2-B AS420 (102)	2-A AS420 (102)	2-B AS420 (102)	3/4, ø16 1/2, ø16							
						2000	110.5	—	—	—												
			2500	138	—	—	—															
			3000	88.5	—	—	—															

Note) Refer to page 1202 for the maximum absorbed energy since cushioning ability may in some cases exceed the allowable cushioning ability if the cylinder is used under high speeds and large loads.

High Power Cylinder Series RHC

∅20, ∅25, ∅32, ∅40, ∅50, ∅63, ∅80, ∅100

How to Order

High Power Cylinder RHC B 20 - - M9BW -

High power cylinder

Mounting style

B	Basic style
L	Axial foot style
F	Rod side flange style
G	Head side flange style

Bore size

20	20mm
25	25mm
32	32mm
40	40mm
50	50mm
63	63mm
80	80mm
100	100mm

Port type

Nil	Rc
TN	NPT

Auto switch

Nil	Without auto switch (Built-in magnet)
-----	---------------------------------------

Number of auto switches

Nil	2 pcs.
S	1 pc.
n	"n" pcs.

Made to Order
Refer to page 1202 for details.

Cylinder stroke (mm)
* Refer to page 1202 for standard strokes.

* For the applicable auto switch model, refer to the table below.

Applicable Auto Switch/Refer to pages 1719 to 1827 for further information on auto switches.

Type	Special function	Electrical entry	Indicator light	Wiring (Output)	Load voltage		Auto switch model		Lead wire length (m)					Pre-wired connector	Applicable load			
					DC	AC	Applicable bore size (mm)		0.5 (Nil)	1 (M)	3 (L)	5 (Z)	None (N)					
							∅20 to ∅63	∅80, ∅100										
Solid state switch	—	Grommet	Yes	3-wire (NPN)	5V, 12V	—	M9N	—	●	●	●	○	—	○	IC circuit			
				3-wire (PNP)			M9P	—	●	●	●	○	—	○				
		Connector		2-wire	12V	—	M9B	—	●	●	●	○	—	○		—		
				H7C	—	●	—	●	●	●	—	—						
	Diagnostic indication (2-color indication)	Grommet	Yes	3-wire (NPN)	24V	—	M9NW	—	●	●	●	○	—	○	IC circuit			
				3-wire (PNP)			M9PW	—	●	●	●	○	—	○				
				2-wire	12V	M9BW	—	●	●	●	○	—	○	—				
						H7BA	G5BA	—	—	●	○	—	○					
				Water resistant (2-color indication)	Grommet	Yes	4-wire (NPN)	5V, 12V	—	H7NF	G59F	●	—	●	○	—	○	IC circuit
										With diagnostic output (2-color indication)	—	—	—	—	—	—	—	—
Reed switch	—	Grommet	Yes	3-wire (NPN equivalent)	—	5V	A96	—	●	—	●	—	—	—	IC circuit	—		
				100V			A93	—	●	—	●	—	—	—	—			
				100 V or less	A90	—	●	—	●	—	—	—	—	IC circuit				
				100V, 200V	B54		●	—	●	●	—	—	—	—				
					B64		●	—	●	—	—	—	—					
				200 V or less	C73C		—	●	—	●	●	●	—	—				
		C80C			—	●	—	●	●	●	—							
		24 V or less		A33		—	—	—	—	—	●	—	—					
				A34		—	—	—	—	—	●	—						
		100V, 200V		A44		—	—	—	—	—	●	—	—					
				B59W		●	—	●	—	—	—	—						
		Diagnostic indication (2-color indication)		Grommet	Yes	2-wire	24V	12V	—		—	—	—	—	—		—	IC circuit
—			A33						—	—	—	—	—	—	PLC			
—		Terminal conduit	Yes	2-wire	24V	12V	—		—	—	—	—	—	—	—			
—							A34		—	—	—	—	—	—		—		
—		DIN terminal	Yes	2-wire	24V	12V	—		—	—	—	—	—	—	—			
—							A44		—	—	—	—	—	—		—		
—		Grommet	Yes	2-wire	24V	12V	—		—	—	—	—	—	—	—			
—							B59W		●	—	●	—	—	—		—		

* Lead wire length symbols: 0.5 m Nil (Example) M9NW
 1 m M (Example) M9NWM
 3 m L (Example) M9NWL
 5 m Z (Example) M9NWZ
 None N (Example) H7CN

* Solid state auto switches marked with "○" are produced upon receipt of order.
 * D-A9□V/M9□V/M9□WV/D-M9□A(V)L types cannot be mounted.
 * Do not indicate suffix "N" for no lead wire on D-A3□/A44/G39/K39 models.

* Since there are other applicable auto switches than listed, refer to page 1214 for details.
 * For details about auto switches with pre-wired connector, refer to pages 1784 and 1785.
 * D-A9□/M9□/M9□W auto switches are shipped together (not assembled). (Only auto switch mounting brackets are assembled before shipped).

Series RHC



JIS Symbol

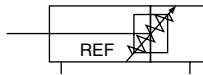

Made to Order
(Refer to page 1882 for details.)

Symbol	Specification
-XC6	Made of stainless steel

Specifications

Bore size (mm)	20	25	32	40	50	63	80	100
Fluid	Air							
Proof pressure	1.5 MPa							
Maximum operating pressure	1.0 MPa							
Minimum operating pressure	0.05 MPa							
Ambient and fluid temperature	-10 to 60°C (No freezing)							
Piston speed	50 to 3000 mm/s							
Cushion	Air cushion							
Maximum energy absorption (J)	7	12	21	33	47	84	127	196
Effective cushioning stroke (mm)	80	80	80	80	80	80	80	80
Lubrication	Not required (Non-lube)							
Stroke length tolerance	Up to 1000 st: ${}^{+1.4}_0$, 1001 to 1500 st: ${}^{+1.8}_0$							
Mounting	Basic style, Axial foot style, Rod/Head side flange style							

Stroke

Bore size (mm)	Minimum stroke (Recommended) ⁽¹⁾	Standard stroke ⁽²⁾	Max. stroke
20	250	up to 700	1500
25	250	up to 700	1500
32	250	up to 1000	1500
40	250	up to 1000	1500
50	250	up to 1200	1500
63	250	up to 1200	1500
80	250	up to 1400	1500
100	250	up to 1500	1500

Note 1) Strokes shorter than the recommended minimum stroke (1 to 249 st) can be manufactured, but cushion capability may not be satisfied since the effective cushion stroke for this cylinder is long.

Note 2) Stroke exceeding the standard stroke length is not subject to the guarantee.

Mounting Bracket Part No.

Mounting bracket	Qty.	Bore size (mm)								Description
		20	25	32	40	50	63	80	100	
Axial foot	Note) 2	RHC-L020	RHC-L025	RHC-L032	RHC-L040	RHC-L050	RHC-L063	RHC-L080	RHC-L100	ø20 to ø40 : Foot x 2, Mounting nut x 1 ø50 to ø100: Foot x 2, Bracket mounting bolt x 8, Spring washer x 8
Flange	1	RHC-F020	RHC-F025	RHC-F032	RHC-F040	RHC-F050	RHC-F063	RHC-F080	RHC-F100	ø20 to ø40 : Flange x 1 ø50 to ø100: Flange x 1, Bracket mounting bolt x 4, Spring washer x 4

Note) Order 2 foot brackets for a cylinder.

Theoretical Output



Bore size (mm)	Rod size (mm)	Operating direction	Piston area (mm ²)	Operating pressure (MPa)								
				0.2	0.3	0.4	0.5	0.6	0.7	0.8	0.9	1.0
20	10	OUT	314	63	94	126	157	188	220	251	283	314
		IN	236	47	71	94	118	142	165	189	212	236
25	12	OUT	491	98	147	196	246	295	344	393	442	491
		IN	378	76	113	151	189	227	265	302	340	378
32	12	OUT	804	161	241	322	402	482	563	643	724	804
		IN	691	138	207	276	346	415	484	553	622	691
40	16	OUT	1260	252	378	504	630	756	882	1010	1130	1260
		IN	1060	212	318	424	530	636	742	848	954	1060
50	20	OUT	1960	392	588	784	980	1180	1370	1570	1760	1960
		IN	1650	330	495	660	825	990	1160	1320	1490	1650
63	20	OUT	3120	624	936	1250	1560	1870	2180	2500	2810	3120
		IN	2800	560	840	1120	1400	1680	1960	2240	2520	2800
80	25	OUT	5030	1010	1510	2010	2520	3020	3520	4020	4530	5030
		IN	4540	908	1360	1820	2270	2720	3180	3630	4090	4540
100	30	OUT	7850	1570	2360	3140	3930	4710	5500	6280	7070	7850
		IN	7150	1430	2150	2860	3580	4290	5010	5720	6440	7150

Note) Theoretical output (N) = Pressure (MPa) x Piston area (mm²)

Mass (In the case of 500 stroke)

Bore size (mm)		20	25	32	40	50	63	80	100
Basic mass	Basic style	1.20	1.62	2.04	3.20	4.90	6.08	8.93	13.60
	Axial foot style	1.44	1.88	2.44	3.72	5.95	7.32	11.04	16.67
	Flange style	1.29	1.79	2.23	3.47	5.68	6.97	10.67	15.92
Additional mass per each 50 mm of stroke		0.06	0.08	0.09	0.15	0.22	0.25	0.35	0.51

Calculation: (Example) **RHCL32-600**

- Basic mass (500 st) 2.44 (kg) (Foot style ø32)
- Additional mass 0.09 (kg/50 st)
- Cylinder stroke 600 (st)

$$2.44 + 0.09 \times (600 - 500) / 50 = 2.62 \text{ kg}$$

Copper and Fluorine-free Air Cylinder

20-RHC —

↓ Copper and fluorine-free

The type which prevents copper based ions from generating by changing the copper based materials with electroless nickel plated treatment or non-copper materials in order to eliminate the effects by copper based ions or fluororesins over the color cathode ray tube.

Specifications

Action	Double acting, Single rod
Bore size	ø20, ø25, ø32, ø40, ø50, ø63, ø80, ø100
Max. operating pressure	1 MPa
Min. operating pressure	0.05 MPa
Cushion	Air cushion
Piping	Screw-in type
Piston speed	50 to 3000 mm/s
Mounting	Basic style, Axial foot style, Rod side flange style, Head side flange style

REA

REB

REC

C□Y

C□X

MQ

RHC

RZQ

D-□

-X□

Individual
-X□

Series RHC

Construction: $\varnothing 20$ to $\varnothing 40$

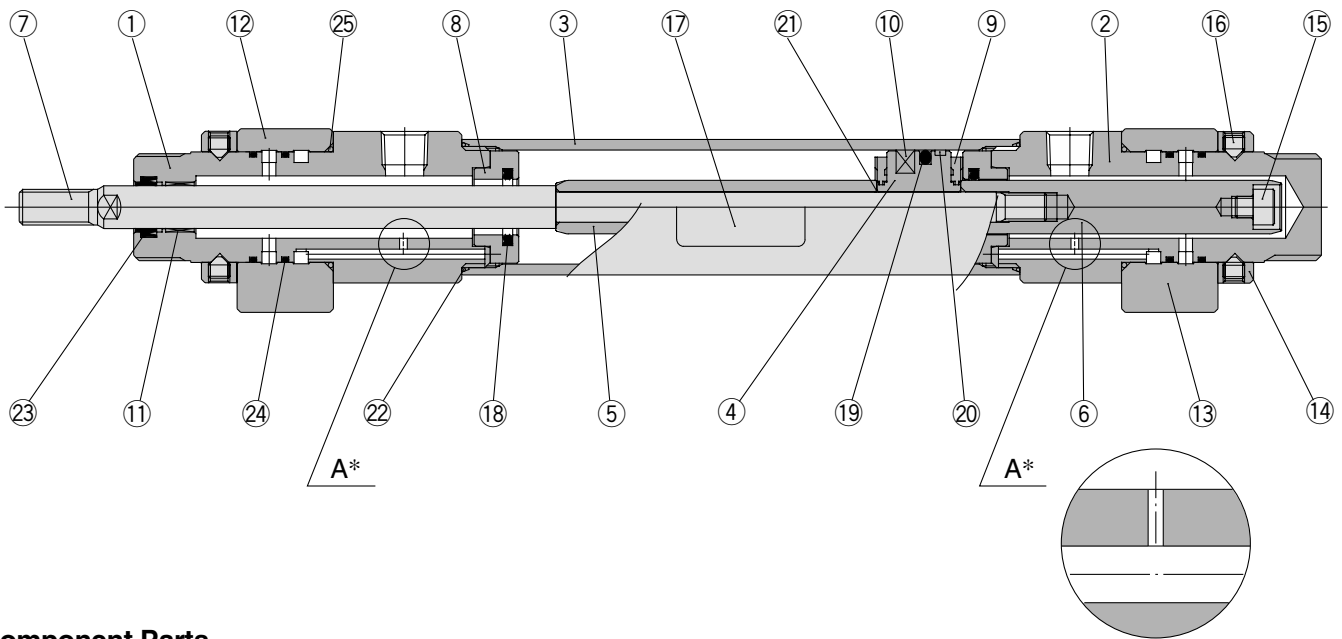

Component Parts

No.	Description	Material	Note
1	Rod cover	Aluminum alloy	Clear anodized
2	Head cover	Aluminum alloy	Clear anodized
3	Cylinder tube	Aluminum alloy	Hard anodized
4	Piston	Aluminum alloy	Chromated
5	Cushion ring A	Carbon steel	Hard chrome plated
6	Cushion ring B	Carbon steel	Hard chrome plated
7	Piston rod	Carbon steel *	Hard chrome plated
8	Cushion spacer	Stainless steel	
9	Bumper	Urethane	
10	Magnet	—	
11	Bushing	Copper oil-impregnated sintered alloy	
12	Relief valve assembly (Rod side)	—	
13	Relief valve assembly (Head side)	—	
14	Relief valve body holder	Aluminum alloy	Clear anodized
15	Hexagon socket head cap screw	Carbon steel	$\varnothing 20$: M5 x 0.8 x 6 $\varnothing 25, \varnothing 32$: M6 x 1 x 6 $\varnothing 40$: M8 x 1.25 x 8 Nickel plated
16	Hexagon socket head set screw	Carbon steel	$\varnothing 20, \varnothing 25$: M5 x 0.8 x 6 $\varnothing 32, \varnothing 40$: M6 x 1 x 8 Nickel plated
17	Plate	—	
18	Cushion seal	Special resin	
19	Piston seal	NBR	
20	Wear ring	Resin	
21	Piston gasket	NBR	
22	Cylinder tube gasket	NBR	
23	Rod seal	NBR	
24	O-ring	NBR	
25	O-ring	NBR	

* Stainless steel for $\varnothing 20$ and $\varnothing 25$

Enlarged view of "A"

Replacement Parts/Seal Kit

Bore size (mm)	Kit no.	Contents
20	RHC20-PS	Set of nos. left 18, 19, 20, 22, 23, 24, 25
25	RHC25-PS	
32	RHC32-PS	
40	RHC40-PS	

* Seal kit includes a grease pack (10 g).

Order with the following part number when only the grease pack is needed.

Grease pack part no.: GR-S-010 (10 g)

⚠ Caution

When disassembling cylinders with bore sizes of $\varnothing 20$ through $\varnothing 40$, grip the double flat part of either the rod cover or the head cover with a vise and loosen the other side with a wrench or an adjustable angle wrench, and then remove the cover. When re-tightening, tighten approximately 2 degrees more than the original position.

Construction: $\varnothing 50$ to $\varnothing 100$

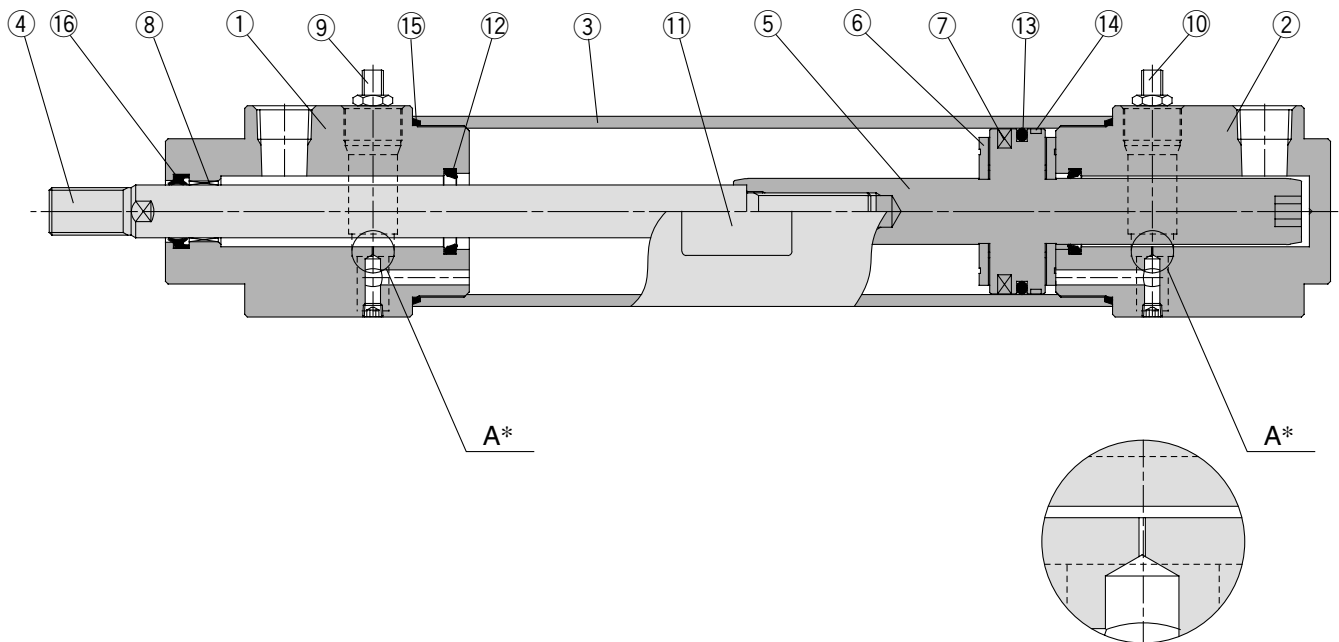

Enlarged view of "A"

Component Parts

No.	Description	Material	Note
1	Rod cover	Aluminum alloy	Clear anodized
2	Head cover	Aluminum alloy	Clear anodized
3	Cylinder tube	Aluminum alloy	Hard anodized
4	Piston rod	Carbon steel	Hard chromate plated
5	Piston	Aluminum alloy	Hard anodized
6	Bumper	Urethan	
7	Magnet	—	
8	Bushing	—	
9	Relief valve assembly L	—	
10	Relief valve assembly R	—	
11	Plate	—	
12	Cushion seal	Urethan	
13	Piston seal	NBR	
14	Wear ring	Resin	
15	Cylinder tube gasket	NBR	
16	Rod seal	NBR	

Caution

Cylinders with $\varnothing 50$ or larger bore sizes are tightened with a large tightening torque and cannot be disassembled. Contact SMC when disassembly is required.

REA

REB

REC

Y

X

MQ

RHC

RZQ

D-

-X

Individual
-X

Series RHC

Dimensions: Basic Style

ø20 to ø40

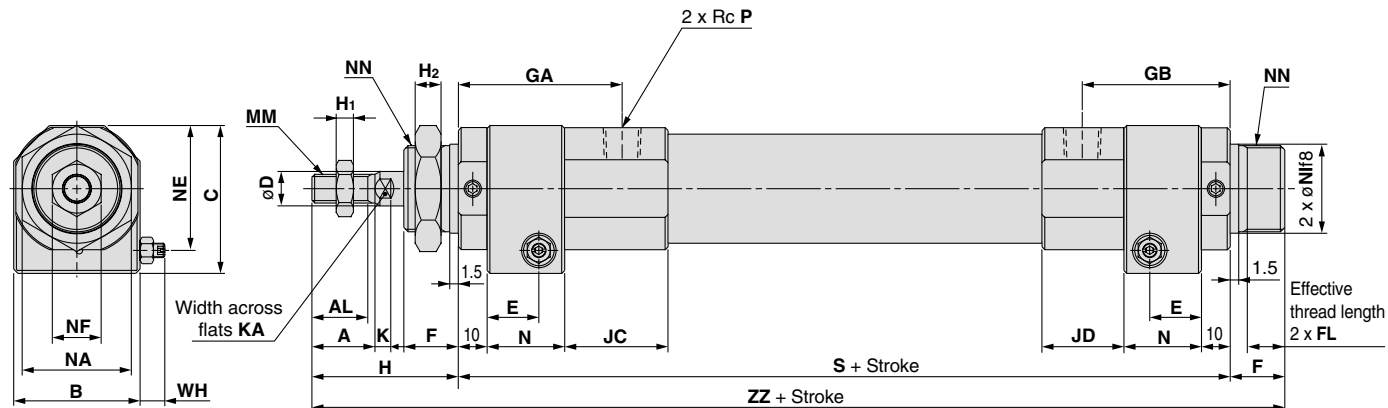

(mm)

Bore size (mm)	A	AL	B	C	D	E	F	FL	GA	GB	H	H1	H2
20	18	15.5	32	40.5	10	14.5	16	11.5	53.5	47.5	44	5	8
25	22	19.5	36	45.5	12	18	16	11.5	56.5	49.5	48	6	8
32	22	19.5	44	51.5	12	18	19	14.5	55	51.5	51	6	9
40	24	21	53	61.5	16	20.5	21	16.5	56	51.5	54.5	8	11

Bore size (mm)	JC	JD	K	KA	MM	N	NE	NA	NF	NI	NN	P	S	WH	ZZ
20	43	30.5	5	8	M8 x 1.25	22	33.5	26	13	23 ^{-0.020} _{-0.053}	M22 x 1.5	1/4	192	5.8 to 8.8	252
25	39	25.5	5.5	10	M10 x 1.25	27	37	32	17	25 ^{-0.020} _{-0.053}	M24 x 1.5	1/4	193		257
32	36	28.5	5.5	10	M10 x 1.25	27	43.5	38	17	31 ^{-0.025} _{-0.064}	M30 x 1.5	3/8	195		265
40	32	23	7.5	14	M14 x 1.5	30	52.5	41	22	34 ^{-0.025} _{-0.064}	M33 x 2.0	3/8	201.5	6.8 to 11.3	277

ø50 to ø100

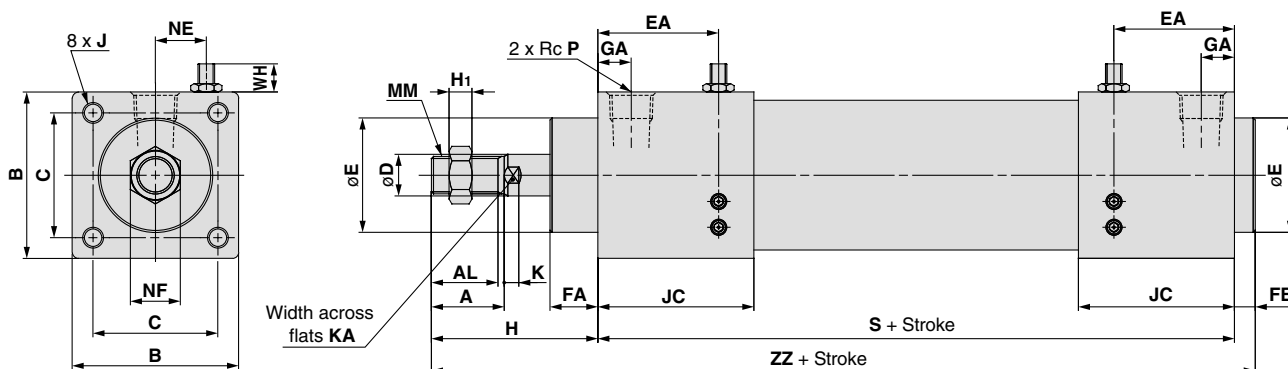

(mm)

Bore size (mm)	A	AL	B	C	D	E	EA	FA	FB	GA	H
50	35	32	70	53	20	50 ⁰ _{-0.062}	62	23	10	16	80
63	35	32	80	60	20	55 ⁰ _{-0.074}	58	23	10	16	80
80	40	37	95	75	25	65 ⁰ _{-0.074}	61	23	10	20	90
100	40	37	116	90	30	80 ⁰ _{-0.074}	63	25	10	20	95

Bore size (mm)	H1	J	JC	K	KA	MM	NE	NF	P	S	WH	ZZ
50	11	M10 x 1.5 thread depth 20	75	7	18	M18 x 1.5	25	27	1/2	215	6.8 to 11.3	305
63	11	M10 x 1.5 thread depth 20	75	7	18	M18 x 1.5	24.5	27	1/2	215		305
80	13	M12 x 1.75 thread depth 25	78	10	22	M22 x 1.5	30.5	32	3/4	228		328
100	16	M12 x 1.75 thread depth 25	80	10	26	M26 x 1.5	34	41	3/4	236	8.5 to 13.5	341

Dimensions: Axial Foot Style

ø20 to ø40

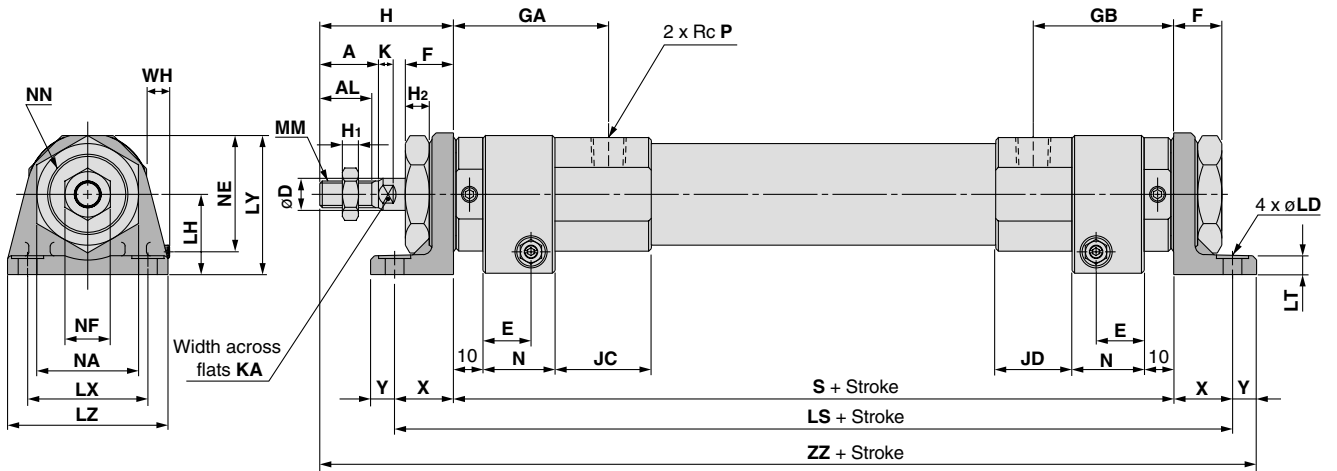

(mm)

Bore size (mm)	A	AL	D	E	F	FL	GA	GB	H	H ₁	H ₂	JC	JD	K	KA	LD	LH
20	18	15.5	10	14.5	16	11.5	53.5	47.5	44	5	8	43	30.5	5	8	7	25
25	22	19.5	12	18	16	11.5	56.5	49.5	48	6	8	39	25.5	5.5	10	7	28
32	22	19.5	12	18	19	14.5	55	51.5	51	6	9	36	28.5	5.5	10	7	30
40	24	21	16	20.5	21	16.5	56	51.5	54.5	8	11	32	23	7.5	14	9	35

Bore size (mm)	LS	LT	LX	LY	LZ	MM	N	NA	NE	NF	NN	P	S	WH	X	Y	ZZ
20	232	6.5	40	41	55	M8 x 1.25	22	26	33.5	13	M22 x 1.5	1/4	192	5.8 to 8.8	20	9	265
25	233	6.5	40	46.5	55	M10 x 1.25	27	32	37	17	M24 x 1.5	1/4	193		20	9	270
32	241	7	45	53	60	M10 x 1.25	27	38	43.5	17	M30 x 1.5	3/8	195		23	9	278
40	251.5	7	55	62	75	M14 x 1.5	30	41	52.5	22	M33 x 2.0	3/8	201.5	6.8 to 11.3	25	11	292

ø50 to ø100

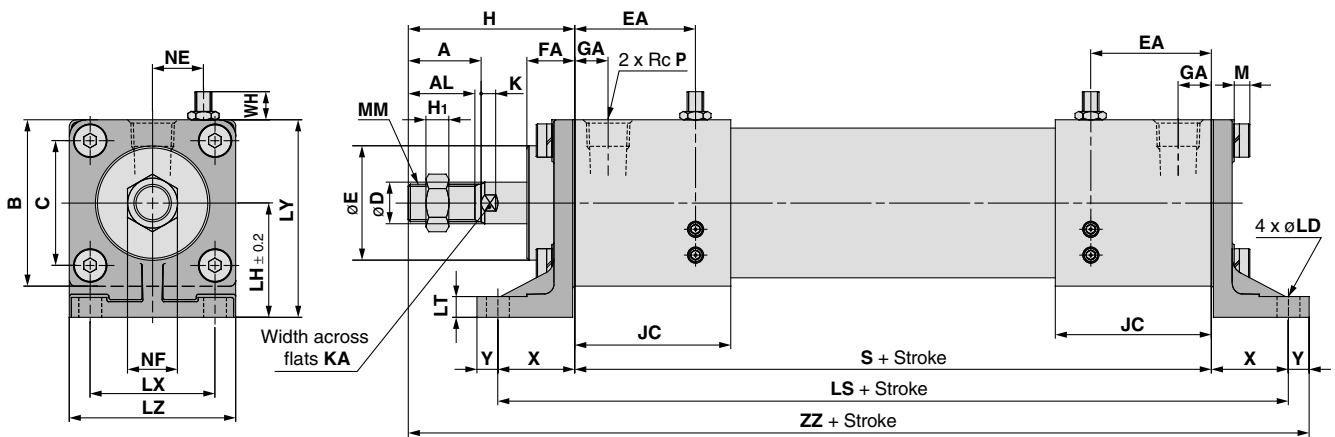

(mm)

Bore size (mm)	A	AL	B	C	D	E	EA	FA	GA	H	H ₁	JC	K	KA	LD
50	35	32	70	53	20	50 ^{-0.062}	62	23	16	80	11	75	7	18	11
63	35	32	80	60	20	55 ^{-0.074}	58	23	16	80	11	75	7	18	11
80	40	37	95	75	25	65 ^{-0.074}	61	23	20	90	13	78	10	22	13
100	40	37	116	90	30	80 ^{-0.074}	63	25	20	95	16	80	10	26	13

Bore size (mm)	LH	LS	LT	LY	LX	LZ	M	MM	NE	NF	P	S	WH	X	Y	ZZ
50	52	275	10	88.5	53	73	7.5	M18 x 1.5	25	27	1/2	215	6.8 to 11.3	30	10	335
63	55	289	10	95	60	80	7.5	M18 x 1.5	24.5	27	1/2	215		37	10	342
80	65	308	12	115	75	100	10	M22 x 1.5	30.5	32	3/4	228		40	13	371
100	80	330	14	139	90	118	10	M26 x 1.5	34	41	3/4	236		47	13	391

REA

REB

REC

C□Y

C□X

MQ

RHC

RZQ

D-□

-X□

Individual

-X□

Series RHC

Dimensions: Rod Side Flange Style

ø20 to ø40

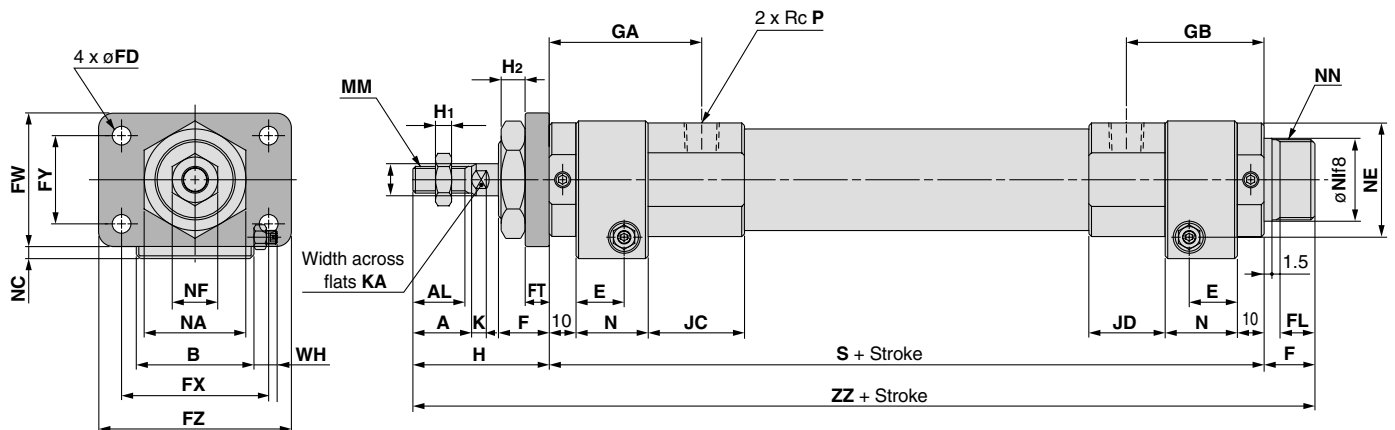

(mm)

Bore size (mm)	A	AL	B	D	E	F	FL	FD	FT	FX	FY	FW	FZ	GA	GB	H ₁	H ₂
20	18	15.5	32	10	14.5	16	11.5	7	6	51	21	38	68	53.5	47.5	5	8
25	22	19.5	36	12	18	16	11.5	7	9	53	27	44	70	56.5	49.5	6	8
32	22	19.5	44	12	18	19	14.5	7	9	55	33	50	72	55	51.5	6	9
40	24	21	53	16	20.5	21	16.5	9	9	66	36	60	84	56	51.5	8	11

Bore size (mm)	H	JC	JD	K	KA	MM	N	NA	NC	NE	NF	NI	NN	P	S	WH	ZZ
20	44	43	30.5	5	8	M8 x 1.25	22	26	5.5	33.5	13	23 ^{-0.020} _{-0.053}	M22 x 1.5	1/4	192	5.8 to 8.8	252
25	48	39	25.5	5.5	10	M10 x 1.25	27	32	5.5	37	17	25 ^{-0.020} _{-0.053}	M24 x 1.5	1/4	193		257
32	51	36	28.5	5.5	10	M10 x 1.25	27	38	4.5	43.5	17	31 ^{-0.025} _{-0.064}	M30 x 1.5	3/8	195	265	
40	54.5	32	23	7.5	14	M14 x 1.5	30	41	4.5	52.5	22	34 ^{-0.025} _{-0.064}	M33 x 2.0	3/8	201.5	6.8 to 11.3	277

ø50 to ø100

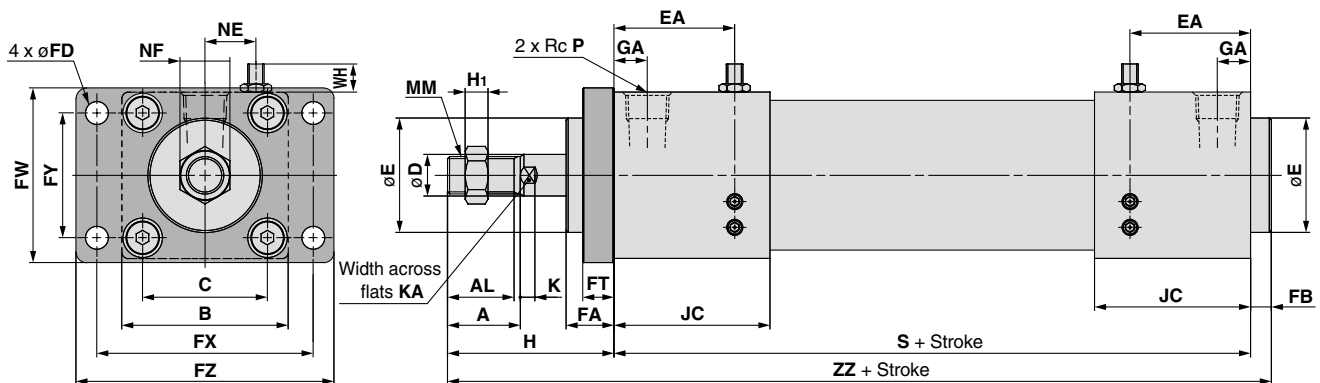

(mm)

Bore size (mm)	A	AL	B	C	D	E	EA	FA	FB	FD	FT	FW	FX
50	35	32	70	53	20	50 ⁰ _{-0.062}	62	23	10	11	15	78	96
63	35	32	80	60	20	55 ⁰ _{-0.074}	58	23	10	11	15	84	104
80	40	37	95	75	25	65 ⁰ _{-0.074}	61	23	10	13	18	106	130
100	40	37	116	90	30	80 ⁰ _{-0.074}	63	25	10	13	20	120	145

Bore size (mm)	FY	FZ	GA	H	H ₁	JC	K	KA	MM	NE	NF	P	S	WH	ZZ
50	53	116	16	80	11	75	7	18	M18 x 1.5	25	27	1/2	215	6.8 to 11.3	305
63	60	124	16	80	11	75	7	18	M18 x 1.5	24.5	27	1/2	215		305
80	75	155	20	90	13	78	10	22	M22 x 1.5	30.5	32	3/4	228	8.5 to 13.5	328
100	90	172	20	95	16	80	10	26	M26 x 1.5	34	41	3/4	236		341

Dimensions: Head Side Flange Style

ø20 to ø40

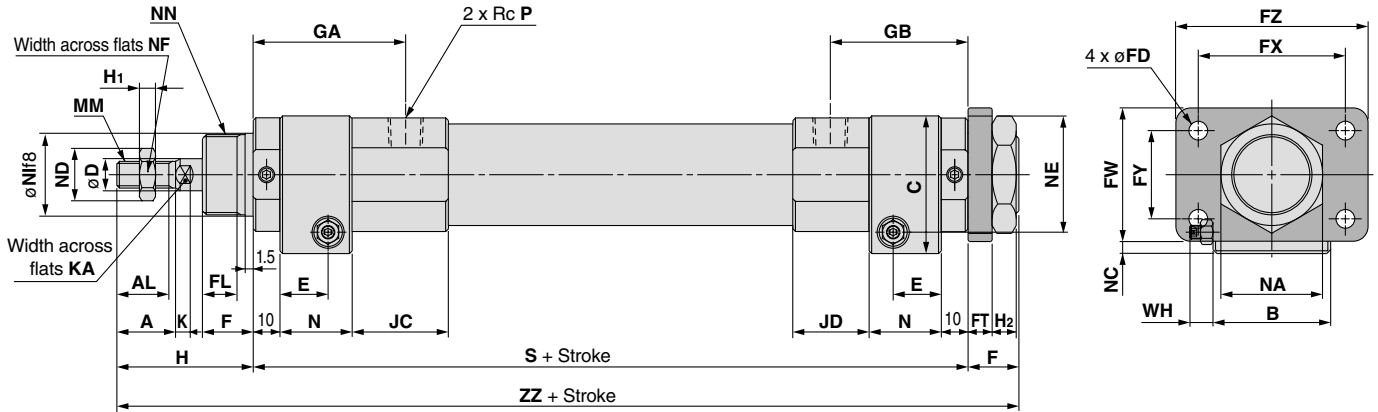

(mm)

Bore size (mm)	A	AL	B	C	D	E	F	FL	FD	FT	FX	FY	FW	FZ	GA	GB	H ₁	H ₂
20	18	15.5	32	40.5	10	14.5	16	11.5	7	6	51	21	38	68	53.5	47.5	5	8
25	22	19.5	36	45.5	12	18	16	11.5	7	9	53	27	44	70	56.5	49.5	6	8
32	22	19.5	44	51.5	12	18	19	14.5	7	9	55	33	50	72	55	51.5	6	9
40	24	21	53	61.5	16	20.5	21	16.5	9	9	66	36	60	84	56	51.5	8	11

Bore size (mm)	H	JC	JD	K	KA	MM	N	NA	NB	NC	NE	NF	NI	NN	P	S	WH	ZZ
20	44	43	30.5	5	8	M8 x 1.25	22	26	30	5.5	33.5	13	23 ^{-0.020} _{-0.053}	M22 x 1.5	1/4	192	5.8 to 8.8	252
25	48	39	25.5	5.5	10	M10 x 1.25	27	32	36.9	5.5	37	17	25 ^{-0.020} _{-0.053}	M24 x 1.5	1/4	193		257
32	51	36	28.5	5.5	10	M10 x 1.25	27	38	43.9	4.5	43.5	17	31 ^{-0.025} _{-0.064}	M30 x 1.5	3/8	195		265
40	54.5	32	23	7.5	14	M14 x 1.5	30	41	47.3	4.5	52.5	22	34 ^{-0.025} _{-0.064}	M33 x 2.0	3/8	201.5		6.8 to 11.3

ø50 to ø100

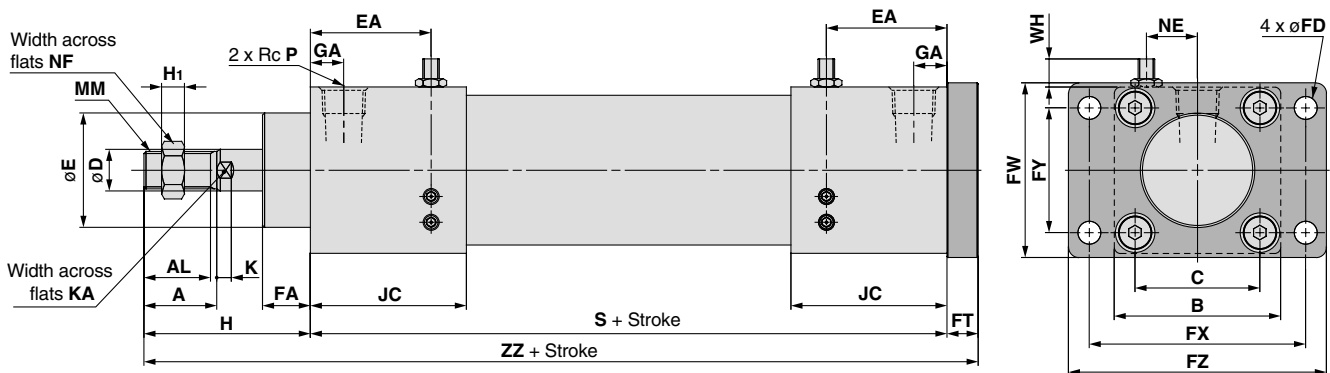

(mm)

Bore size (mm)	A	AL	B	C	D	E	EA	FA	FD	FT	FW	FX	FY
50	35	32	70	53	20	50 ⁰ _{-0.062}	62	23	11	15	78	96	53
63	35	32	80	60	20	55 ⁰ _{-0.074}	58	23	11	15	84	104	60
80	40	37	95	75	25	65 ⁰ _{-0.074}	61	23	13	18	106	130	75
100	40	37	116	90	30	80 ⁰ _{-0.074}	63	25	13	20	120	145	90

Bore size (mm)	FZ	GA	H	H ₁	JC	K	KA	MM	NE	NF	P	S	WH	ZZ
50	116	16	80	11	75	7	18	M18 x 1.5	25	27	1/2	215	6.8 to 11.3	310
63	124	16	80	11	75	7	18	M18 x 1.5	24.5	27	1/2	215		310
80	155	20	90	13	78	10	22	M22 x 1.5	30.5	32	3/4	228	8.5 to 13.5	336
100	172	20	95	16	80	10	26	M26 x 1.5	34	41	3/4	236		351

REA

REB

REC

C□Y

C□X

MQ

RHC

RZQ

D-□

-X□

Individual

-X□

Series RHC

Accessory

Mounting Nut

(mm)

Material: Carbon steel

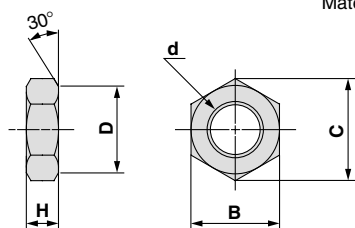

Part no.	Applicable bore size (mm)	B	C	D	d	H
SOR-20	20	26	30	26	M22 x 1.5	8
SOR-25	25	32	36.9	32	M24 x 1.5	8
SOR-32	32	38	43.9	38	M30 x 1.5	9
SOR-40	40	41	47.3	41	M33 x 2.0	11

Rod End Nut

(mm)

Material: Carbon steel

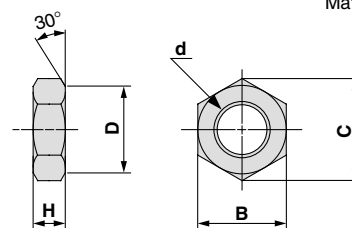

Part no.	Applicable bore size (mm)	B	C	D	d	H
NT-02	20	13	15	12.5	M8 x 1.25	5
NT-03	25/32	17	19.6	16.5	M10 x 1.25	6
NT-04	40	22	25.4	21.0	M14 x 1.5	8
NT-05	50/63	27	31	26	M18 x 1.5	11
NT-08	80	32	37	31	M22 x 1.5	13
NT-10	100	41	47.3	39	M26 x 1.5	16

Minimum Stroke for Auto Switch Mounting

Auto switch model	No. of auto switches mounted				
	1	2		n	
		Different surfaces	Same surface	Different surfaces	Same surface
D-A9□ D-M9□ D-M9□W	10	15 ^{Note)}	45 ^{Note)}	$15 + 45 \frac{(n-2)}{2}$ (n = 2, 4, 6···)	45 + 45 (n - 2)
D-C7□ D-C80	10	15	50	$15 + 45 \frac{(n-2)}{2}$ (n = 2, 4, 6···)	50 + 45 (n - 2)
D-H7□ D-H7□W D-H7BAL D-H7NF	10	15	60	$15 + 45 \frac{(n-2)}{2}$ (n = 2, 4, 6···)	60 + 45 (n - 2)
D-C73C D-C80C D-H7C	10	15	65	$15 + 50 \frac{(n-2)}{2}$ (n = 2, 4, 6···)	65 + 50 (n - 2)
D-B5□/B64 D-G5□/K59 D-G5□W/K59W D-G5BAL D-G5NTL	10	15	75	$15 + 50 \frac{(n-2)}{2}$ (n = 2, 4, 6···)	75 + 55 (n - 2)
D-B59W	15	20	75	$20 + 50 \frac{(n-2)}{2}$ (n = 2, 4, 6···)	75 + 55 (n - 2)
D-A3□ D-A44 D-G39 D-K39	10	35	100	35 + 30 (n - 2)	100 + 100 (n - 2)

Note) When 2 D-A93/M9□/M9□W auto switches are used.

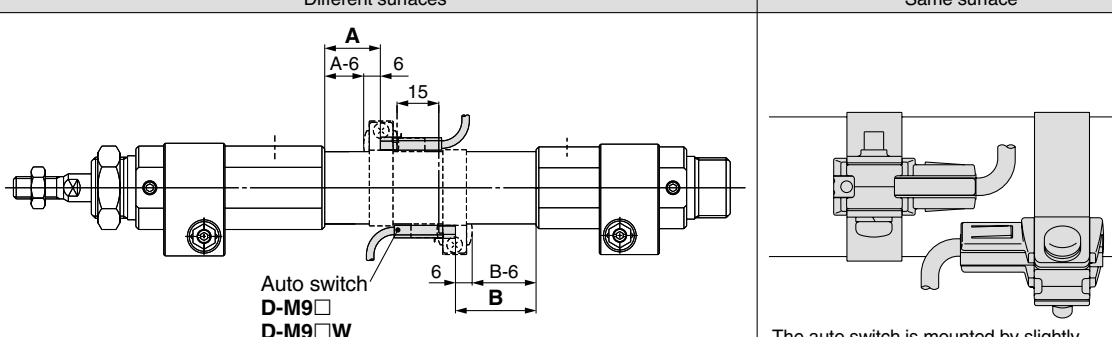
Auto switch model	2 auto switches	
	Different surfaces	Same surface
 <p>The proper auto switch mounting position is 6 mm inward from the switch holder edge.</p>	<p>The auto switch is mounted by slightly displacing it in a direction (cylinder tube circumferential exterior) so that the auto switch and lead wire do not interfere with each other.</p>	
D-A93	—	Less than 50 strokes
D-M9□ D-M9□W	Less than 20 strokes	Less than 55 strokes

REA

REB

REC

C□Y

C□X

MQ

RHC

RZQ

D-□

-X□

Individual
-X□

Series RHC

Auto Switch Proper Mounting Position (Detection at Stroke End) and Its Mounting Height

Reed auto switch

D-A9□

ø20 to 40

() : For D-A93 type

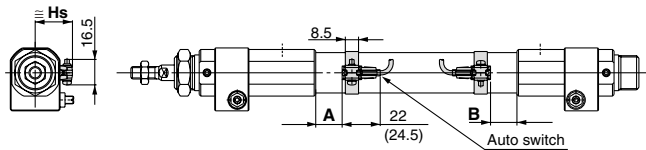

ø50 to 63

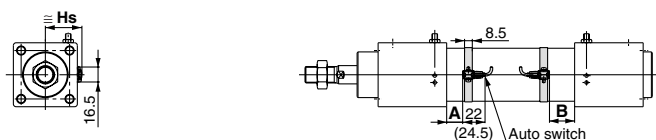

D-C7□, C80

ø20 to 40

() : For D-A93 type

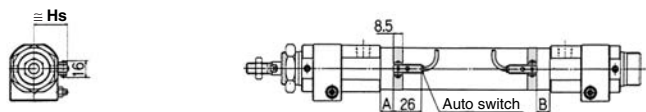

ø50 to 63

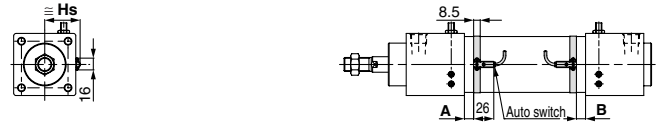

D-B5□, B64, B59W

ø20 to 40

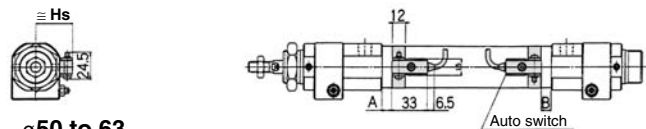

ø50 to 63

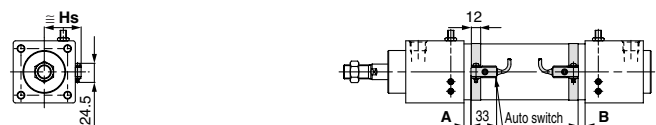

D-C73C, C80C

ø20 to 40

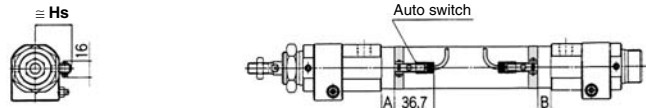

ø50 to 63

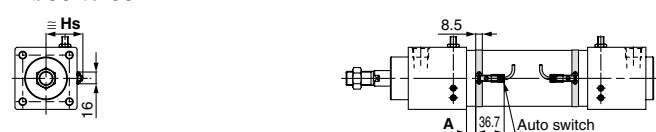

D-A3□, G39, K39

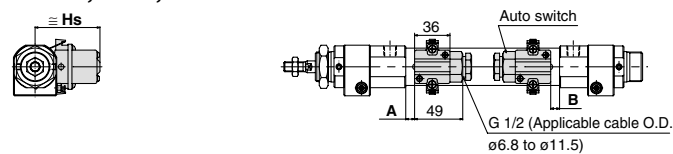

Solid state auto switch

D-M9□

D-M9□W

ø20 to 40

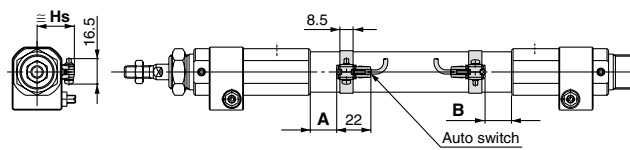

ø50 to 63

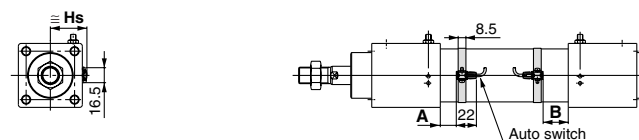

D-H7□, H7□W, H7NF, H7BAL

ø20 to 40

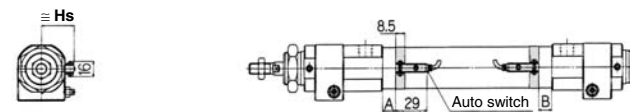

ø50 to 63

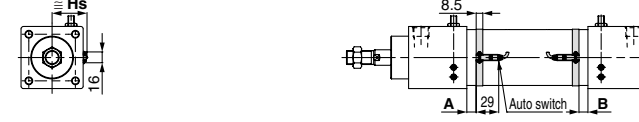

D-G5□, K59, G5□W, K59W, G5NTL, G5BAL

ø20 to 40

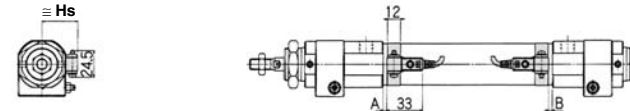

ø50 to 63

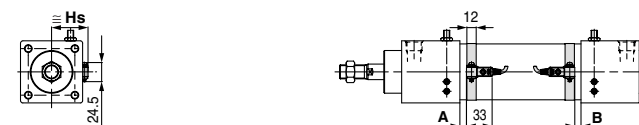

D-H7C

ø20 to 40

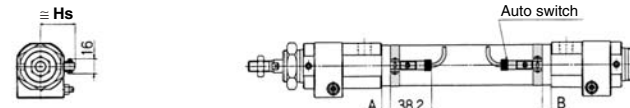

ø50 to 63

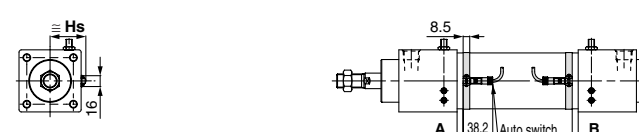

D-A44

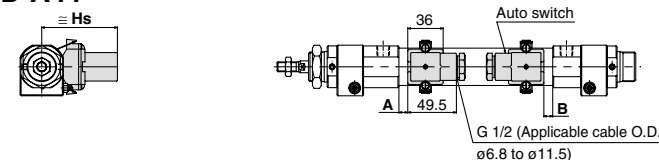

Auto Switch Proper Mounting Position (Detection at Stroke End) and Its Mounting Height

Auto Switch Proper Mounting Position

(mm)

Auto switch model Bore size (mm)	D-A9□		D-M9□ D-M9□W		D-C7□ D-C80 D-C73C D-C80C		D-B5□ D-B64		D-H7□ D-H7C D-H7NF D-H7□W D-H7BAL		D-G5□ D-G5□W D-G5NTL D-G5BAL D-K59 D-K59W		D-B59W		D-A33□ D-A44 D-G39 D-K39	
	A	B	A	B	A	B	A	B	A	B	A	B	A	B	A	B
20	14.5	20	18.5	24	15	20.5	9	14.5	14	19.5	10.5	16	12	17.5	8.5	14
25	14.5	20	18.5	24	15	20.5	9	14.5	14	19.5	10.5	16	12	17.5	8.5	14
32	14.5	22	18.5	26	15	22.5	9	16.5	14	21.5	10.5	18	12	19.5	8.5	16
40	19.5	27	23.5	31	20	27.5	14	21.5	19	26.5	15.5	23	17	24.5	13.5	21
50	17.5	27.5	21.5	31.5	18	28	12	22	17	27	13.5	23.5	15	25	11.5	21.5
63	17.5	27.5	21.5	31.5	18	28	12	22	17	27	13.5	23.5	15	25	11.5	21.5
80	—	—	—	—	—	—	13.5	27.5	—	—	15	29	16.5	30.5	13	27
100	—	—	—	—	—	—	15.5	29.5	—	—	17	31	18.5	32.5	15	29

Note) Adjust the auto switch after confirming the operating conditions in the actual setting.

Auto Switch Mounting Height

(mm)

Auto switch model Bore size (mm)	D-A9□ D-M9□ D-M9□W	D-C7□ D-C80 D-H7□ D-H7□W D-H7NF D-H7BAL	D-B5□/B64 D-B59W D-G5□/K59 D-G5□W D-K59W D-G5NTL D-G5BAL D-H7C	D-C73C D-C80C	D-A3□ D-G39 D-K39	D-A44
	Hs	Hs	Hs	Hs	Hs	Hs
20	24	24.5	27.5	27	62	72
25	26.5	27	30	29.5	64.5	74.5
32	30	30.5	33.5	33	68	78
40	34.5	35	38	37.5	72.5	82.5
50	40	40.5	43.5	43	78	88
63	47	47.5	50.5	50.5	85	95
80	—	—	59	—	93.5	103.5
100	—	—	69.5	—	104	114

REA

REB

REC

C□Y

C□X

MQ

RHC

RZQ

D-□

-X□

Individual
-X□

Series RHC

Operating Range

Auto switch model	Bore size (mm)							
	20	25	32	40	50	63	80	100
D-A9□	7	6	8	8	8	9	—	—
D-M9□ D-M9□W	3.5	3.5	4	4	5	5.5	—	—
D-C7□/C80 D-C73C/C80C	8	10	9	10	10	11	—	—
D-B5□/B64	8	10	9	10	10	11	11	11
D-B59W	13	13	14	14	14	17	16	18
D-H7□/H7NF/H7□W/H7BAL	4	4	4.5	5	6	6.5	6.5	7
D-H7C	7	8.5	9	10	9.5	10.5	10.5	11
D-A3□/A44	9	10	9	10	10	11	11	11
D-G39/K39	8	9	9	9	9	10	10	11
D-G5□/K59/G5□W D-K59W/G5BAL/G5NTL	4	4	4.5	5	6	6.5	6.5	7
D-G5NBL	35	40	40	45	45	45	45	50

* Since this is a guideline including hysteresis, not meant to be guaranteed. (Assuming approximately ±30% dispersion.) There may be the case it will vary substantially depending on an ambient environment.

Mounting Bracket Part No.

Auto switch model	Bore size (mm)							
	ø20	ø25	ø32	ø40	ø50	ø63	ø80	ø100
D-A9□ D-M9□ D-M9□W	Note 1) ①BMA2-020 ②BJ3-1	Note 1) ①BMA2-025 ②BJ3-1	Note 1) ①BMA2-032 ②BJ3-1	Note 1) ①BMA2-040 ②BJ3-1	Note 1) ①BMA2-050 ②BJ3-1	Note 1) ①BMA2-063 ②BJ3-1	—	—
D-C7□/C80 D-C73C D-C80C D-H7□ D-H7□W D-H7BAL D-H7NF	BMA2-020	BMA2-025	BMA2-032	BMA2-040	BMA2-050	BMA2-063	—	—
D-B5□/B64 D-B59W D-G5□/K59 D-G5□W/K59W D-G5BAL/G59F D-G5NTL D-G5NBL	BA-01	BA-02	BA-32	BA-04	BA-05	BA-06	BA-08	BA-10
D-A3□/A44 D-G39/K39	BD1-01M	BD1-02M	BD1-02	BD1-04M	BD1-05M	BD1-06M	BD1-08M	BD1-10M

Note 1) Two kinds of auto switch mounting brackets are used as a set.

[Mounting screw set made of stainless steel]

The following set of mounting screws made of stainless steel is available. Use it in accordance with the operating environment. (Please order the auto switch mounting bracket separately, since it is not included.)

BBA3: For D-B5/B6/G5/K5
BBA4: For D-C7/C8/H7

D-H7BAL/G5BAL auto switches are set on the cylinder with the stainless steel screws above when shipped. When an auto switch is shipped independently, BBA3 or BBA4 is attached.

Note 2) Refer to pages 1813 and 1814 for the details of BBA3 and BBA4.

Other than the applicable auto switches listed in “How to Order”, the following auto switches can be mounted. For detailed specifications, refer to pages 1719 to 1827.

Type	Model	Electrical entry (Fetching direction)	Features	Applicable bore size (mm)
Reed switch	D-C73, C76	Grommet (In-line)	—	ø20 to ø63
	D-C80		Without indicator light	
	D-B53		—	ø20 to ø100
Solid state switch	D-H7A1, H7A2, H7B	Grommet (In-line)	—	ø20 to ø63
	D-H7NW, H7PW, H7BW		Diagnostic indication (2-color indication)	
	D-G5NTL		With timer	ø20 to ø100

* For solid state auto switches, auto switches with a pre-wired connector are also available. Refer to pages 1784 and 1785 for details.

* Normally closed (NC = b contact) solid state auto switches (D-F9G/F9H types) are also available. Refer to page 1746 for details.

* Wide range detection type, solid state auto switches (D-G5NBL type) are also available. Refer to page 1776 for details.

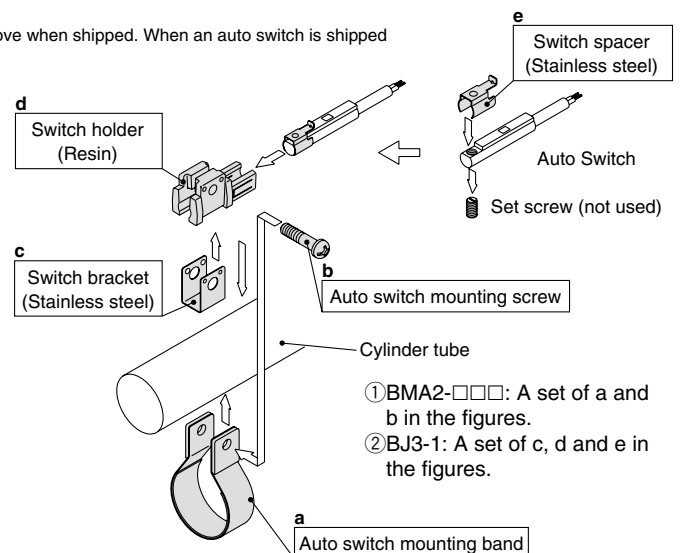



Series RHC Specific Product Precautions

Be sure to read before handling.

Refer to front matters 42 and 43 for Safety Instructions and pages 3 to 11 for Actuator and Auto Switch Precautions.

How to Rotate the Relief Valve Body (ø20, ø25, ø32, ø40)

⚠ Caution

The relief adjusting screw can be placed in any direction by rotating the relief valve body by following the steps given below.

Procedure

1. Verify that there is no residual pressure in the cylinder. Then, loosen the mounting bracket (such as foot, flange, etc.).
2. Loosen the set screw that is provided in the relief valve body retainer and rotate the relief valve body.
3. While keeping the relief valve body retainer pressed against the relief valve body, secure it with the set screw. After having secured the relief valve body retainer, make sure that the relief valve body cannot be rotated. In the event that it does rotate, loosen the set screw again and repeat the operation described in step 3.

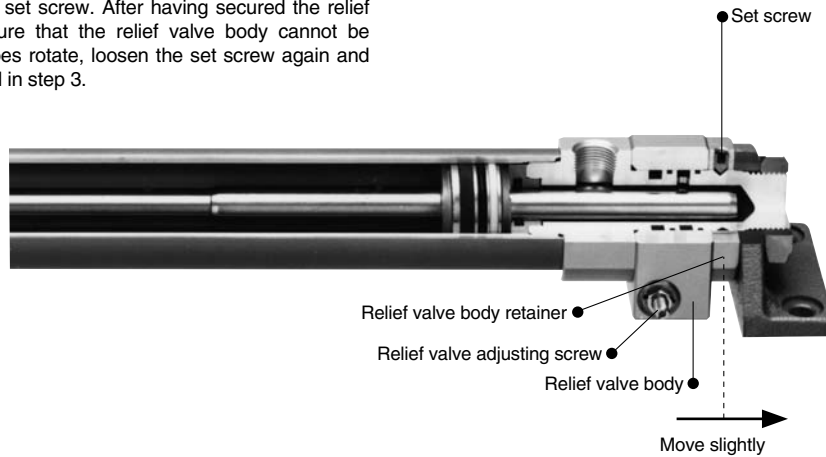

Handling

⚠ Caution

1. Confirm that the relief valve body does not rotate when the cylinder is mounted. If there is play in the axial direction of the relief valve body, the cushion may become ineffective. When attaching brackets (foot, flange), do so after loosening the relief valve body set screw. Retighten the relief valve body set screw after the brackets have been attached. (ø20, 25, 32, 40)
2. The cylinder stroke end cushion adjusting screw is adjusted six turns (10 turns for ø63, ø80 and ø100) starting from the position where it is rotated fully clockwise to counterclockwise (fully closed). It should never be rotated more than six turns (more than 10 turns for ø63, ø80 and ø100) from the position where it is rotated fully counterclockwise (fully open). This may damage the spring inside the relief valve.
3. The cylinder ports are designed so that a maximum speed 3000 mm/s can be obtained. However, it may not be possible to attain the desired speed in the case of short cylinder strokes. It may also be impossible to attain the desired speed due to restriction by component equipment (valves, speed control valves, piping, fitting, etc.). Make every effort to ensure sufficient effective area in the component equipment.
4. Avoid applications in which lateral loads are applied to the cylinder piston rod. Especially in the case of long strokes, implement measures such as providing a guide for the load.

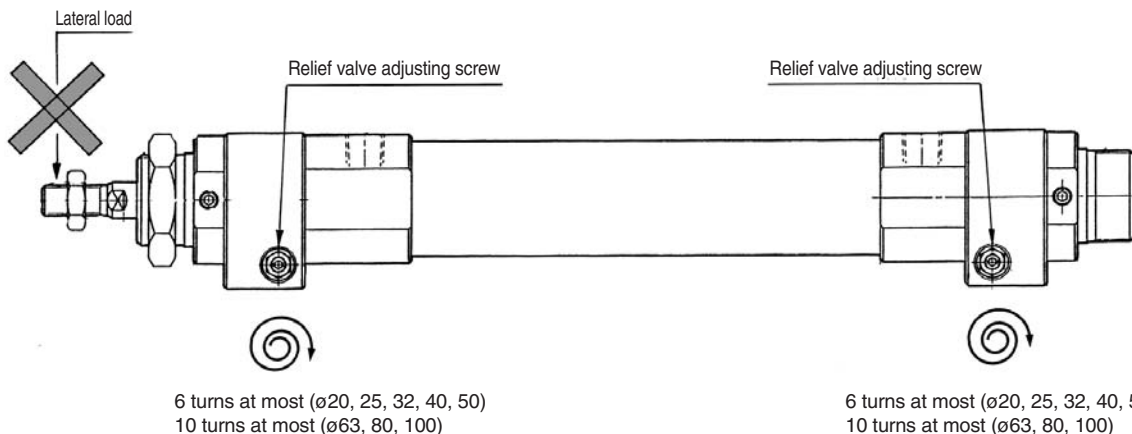

REA

REB

REC

C□Y

C□X

MQ

RHC

RZQ

D-□

-X□

Individual
-X□