

REVISIONS

P	LTR	DESCRIPTION	DATE	DWN	APVD
	A1	REVISED AS PER ECN-26-362051	06JAN2026	YS	WZ

MATERIALS AND PLATING THICKNESS UNIT: MICRO-INCHES (MINIMUM)		
PART NAME	MATERIALS	PLATING
BODY/SHELL	BRASS	SEE TEPN LIST
INSULATOR	ULTEM 1000	NATURAL
CONTACT PIN	BeCu	SEE TEPN LIST
RETAINER RING	BeCu	NICKEL 100µIN/COPPER 50µIN
CAP	LDPE	NATURAL

ELECTRICAL CHARACTERISTICS	
IMPEDANCE	50 Ω
VOLTAGE RATING	330 VRMS
FREQUENCY RANGE	DC~40GHz
DIELECTRIC WITHSTANDING VOLTAGE	500 VRMS Min
CONTACT RESISTANCE	CENTER CONTACT 3.0 mΩ Max
	OUTER CONTACT 2.0 mΩ Max
INSULATION RESISTANCE	5000 MΩ Min
INSERTION LOSS	0.4dB Max(DC-40GHz)
VSWR	1.3 Max(DC-40GHz)

MECHANICAL CHARACTERISTICS	
DURABILITY	500 cycles Min
ENGAGEMENT FORCE	0.23N.m Max
DISENGAGEMENT FORCE	0.23N.m Max

ENVIRONMENTAL PARAMETER	
TEMPERATURE RANGE	-65 °C~+165 °C
THERMAL SHOCK	MIL- STD 202, Meth. 107,Cond. B
VIBRATION	MIL- STD 202, Meth. 204,Cond. D
SHOCK	MIL- STD 202, Meth. 213,Cond. I
CORROSION	MIL- STD 202, Meth. 101,Cond. B

NOTES:
 1 BAY PACKAGING;
 2 ALL DIMENSIONS ARE NOMINAL FOR REFERENCE ONLY UNLESS OTHERWISE STATED;
 3 RoHS: COMPLIANT.

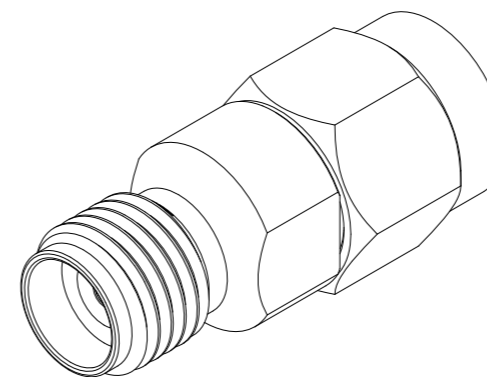
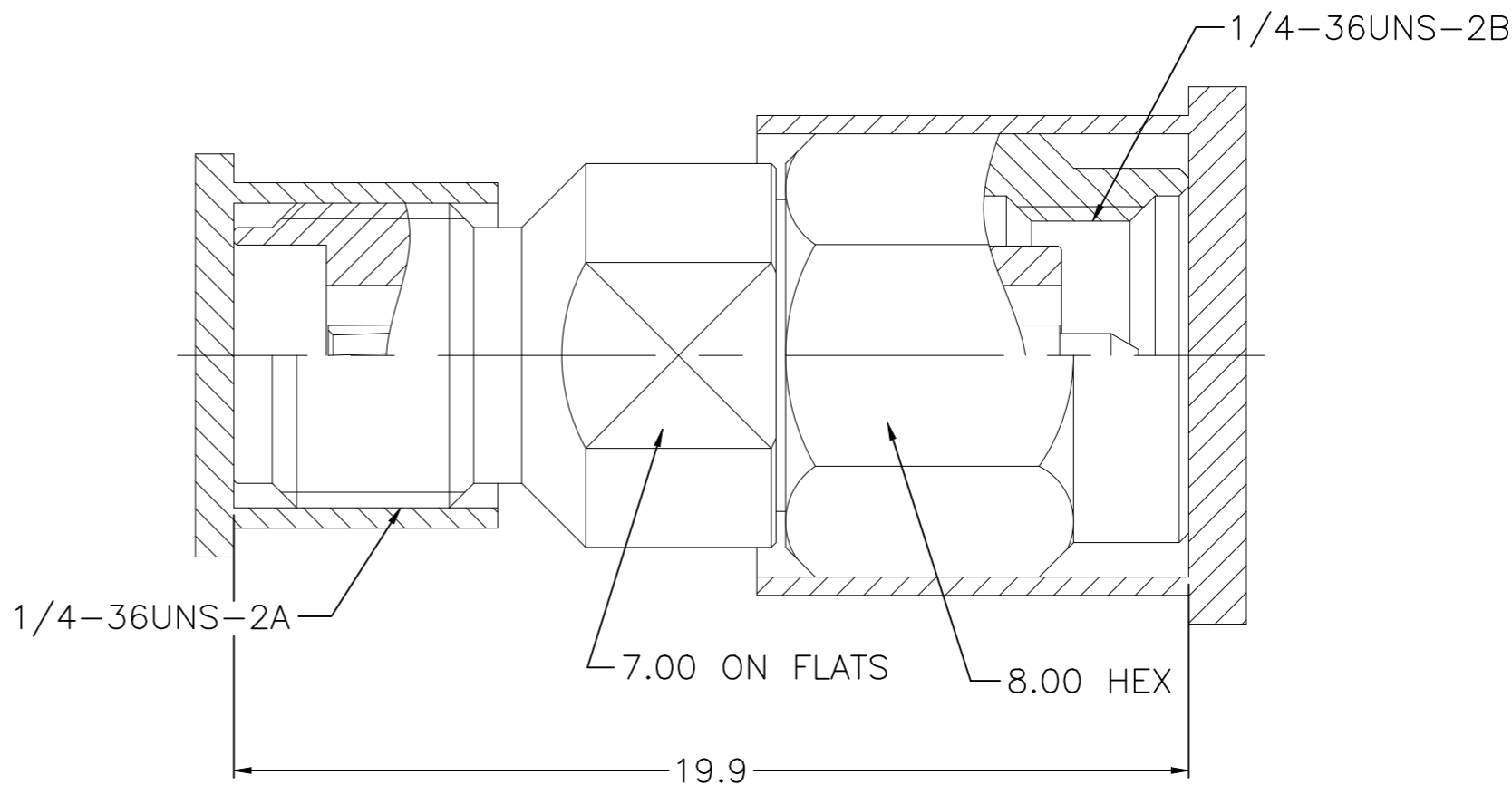

ELECTROLESS NICKEL 100µIN	GOLD 3µIN/ELECTROLESS NICKEL 100µIN	2523305-1
PLATING OF BODY AND SHELL	PLATING OF CONTACT PIN	PART NUMBER

THIS DRAWING IS A CONTROLLED DOCUMENT.		DWN ED 02SEP2025	TE Connectivity	
		CHK TP 02SEP2025		
		APVD ED 02SEP2025		
		PRODUCT SPEC		
DIMENSIONS: mm 		TOLERANCES UNLESS OTHERWISE SPECIFIED: 0 PLC ± 0.3 1 PLC ± 0.2 2 PLC ± 0.1 3 PLC ± 0.05 4 PLC ± - ANGLES ± -		NAME 2.92mm PLUG TO JACK ADAPTER
MATERIAL -		FINISH -		APPLICATION SPEC - SIZE A3 CAGE CODE 00779 DRAWING NO C-2523305 RESTRICTED TO -
		WEIGHT 0		SCALE 1:1
		CUSTOMER DRAWING		SHEET 1 OF 1
				REV A1