







semiconductor relay, 1-pole 3RF3 width 22.5 mm, 90 A 48-600 V 110-230 V AC spring-loaded terminal for mounting on available cooling surfaces

<b>product brand name</b>	SIRIUS
<b>product designation</b>	solid-state relay
<b>product type designation</b>	3RF31
<b>manufacturer's article number</b>	
<ul style="list-style-type: none"> <li>_1 of the accessories that can be ordered</li> </ul>	<a href="#">3RF3900-0WA88</a>
<b>product designation</b>	
<ul style="list-style-type: none"> <li>_1 of the accessories that can be ordered</li> </ul>	heat conducting foil
<b>General technical data</b>	
<b>product function</b>	zero-point switching
<b>product feature</b>	high blocking voltage
<b>power loss [V·A] maximum</b>	83 VA
<b>power loss [W] for rated value of the current</b>	
<ul style="list-style-type: none"> <li>at AC in hot operating state</li> </ul>	19 W
<ul style="list-style-type: none"> <li>at AC in hot operating state per pole</li> </ul>	19 W
<ul style="list-style-type: none"> <li>without load current share typical</li> </ul>	3.5 W
<b>insulation voltage rated value</b>	600 V
surge voltage resistance of main circuit rated value	6 kV
<b>protection class IP</b>	IP20
protection class IP on the front according to IEC 60529	IP20
<b>shock resistance according to IEC 60068-2-27</b>	15g / 11 ms
<b>vibration resistance according to IEC 60068-2-6</b>	2g
<b>reference code according to IEC 81346-2</b>	Q
<b>Substance Prohibitation (Date)</b>	01/15/2024
<b>SVHC substance name</b>	Lead - 7439-92-1 Lead monoxide (lead oxide) - 1317-36-8
<b>Net Weight</b>	0.08 kg
<b>Main circuit</b>	
<b>number of poles for main current circuit</b>	1
<b>number of NO contacts for main contacts</b>	1
<b>number of NC contacts for main contacts</b>	0
<b>type of voltage of the operating voltage</b>	AC
<b>operating voltage</b>	
<ul style="list-style-type: none"> <li>at AC</li> </ul>	
<ul style="list-style-type: none"> <li>at 50 Hz rated value</li> </ul>	48 ... 600 V
<ul style="list-style-type: none"> <li>at 60 Hz rated value</li> </ul>	48 ... 600 V
<b>operating frequency rated value</b>	50 ... 60 Hz
<b>relative symmetrical tolerance of the operating frequency</b>	10 %
<b>operating range relative to the operating voltage at AC</b>	
<ul style="list-style-type: none"> <li>at 50 Hz</li> </ul>	40 ... 660 V

• at 60 Hz	40 ... 660 V
<b>operational current rated value maximum</b>	20 A
<b>operational current</b>	
• at AC-1 at 400 V rated value	20 A
• at AC-51 rated value	20 A
• at AC-51 according to IEC 60947-4-3	20 A
• according to UL 508 rated value	20 A
<b>ampacity maximum</b>	90 A
<b>operational current minimum</b>	500 mA
<b>rate of voltage rise at the thyristor for main contacts maximum permissible</b>	1 000 V/ $\mu$ s
<b>blocking voltage at the thyristor for main contacts maximum permissible</b>	1 600 V
<b>reverse current of the thyristor</b>	10 mA
<b>derating temperature</b>	40 °C
<b>surge current resistance rated value</b>	1 300 A
<b>I<sup>2</sup>t value maximum</b>	8 000 A <sup>2</sup> ·s
<b>Control circuit/ Control</b>	
<b>type of voltage of the control supply voltage</b>	AC
<b>control supply voltage at AC</b>	
• at 50 Hz	110 ... 230 V
• at 60 Hz	110 ... 230 V
<b>control supply voltage 1 at AC</b>	
• at 50 Hz	110 ... 230 V
• at 60 Hz	110 ... 230 V
<b>control supply voltage frequency</b>	
• 1 rated value	50 Hz
• 2 rated value	60 Hz
<b>control supply voltage at AC</b>	
• at 50 Hz full-scale value for signal<0> recognition	40 V
• at 60 Hz full-scale value for signal<0> recognition	40 V
<b>control supply voltage</b>	
• at AC initial value for signal <1> detection	90 V
<b>symmetrical line frequency tolerance</b>	5 Hz
<b>operating range factor control supply voltage rated value at AC at 50 Hz</b>	
• initial value	0.82
<b>operating range factor control supply voltage rated value at AC at 60 Hz</b>	
• initial value	0.82
<b>control current at minimum control supply voltage</b>	
• at AC	2 mA
control current at AC rated value	15 mA
<b>ON-delay time</b>	40 ms; additionally max. one half-wave
<b>OFF-delay time</b>	40 ms; additionally max. one half-wave
<b>Installation/ mounting/ dimensions</b>	
fastening method side-by-side mounting	Yes
<b>fastening method</b>	screw fixing
<b>design of the thread of the screw for securing the equipment</b>	M4
<b>tightening torque of fixing screw maximum</b>	1.5 N·m
<b>tightening torque [lbf·in] of fixing screw maximum</b>	13 lbf·in
<b>height</b>	85 mm
<b>width</b>	22.5 mm
<b>depth</b>	48 mm
<b>Connections/ Terminals</b>	
<b>product component removable terminal for auxiliary and control circuit</b>	Yes
<b>type of electrical connection</b>	
• for main current circuit	spring-loaded terminals

<ul style="list-style-type: none"> <li>• for auxiliary and control circuit</li> </ul>	spring-loaded terminals				
<b>type of connectable conductor cross-sections</b> <ul style="list-style-type: none"> <li>• for main contacts <ul style="list-style-type: none"> <li>— solid</li> <li>— finely stranded with core end processing</li> <li>— finely stranded without core end processing</li> </ul> </li> <li>• for AWG cables for main contacts</li> </ul>	2x (0.5 ... 2.5 mm <sup>2</sup> ) 2x (0.5 ... 1.5 mm <sup>2</sup> ) 2x (0.5 ... 2.5 mm <sup>2</sup> ) 2x (18 ... 14)				
<b>connectable conductor cross-section for main contacts</b> <ul style="list-style-type: none"> <li>• solid or stranded</li> <li>• finely stranded with core end processing</li> <li>• finely stranded without core end processing</li> </ul>	0.5 ... 2.5 mm <sup>2</sup> 0.5 ... 1.5 mm <sup>2</sup> 0.5 ... 2.5 mm <sup>2</sup>				
<b>type of connectable conductor cross-sections</b> <ul style="list-style-type: none"> <li>• for auxiliary and control contacts <ul style="list-style-type: none"> <li>— solid</li> <li>— finely stranded with core end processing</li> <li>— finely stranded without core end processing</li> </ul> </li> <li>• for AWG cables for auxiliary and control contacts</li> </ul>	0.5 ... 1.5 mm <sup>2</sup> 0.5 ... 2.5 mm <sup>2</sup> 0.5 ... 2.5 mm <sup>2</sup> 1x (20 ... 12)				
<b>AWG number as coded connectable conductor cross section for main contacts</b>	18 ... 14				
<b>stripped length of the cable</b> <ul style="list-style-type: none"> <li>• for main contacts</li> <li>• for auxiliary and control contacts</li> </ul>	10 mm 10 mm				
<b>Electrical Safety</b>					
<b>protection class IP on the front according to IEC 60529</b>	IP20				
<b>touch protection on the front according to IEC 60529</b>	finger-safe, for vertical contact from the front				
<b>Ambient conditions</b>					
installation altitude at height above sea level maximum	1 000 m				
<b>ambient temperature</b> <ul style="list-style-type: none"> <li>• during operation</li> <li>• during storage</li> </ul>	-25 ... +60 °C -55 ... +80 °C				
<b>Electromagnetic compatibility</b>					
<b>conducted interference</b> <ul style="list-style-type: none"> <li>• due to burst according to IEC 61000-4-4</li> <li>• due to conductor-earth surge according to IEC 61000-4-5</li> <li>• due to conductor-conductor surge according to IEC 61000-4-5</li> <li>• due to high-frequency radiation according to IEC 61000-4-6</li> </ul>	2 kV / 5 kHz behavior criterion 2 2 kV behavior criterion 2 1 kV behavior criterion 2 140 dBuV in the frequency range 0.15 ... 80 MHz, behavior criterion 1				
<b>field-based interference according to IEC 61000-4-3</b>	80 MHz ... 1 GHz 10 V/m, behavior criterion 1				
<b>electrostatic discharge according to IEC 61000-4-2</b>	4 kV contact discharging / 8 kV air discharging, behavior criterion 2				
<b>conducted HF interference emissions according to CISPR11</b>	Class A for industrial environment				
<b>field-bound HF interference emission according to CISPR11</b>	Class B for the domestic, business and commercial environments				
<b>Short-circuit protection, design of the fuse link</b>					
manufacturer's article number <ul style="list-style-type: none"> <li>• of gS fuse for semiconductor protection at NH design usable</li> <li>• of back-up R fuse link for semiconductor protection at NH design usable</li> <li>• of back-up R fuse link for semiconductor protection at cylindrical design 22 x 58 mm usable</li> </ul>	<a href="#">3NE1818-0; These fuses have a smaller rated current than the semiconductor relays</a> <a href="#">3NE8021-1</a> <a href="#">3NC2280; These fuses have a smaller rated current than the semiconductor relays</a>				
manufacturer's article number of the gG fuse <ul style="list-style-type: none"> <li>• at NH design usable</li> </ul>	<a href="#">3NA6812-6; These fuses have a smaller rated current than the semiconductor relays</a>				
<b>Approvals Certificates</b>					
Environment	General Product Approval	EMV	Test Certificates		
<a href="#">Environmental Conformations</a>	 EG-Konf.	 UR	 EAC	 RCM	<a href="#">Type Test Certificates/Test Report</a>

[Confirmation](#)



Further information

Information on the packaging

<https://support.industry.siemens.com/cs/ww/en/view/109813875>

Information for data generation and storage

<https://support.industry.siemens.com/cs/ww/en/view/109995012>

Information- and Downloadcenter (Catalogs, Brochures,...)

<https://www.siemens.com/ic10>

Industry Mall (Online ordering system)

<https://mall.industry.siemens.com/mall/en/en/Catalog/product?mlfb=3RF3190-2AA26>

Cax online generator

<https://support.automation.siemens.com/WW/CAXorder/default.aspx?lang=en&mlfb=3RF3190-2AA26>

Service&Support (Manuals, Certificates, Characteristics, FAQs,...)

<https://support.industry.siemens.com/cs/ww/en/ps/3RF3190-2AA26>

Image database (product images, 2D dimension drawings, 3D models, device circuit diagrams, EPLAN macros, ...)

[https://www.automation.siemens.com/bilddb/cax\\_de.aspx?mlfb=3RF3190-2AA26&lang=en](https://www.automation.siemens.com/bilddb/cax_de.aspx?mlfb=3RF3190-2AA26&lang=en)

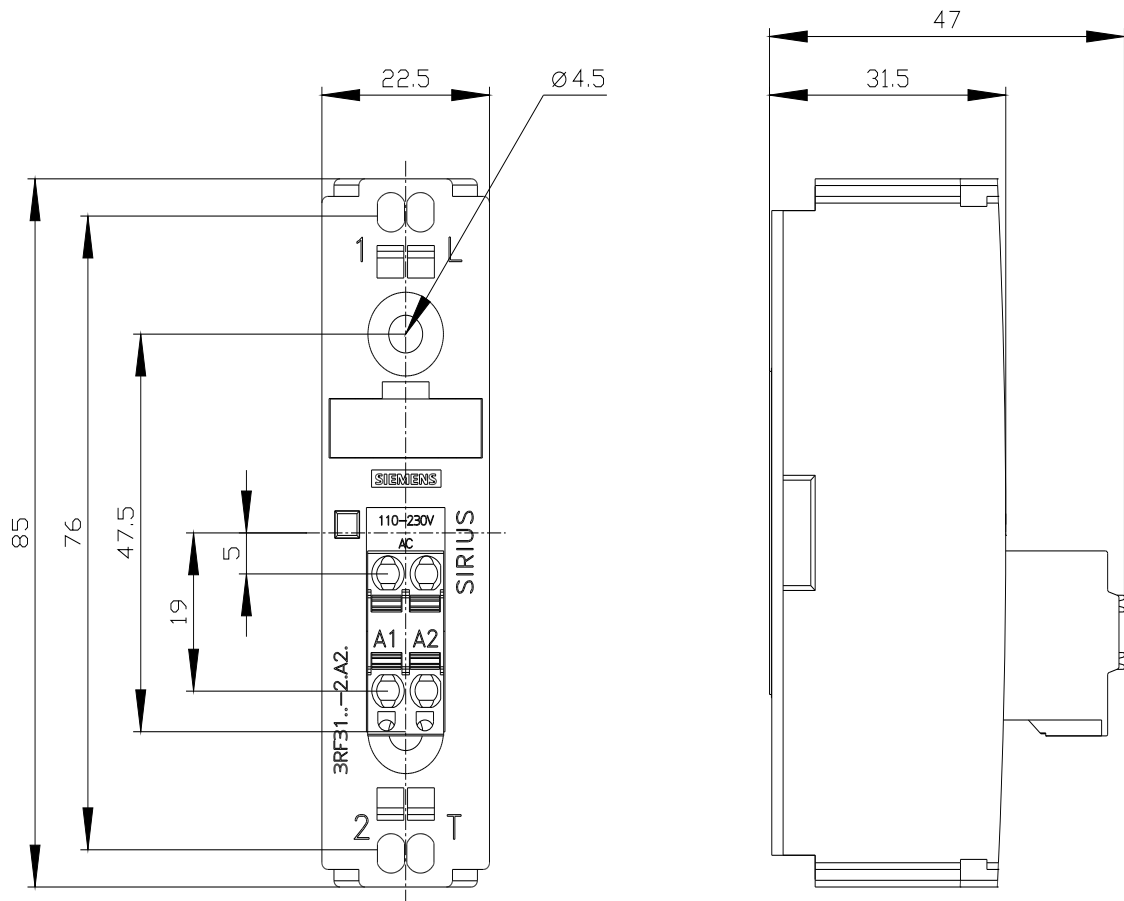

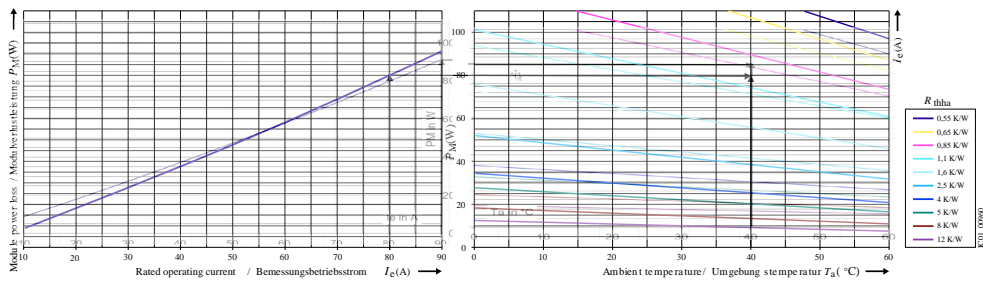
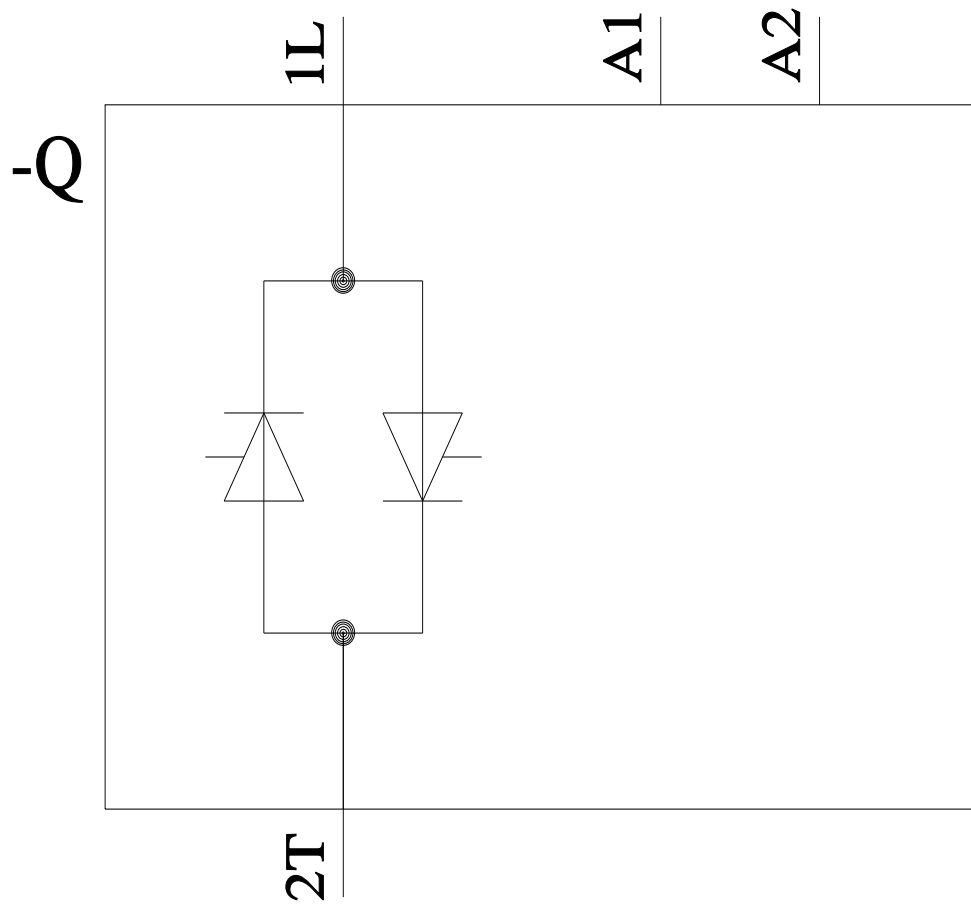

last modified:

1/22/2026