

# Amphenol PCD

<b>Engineering Change Request</b>		ECR Number	26003W	
Initiator:	Kane	Date:	2026.03.19	
Part number description				
Item	K3 Code <b>material part numbers</b>	Drawing/ Doc Number	Version of current related document	New Version
1	MSD Series	/	/	/
2	HVSL630 Series	/	/	/
3	HVSL280 Series	/	/	/
4	HVSL600 Series	/	/	/
Reason of change:				
<input type="checkbox"/> Customer requirement (list the feasibility analysis of customer specification: _____)				
<input type="checkbox"/> Supplier request (list the PCR number: _____ )				
<input type="checkbox"/> internal improvement <input type="checkbox"/> corrective <input checked="" type="checkbox"/> other				
<u>Please describe here in detail:</u>				
<b><u>Item 1–4: The current grey PA66 plastic raw material used in this product series is no longer available with reliable supply due to force majeure events. To ensure uninterrupted production and maintain consistent functional performance, we will transition to black PA66 plastic as a fully qualified substitute. Consequently, the housing color of the affected components will be standardized to black.</u></b>				
Change level and impact assessment (Please tick in the appropriate position)				
Change level	Change content	Concerned area(Shenzhen, Hermosillo, Chennai)	Whether to notify the customer	
Level 1	<input type="checkbox"/> Operator change		<input type="checkbox"/> It is not necessary to notify the customer for approval	
	<input type="checkbox"/> Correct the clerical errors of the drawing, BOM, etc., and this change will not affect the production process			
Level 2	<input type="checkbox"/> Change of Main production equipment or tools/Jigs		<input checked="" type="checkbox"/> <b>Customers should be notified for approval</b> <input type="checkbox"/> It is not necessary to notify the customer for approval, the reasons are as follows:	
	<input type="checkbox"/> Change of main measuring equipment or tools/Jigs			
	<input type="checkbox"/> Appearance changes that do not affect product functions			
	<input type="checkbox"/> Changes in production process or processing technology			
	<input type="checkbox"/> Product structure or specification changes that have not been transferred to mass production			
	<input type="checkbox"/> Product structure or specification changes that have been transferred to mass production			
Level 3	<input checked="" type="checkbox"/> Supplier's production process change or supplier's production site change or addition or replacement of suppliers		<input type="checkbox"/> Customers should be notified for approval	
	<input type="checkbox"/> Change of production site			
	<input type="checkbox"/> Product material changes			
	<input type="checkbox"/> Change of packaging method			
	<input type="checkbox"/> Changes proposed by the customer			

# Amphenol PCD

**Before change**  
The plastic raw material supplier is Sabic.  
(Grey)

**Item 1 MSD Series**

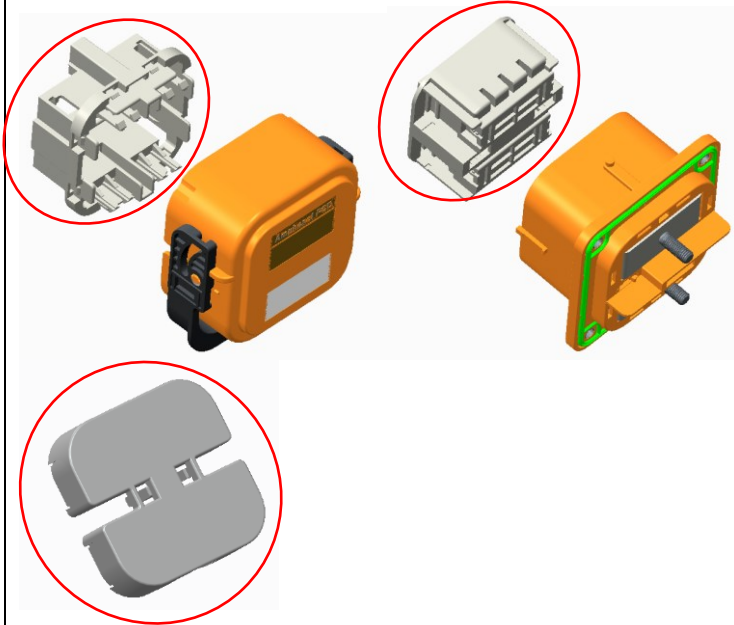

**Item 2 HVSL630 Series**

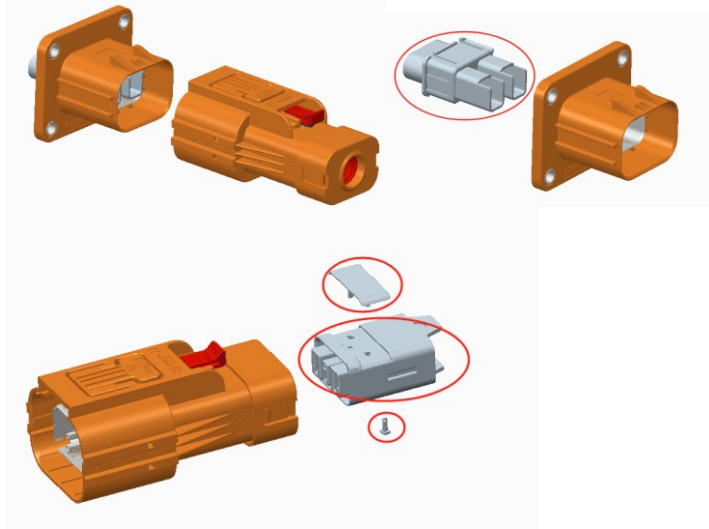

**Item 3 HVSL280 Series**

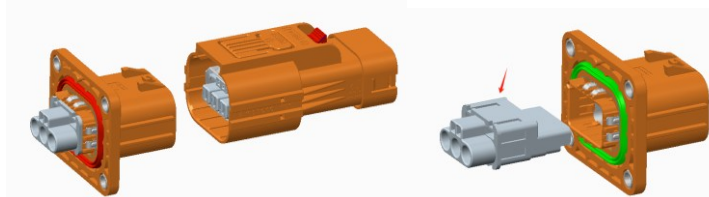

**After change**  
The plastic raw material supplier is DOMO.  
(Black)

**Item 1 MSD Series**

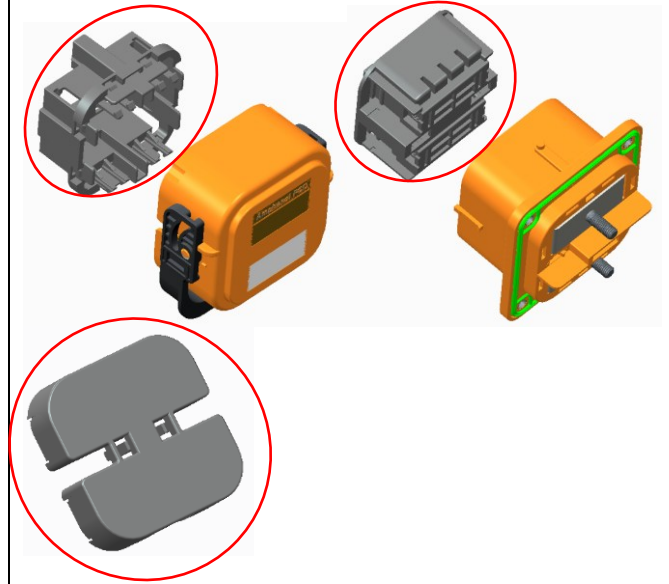

**Item 2 HVSL630 Series**

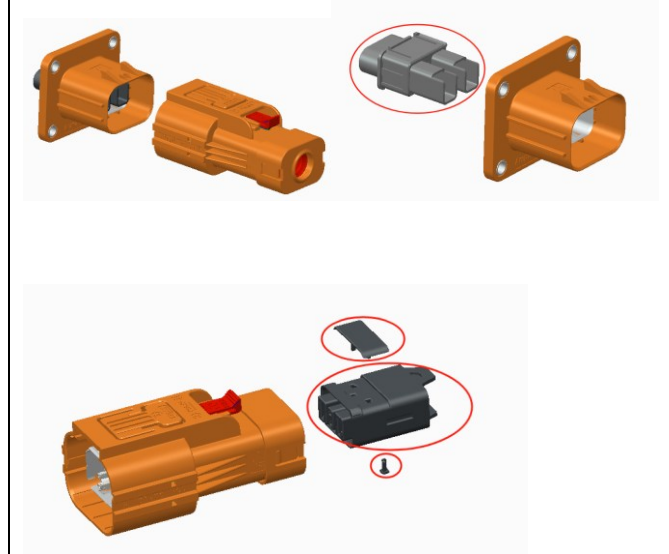

**Item 3 HVSL280 Series**

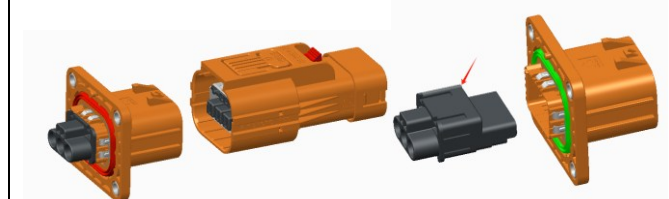

# Amphenol PCD

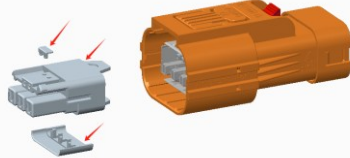
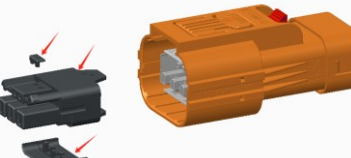
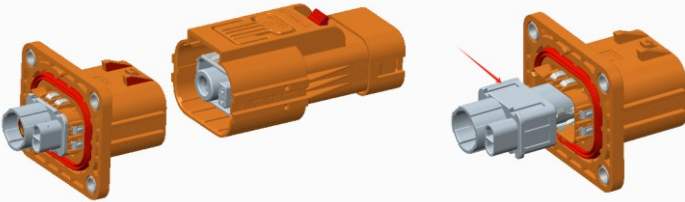
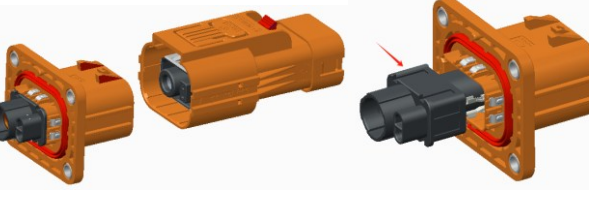
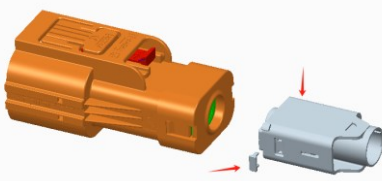
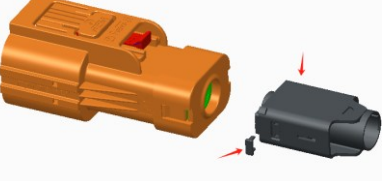
		
<p><b>Item 4 HVSL600 Series</b></p>	<p><b>Item 4 HVSL600 Series</b></p>	
		
		
<p>Disposition of old materials</p> <p> <input type="checkbox"/> Rework            <input checked="" type="checkbox"/> Use as it is            <input type="checkbox"/> scrap  <input type="checkbox"/> Other (please describe): _____  <input type="checkbox"/> N/A       </p>		<p>Expect date to switch to new material</p> <p><u>2026.05.30</u></p>
<p>Approval by the supervisor of requester.:</p> <p style="text-align: center;"><i>Derek</i></p>	<p>Approval by the head manager of the request dept.:</p> <p style="text-align: center;"><i>Chang</i></p>	
<p>Customer approval:</p> <p> <input type="checkbox"/> Approved            <input type="checkbox"/> No approved            <input type="checkbox"/> Conditional approval (please describe) :       </p> <p>Signature: _____ Date: _____</p>		
<p>Remark:</p>		