

MINITEC POWER LOCK FASTENER SF

Article Nr. 21.0818/0100

See the product on the website →

Download CAD Files →

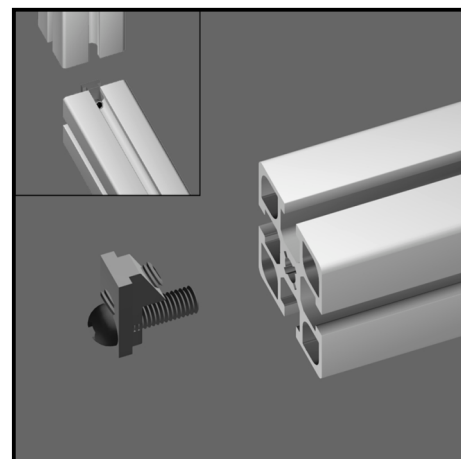
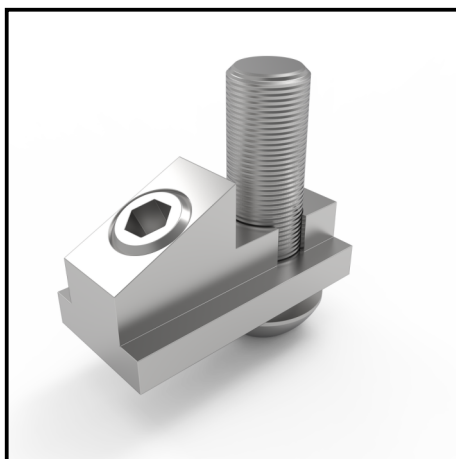
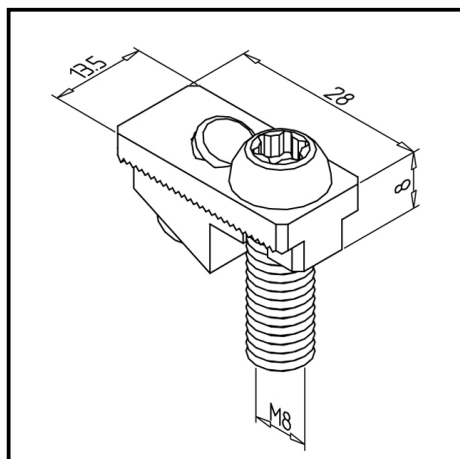

TECHN. DATA / ITEMS SUPPLIED

- Steel, galvanized
- Pack of 100, smaller quantities with **article no. [21.0818/0](#)**
- Self tapping torx screw T40
- Power-lock fastener 45 (standard) **part no. [21.1018/0](#)**, with filister head screw SW 5
- Power-Lock fastener 45 H - stainless version **part no. [21.1018/1](#)**, with button head screw SW 5
- Weight = 3.291 kg/KanTainer

APPLICATIONS

- Power-lock connection for all profiles, also suitable for crossjoints
- For larger profile sections several fasteners can be used
- Appropriate for ESD implementations

ASSEMBLY

- Fasten the connector frontally to the profile with the torx wrench T 40
- Tighten the set screw M8 with the wrench SW 4
- Recommended locking torque: 12 Nm
- For screwing in self-tapping screws for power-lock fastener: Impulse wrench **Art. no. [26.0800/0](#)** for particularly low impact on the user's wrists