

## XIM

Inline mixed flow extract fans for domestic ducted applications



### Overview

Available in four sizes, the Xpelair XIM range of plastic mixed flow units offers duties for a wide range of ducted applications. The two timer models have an adjustable overrun timer (3 to 15 mins).

All models come complete with a convenient mounting cradle which makes installation or subsequent inspection simple.

The terminal box is easily accessible simplifying the electrical connection. XIM100 and XIM100T units are IPX2 rated.

All other models are IPX4 rated for use in wet room ducted applications.

### Dimensions (mm)

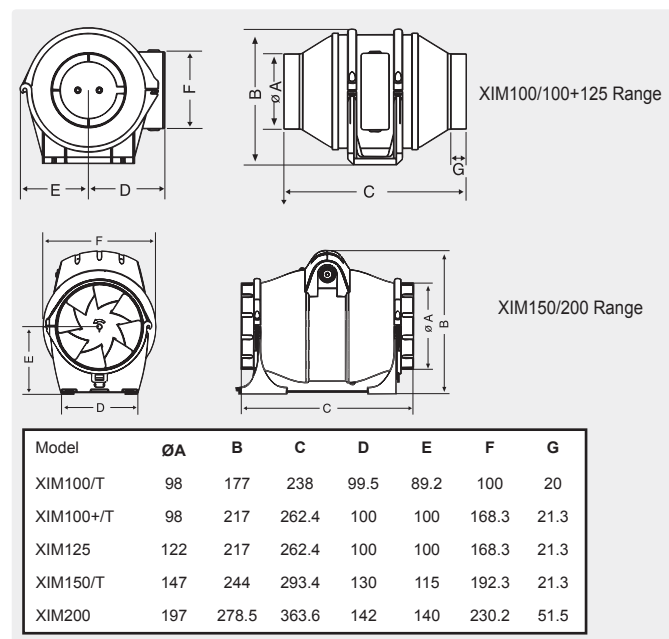

### Models

**XIM100** Ref. 91252AW  
Single speed inline fan | Mixed flow impeller/guide vanes | Integral mounting cradle | IPX2 rated

**XIM100T** Ref. 91253AW  
Single speed inline fan with adjustable overrun timer from 3-15 mins | Timer located in the terminal box | Triggered by lighting circuit | Mixed flow impeller/guide vanes | Integral mounting cradle | IPX2 rated

**XIM100+** Ref. 91254AW  
High performance 2 speed inline fan | Mixed flow impeller/guide vanes | Integral mounting cradle | IPX4 rated

**XIM100+T** Ref. 91473AW  
Two speed inline shower fan system | Built-in overrun timer (adjustable at installation from 2-20 mins) | Operated by remote switch or sensor | IPX4 rated

**XIM125** Ref. 91255AW  
2 speed inline fan | Mixed flow impeller/guide vanes | Integral mounting cradle | IPX4 rated

**XIM150** Ref. 91256AW  
2 speed inline fan | Mixed flow impeller/guide vanes | Plastic construction | Integral mounting cradle | IPX4 rated

**XIM150T** Ref. 91257AW  
Adjustable overrun timer from 3-15 mins | 2 speed inline fan | Timer located in the terminal box | Timer triggered by lighting circuit | Mixed flow impeller/guide vanes | Integral mounting cradle | IPX4 rated

**XIM200** Ref. 91258AW  
2 speed inline fan | Mixed flow impeller/guide vanes | Integral mounting cradle | IPX4 rated

### Key features

- Eight model range
- XIM100 standard single speed model (21 l/s)
- XIM100T timer single speed model (21 l/s)
- XIM100+ plus two speed model (53 l/s - 70 l/s)
- XIM100+T plus timer two speed model (53 l/s - 70 l/s)
- XIM125 standard two speed model (55 l/s - 74 l/s)
- XIM150 standard two speed model (99 l/s - 132 l/s)
- XIM150T timer two speed model (99 l/s - 132 l/s)
- XIM 200 standard two speed model (166 l/s - 235 l/s)
- All models supplied with convenient installation mounting cradle
- Lubricated for life, maintenance free motors
- Thermal cut-out safety protection
- IPX4 rated (except XIM100 & XIM100T - IPX2 rated)

Product Selector	XIM100	XIM100T	XIM100+	XIM100+T	XIM125	XIM150	XIM150T	XIM200
Reference number	91252AW	91253AW	91254AW	91473AW	91255AW	91256AW	91257AW	91258AW
Speeds	1	1	2	2	2	2	2	2
Max. electrical power rating (W)	25	25	25	25	25	80	80	80
Duct size (mm)	100	100	100	100	125	150	150	200
IP rating	IPX2	IPX2	IPX4	IPX4	IPX4	IPX4	IPX4	IPX4
Weight (kg)	1.2	1.2	2.1	2.1	2.1	3.2	3.2	4.5
UK Guarantee (years)	2	2	2	2	2	2	2	2
Max. extract performance (FID m³/h)	77	77	251	251	265	476	476	845
Min. extract performance (FID m³/h)			190	190	198	358	358	599
Max. extract performance (FID l/s)	21	21	70	70	74	132	132	235
Min. extract performance (FID l/s)			53	53	55	99	99	166
Max. sound pressure level (dB(A)@3m)	14	14	22	22	25	39	39	39