

Rotational Absolute Magnetic Kit Encoder Version 60 mm HP Position Sensor Version 2.1

LINKS TO ADDITIONAL RESOURCES

[3D Models](#)

QUICK REFERENCE DATA	
Sensor type	ROTATIONAL, magnetic technology
Output type	Connector Würth Elektronik 687106182122 to plug a flat flex cable or connector Hirose DF58-6P-1.2V(21) to plug an external connector equipped of wires
Market appliance	Industrial
Dimensions	Diameter 60 mm

FEATURES

- Especially dedicated to robotics applications
- High precision, high repeatability, high resolution, single or multi-turns variant
- Plug and play or self-calibration
- Memorization of last position before power off
- Not sensitive to external magnetic fields and temperature
- Not sensitive to moisture and pollution
- Especially dedicated for harsh conditions (vibrations, shocks, CEM...)
- Built-in self-monitoring
- Hall effect principle
- Option back-up battery connector
- Protected design, patent EP 2711663
- Material categorization: for definitions of compliance please see www.vishay.com/doc?99912



ELECTRICAL SPECIFICATIONS	
PARAMETER	
Voltage power supply (on sensor connector)	5 V ± 0.5 V
Supply current at 5 V	≤ 150 mA
Standard output format	SSI
Optional output format	Biss-C or SPI
Useful electrical angle	360°
Accuracy at 25 °C	Better than 13 bits (0.044°)
Repeatability	> 16 bits
Resolution	19 bits (0.0007°)
Startup time	≤ 20 ms
Data latency time	≤ 200 µs
Maximum sampling rate	10 kHz ± 2 % (without multi-turns option)
Optional multi-turn counter without external battery	16 bits counter
For multi-turns options	Memorization of the last angle value and the multi-turns counter at the power off
On request: multi-turns counter with external backup battery (not supplied)	16 bits counter, battery: voltage 3.6 V to 5 V, I _{max} . 15 mA

MECHANICAL SPECIFICATIONS (All Versions)	
PARAMETER	
Mechanical angle	360°
Maximum speed rotation	10 000 rpm (mechanical limits)
Rotor weight	< 40 g
Stator weight	< 15 g



SAP PART NUMBERING GUIDELINES										
TYPE	MODEL	DESIGN	SIZE (mm)	TYPE	FUNCTION	ACCURACY (BITS)	RESOLUTION (BITS)	OUTPUT	PACKAGING	OPTION
R = rotational	AM	K = kit	060	M	1	13	19	F = SPI CCW J = SSI CCW L = Biss-C	B = box	
								F = SPI CCW	B = box	661 = multi-turn counting
								J = SSI CCW	B = box	663 = multi-turn counting
								L = Biss-C	B = box	659 = multi-turn counting

Note

- “Multi-turn with connection back-up battery” possible on request, please contact Vishay

PERFORMANCE	
PARAMETER	
Standard operating temperature range	-40 °C to +85 °C
Storage temperature range	-55 °C to +105 °C
Humidity	≤ 80 % no condensing
Environmental protection	Coating on PCB components side
Vibrations	0.05 g ² /Hz, 20 Hz to 2000 Hz for 1 hour along three major axis
Shocks	100 g, 14 ms, ½ sine (one on each axis)
Magnetic protection	- No influence up to 3 mT (typical value) (uniform magnetic field) - No permanent deviation greater than 0.03° if a magnet of 50 mT was in contact with the upper metallic shape of the rotor - No permanent deviation greater than 0.03° if a magnet of 50 mT was exposed at 5 mm of the magnetic rubber

COMMUNICATION INTERFACES

Three protocols are possible: SSI protocol, Biss-C protocol, or SPI protocol.

Connector Types

Connector to plug a flat flex cable: output connector FCC pitch 0.5 mm, thickness 0.3 mm bottom contacts connector Würth Elektronik 687106182122

Connector to plug an external connector equipped of wires: output connector wires connector on the PCB: Hirose DF58-6P-1.2V(21)

- User crimp socket: Hirose DF58-6S-1.2C
- User crimp contact: Hirose DF58-2830SCF

Recommended FCC (customer side)

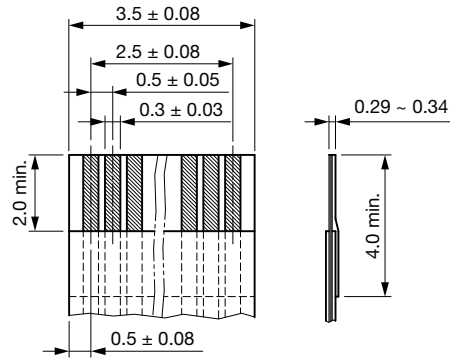

Fig. 1 - Recommended FCC

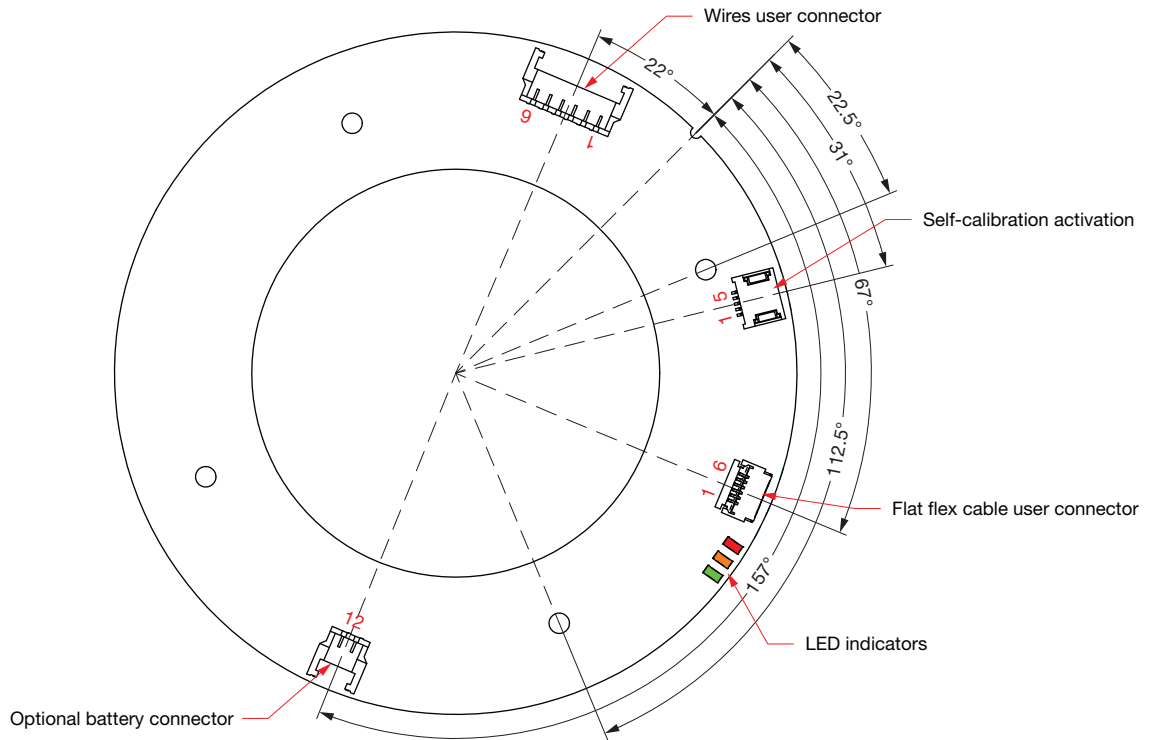

Fig. 2 - User Connectors

**SELF-MONITORING**

All frame includes 3 status bits. These 3 status bits form a 3 bits word.

3 BITS STATUS WORD								
	BIT A1	BIT A2	BIT A3	DECIMAL VALUE	LED STATUS	INFORMATION	ACTION	PRIORITY LEVEL
	MSB		LSB					
Normal operation	0	0	0	0	Green	Frame without error or warning.	No action required.	-
Temperature overflow	0	1	1	3	Red	This error is set if the temperature of the sensor is superior to +85 °C or inferior to -40 °C. This information is sent until temperature is over range.	Set the environmental temperature between -40 °C to +85 °C .	1 (highest)
Mechanical mounting error	0	0	1	1	Red	This error is set when the mechanical tolerances of the airgap parameter are out of range. This information is sent until power supply turns off.	The mechanical mounting must be adjusted.	2
Cells default	0	1	0	2	Red	This error occurs when a magnetic cell is temporary or completely out of order. This error is sent at each concerned frame.	Check the sensor integrity.	3
Need self-calibration	1	0	0	4	Orange	To get the best performances, a self-calibration is required. This information is available until power supply turns off.	The self-calibration shall be start.	4
Self-calibration error	1	0	1	5	Orange	This warning occurs when the self-calibration is not ended correctly. The factory settings are restored. This information is available until power supply turns off.	The self-calibration shall be restarted.	5
Multi-turn counter error	1	1	0	6	Green	This warning occurs when at the power on the sensor has detected an excessive displacement during the power off. This warning and the multi-turns counter are reset at the next power on.	No action required.	6
Internal angle correction	1	1	1	7	Orange stealthily	This warning occurs when the sensor has performed an internal correction error. This warning is sent at each concerned frame.	It is advisable to adjust the mechanical assembly or to perform a self-calibration.	7 (lowest)

SSI INTERFACE (Standard Output Format)

TABLE 1 - SSI CONNECTOR	
PIN NO.	NAME
1	V _{CC} power supply
2	CLK+
3	CLK-
4	DATA+
5	DATA-
6	GND power supply

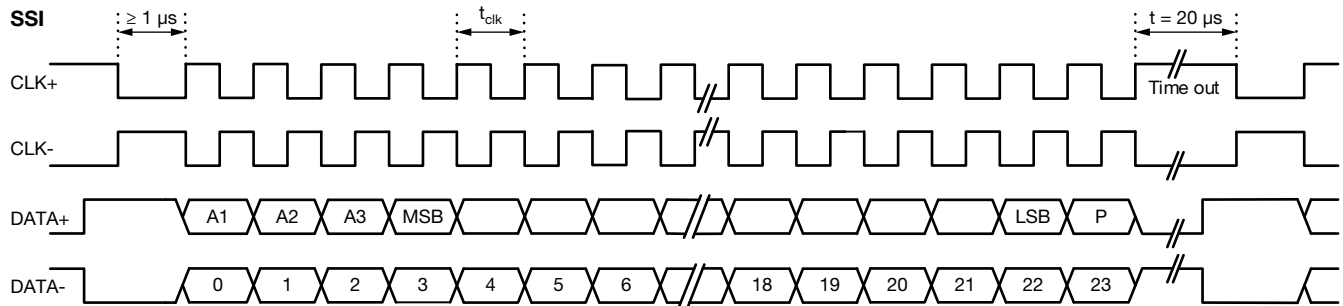

Fig. 3 - SSI Chronogram

TABLE 2 - SSI PARAMETERS	
PARAMETER	INFORMATION
CLK differential interface	RS422 according to the EIA-RS422
DATA differential interface	
Output DATA	Binary two's complement left aligned
Clock frequency (t_{clk})	100 kHz to 3 MHz
Data bit status	3
Data bits (angle value)	19
Parity bit	ODD
Time out (time between two requests)	20 μs minimum

TABLE 3 - SSI DATA BITS FORMAT	
ANGLE VALUE SSI DATA BITS FORMAT	
FRAME BITS (SSI CHRONOGRAM FIG. 3)	FUNCTION
Bit 0	Status bit A1
Bit 1	Status bit A2
Bit 2	Status bit A3
Bit 3	Data MSB
Bit 21	Data LSB
Bit 22	Always = 0
Bit 23	Parity

BISS-C INTERFACE (Optional)

TABLE 4 - BISS-C CONNECTOR	
PIN NO.	NAME
1	V _{CC} power supply
2	CLK+
3	CLK-
4	DATA+
5	DATA-
6	GND power supply

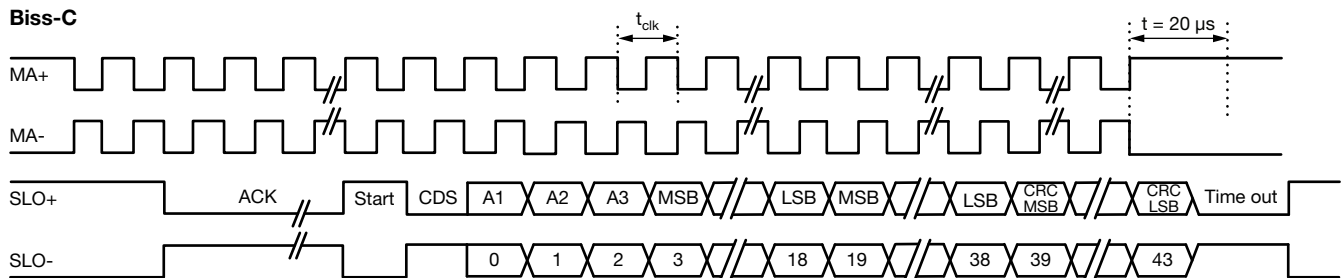

Fig. 4 - Biss-C Chronogram

TABLE 5 - BISS-C PARAMETERS	
PARAMETER	INFORMATION
Biss-C configuration	Point to point (multi-slave not supported)
CLK and data differential interface	RS422 according to the EIA-RS422
Output DATA	Left aligned
Clock frequency (t _{clk})	5 MHz maximum (3 MHz tested)
ACK	12 bits always equal to 0
Start	1 bit always equal to 1
CDS	1 bit always equal to 0
Data bit status	3
Data bits (angle value)	19 (see Table 6)
CRC	6 bits inverted, $P(x) = X^3 + X^1 + 1$, (0 x 43)
Time out (time between two requests)	20 µs minimum

TABLE 6 - BISS-C DATA BITS FORMAT	
ANGLE VALUE BISS-C DATA BITS FORMAT	
FRAME BITS (BISS-C CHRONOGRAM FIG. 4)	FUNCTION
Bit 0	Status bit A1
Bit 1	Status bit A2
Bit 2	Status bit A3
Bit 3	Data MSB
Bit 21	Data LSB
Bit 22	Always = 0
Bit 23	CRC MSB
Bit 28	CRC LSB

SPI INTERFACE (Optional)

TABLE 7 - SPI CONNECTOR	
PIN NO.	NAME
1	V _{CC} power supply
2	CLK
3	DATA
4	CS
5	NC
6	GND power supply

SPI Slave Mode

Fig. 5 - SPI Chronogram

TABLE 8 - SPI PARAMETERS	
PARAMETER	INFORMATION
SPI configuration	Slave mode only
CLK and DATA	TTL 3.3 V or 5 V
Output DATA	Left aligned
Clock frequency (t_{clk})	Up to 4 MHz
t_s (time to start)	1 μ s minimum
Data bit status	3
Data bits (angle value)	19
Parity bit	ODD
Time out (time between two requests)	6 μ s minimum

TABLE 9 - SPI DATA BITS FORMAT	
ANGLE VALUE SPI DATA BITS FORMAT	
FRAME BITS (SPI CHRONOGRAM FIG. 5)	FUNCTION
Bit 0	Status bit A1
Bit 1	Status bit A2
Bit 2	Status bit A3
Bit 3	Data MSB
Bit 21	Data LSB
Bit 22	Always = 0
Bit 23	Parity

OPTIONAL MULTI-TURNS COUNTER

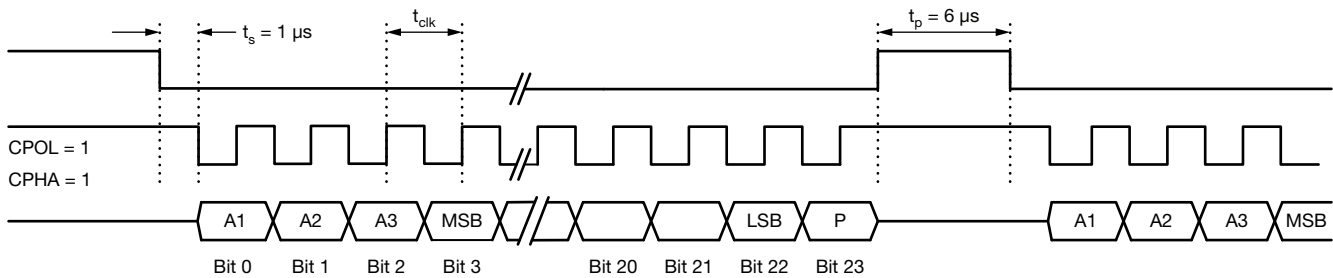
First Possible Option: Counting of Turns Without Battery Backup Connector and Memorization of Last Position Before Power Off!

In normal operation when the power is on, the counting of the turns is made in the two directions, clockwise and anticlockwise. The maximum value of the counter is -32 768 anticlockwise turns to +32 767 clockwise turns. When the counter reaches the maximum value of 32 767, the next counter value is set to -32 768. When it reaches the minimum value of -32 768, the next value is set to 32 767.

The value of the turn counter is sent in the output frame in two complement. No counting during power off. When the power is off, the last position before power cutting (value of the multi-turn counter and value of the angle) is memorized in a non-volatile memory and the encoder can accept (during power off) a movement of encoder up to ± 90° to calculate and release the new position as soon as the power comes back.

The number of non-volatile memory in write-in cycles is unlimited.

At the power on, if the variation of the angle is superior to ± 90°, the error flag of the frame is set and the multi-turn counter is reset at the next power on. This procedure could be used to reset the multi-turns counter.

The multi-turns counter is also reset when the sensor enters in the self-calibration mode.

Second Possible Option: Counting of Turns With Battery Backup Across Connector

After the power off, if the sensor turns, the number of revolutions are counted internally. The counting is made in the two directions, clockwise and anticlockwise. The maximum value of the counter is -32 767 anticlockwise turns to +32 767 clockwise turns. When the counter reaches the maximum value of 32 767, the next counter value is set to -32 768. When the counter reaches the minimum of -32 768, the next value is set to 32 767.

During the power is off, no data is sent to the output. With the backup battery connector plugged to external battery, with low consumption, the encoder counts the number of turns and stocks this data in memory. As soon as the power comes back, the encoder releases the data of number of turns and continues to count in normal conditions.

The multi-turns counter is also reset when the sensor enters in the self-calibration mode.

MULTI-TURNS SSI OUTPUT FORMAT

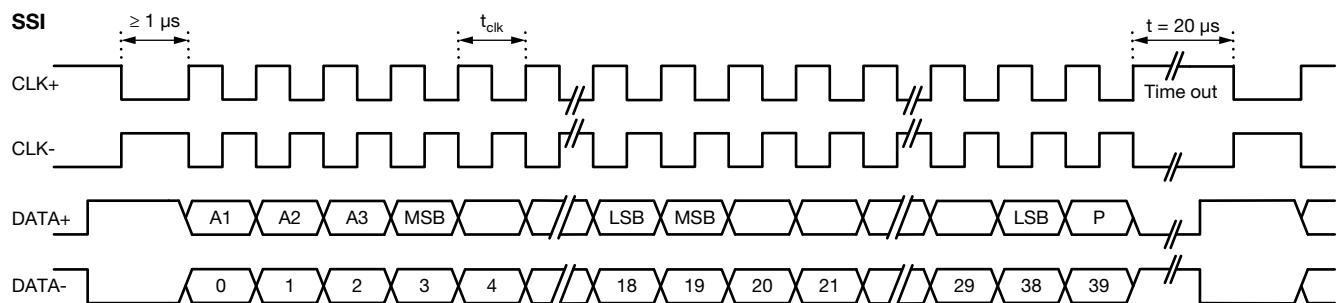

Fig. 6 - SSI Multi-Turns Chronogram

TABLE 10 - SSI MULTI-TURN DATA BITS FORMAT				
SSI DATA BITS FORMAT				
DATA BIT	MSB	LSB	DATA BITS LENGTH	INFORMATION
Status bits	Frame bit 0	Frame bit 2	3 bits	See section "Self-Monitoring"
Multi-turns counter	Frame bit 3	Frame bit 18	16 bits	See Fig. 6
Angle value	Frame bit 19	Frame bit 37	19 bits	See Table 3
Parity	Frame bit 39	-	1 bit	

MULTI-TURNS BISS-C OUTPUT FORMAT

Fig. 7 - Biss-C Multi-Turns Chronogram

TABLE 11 - BISS-C MULTI-TURN DATA BITS FORMAT				
BISS-C DATA BITS FORMAT				
DATA BIT	MSB	LSB	DATA BITS LENGTH	INFORMATION
Status bits	Frame bit 0	Frame bit 2	3 bits	See section "Self-Monitoring"
Multi-turns counter	Frame bit 3	Frame bit 18	16 bits	See Fig. 7
Angle value	Frame bit 19	Frame bit 38	19 bits	See Table 6
CRC	Frame bit 39	Frame bit 44	6 bits	

MULTI-TURNS SPI OUTPUT FORMAT

Fig. 8 - SPI Multi-Turns Chronogram

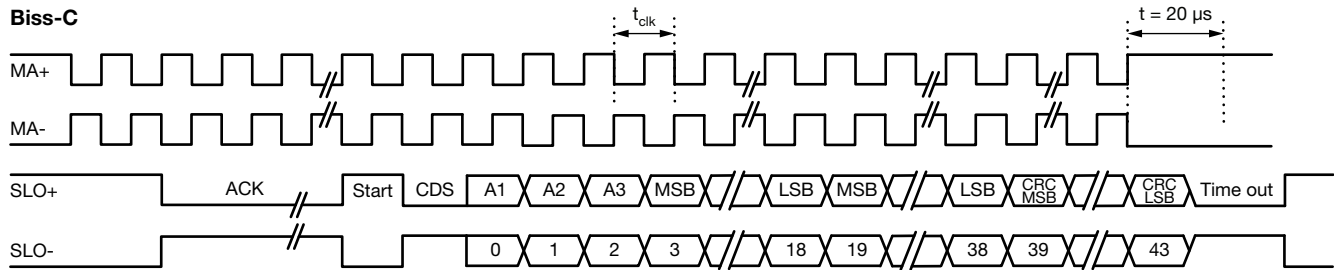
TABLE 12 - SPI MULTI-TURN DATA BITS FORMAT				
SPI DATA BITS FORMAT				
DATA BIT	MSB	LSB	DATA BITS LENGTH	INFORMATION
Status bits	Frame bit 0	Frame bit 2	3 bits	See section "Self-Monitoring"
Multi-turns counter	Frame bit 3	Frame bit 18	16 bits	See Fig. 8
Angle value	Frame bit 19	Frame bit 38	19 bits	See Table 9
Parity	Frame bit 39	-	1 bit	

OPTIONAL BATTERY BACKUP CONNECTOR

- Header on the PCB: Hirose SMD 7 106 (666-1001-0-21)
- Crimp socket: Hirose DF58-2S-1.2C (Hirose number 666-1006-0 00)
- Crimp contact: Hirose DF58-2830SCF (Hirose number 666-1011-0 00)

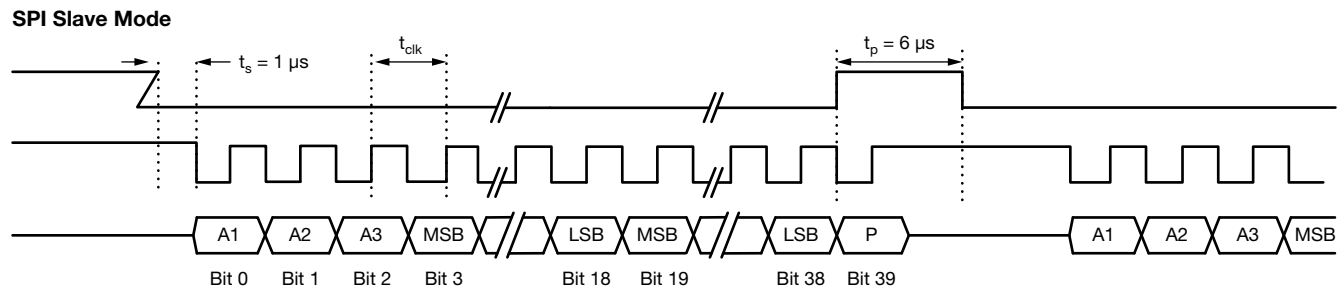
MOUNTING INFORMATION (All Versions)

SENSOR DIMENSIONS

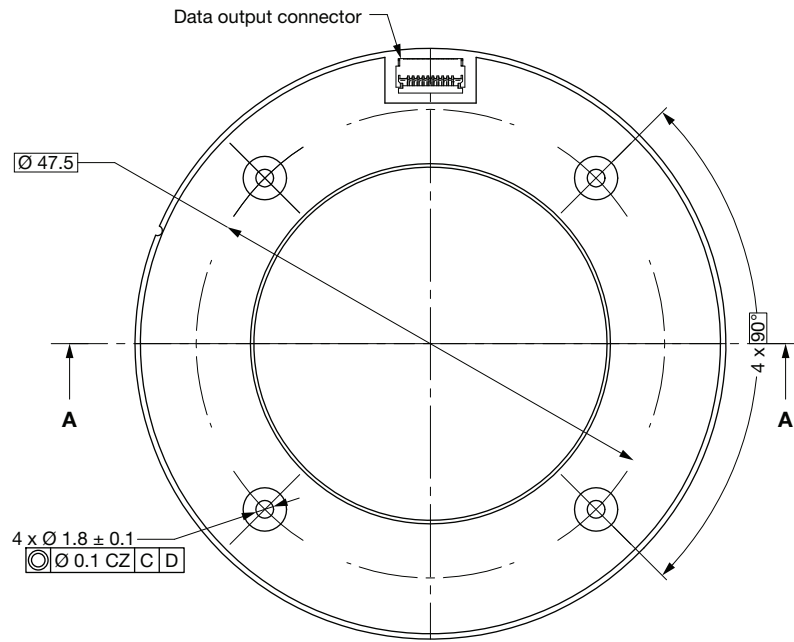

Stator

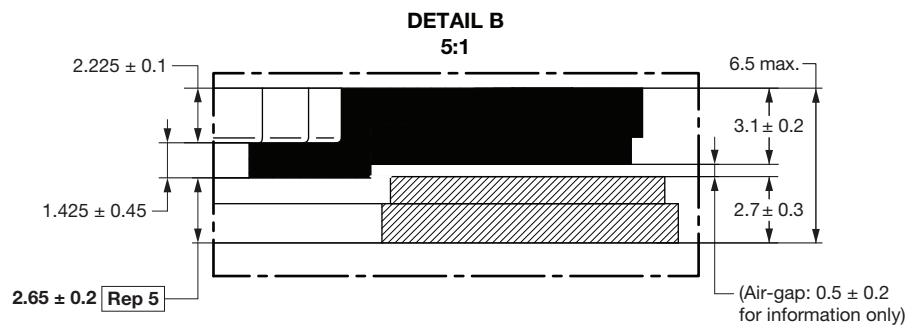
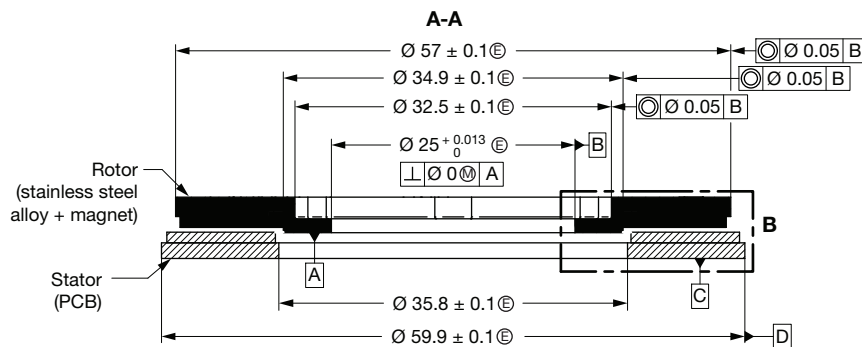

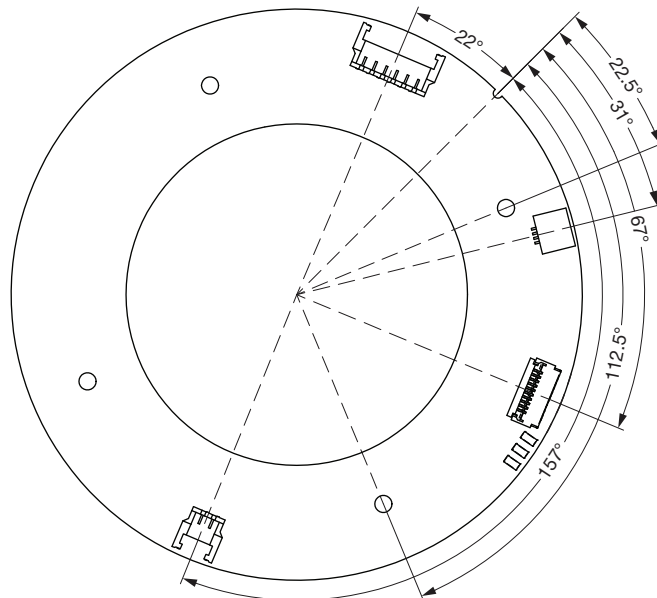
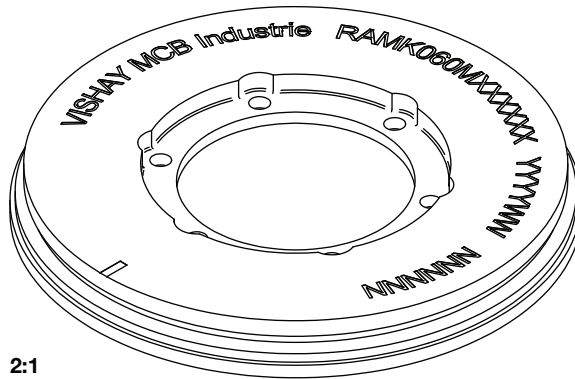
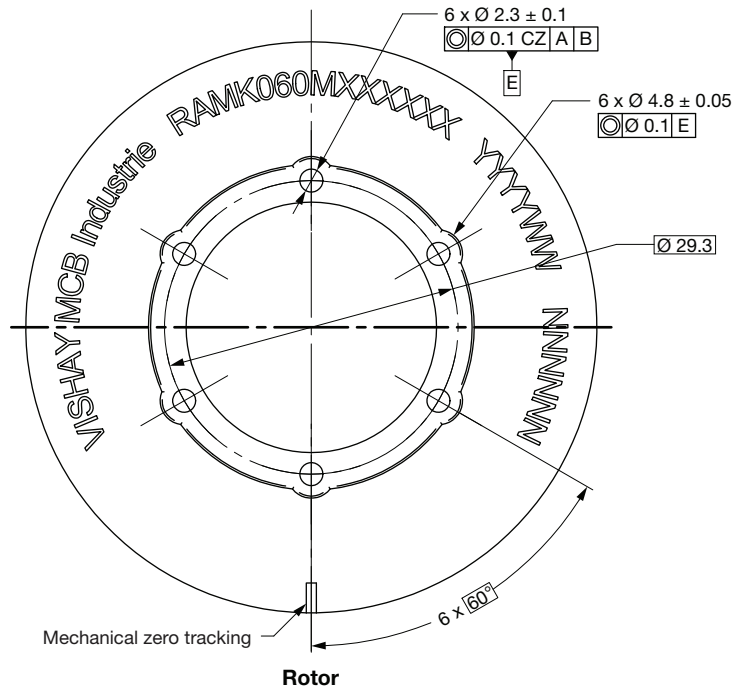

MOUNTING DATA AND SELF-MONITORING

After the mounting and throughout the use of the sensor, the encoder provides across the LED colors and also across data bits of self-monitoring the status of correct mounting and of correct operation. Look at section “Self-Monitoring” and the table “Summary” in section “Approach No. 2”, “Self-Calibration Procedure” of §1.

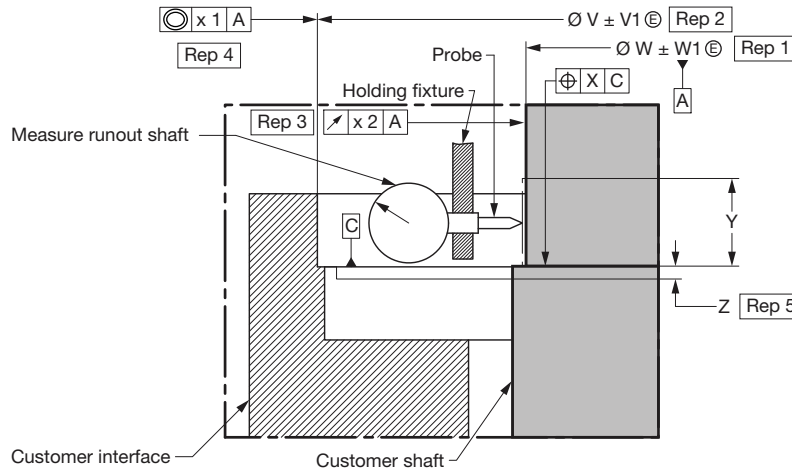
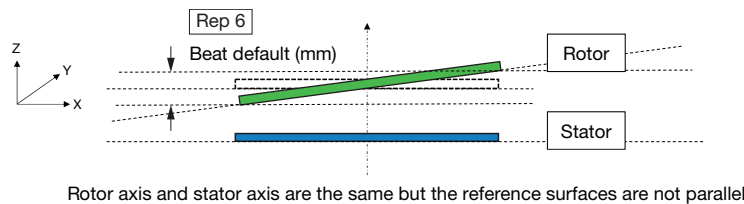

Fig. 9 - Mounting Detail



Rotor axis and stator axis are the same but the reference surfaces are not parallel

Fig. 10 - Beat

APPROACH NO. 1: TOTALLY PLUG AND PLAY WITHOUT SELF-CALIBRATION

Comment: it is the case for the customer’s equipment whose mechanical tolerances are under control (requirements described in Table 13).

TABLE 13 - RECOMMENDED DIMENSIONS AND TOLERANCES OF CUSTOMER INTERFACES		
Rep 1	Customer shaft diameter for centering of the rotor (see Fig. 9)	25 mm + 0 mm / - 0.010 mm
Rep 2	Customer interface diameter for centering of the stator (see Fig. 9)	60 mm + 0.060 mm / 0 mm
Rep 3	Diameter runout of the customer shaft for the rotor centering (see Fig. 9)	< 0.005 mm
Rep 4	Concentricity of the stator centering diameter versus shaft centering diameter (see Fig. 9)	< 0.020 mm
Rep 5	Position of the stator reference bottom surface versus rotor reference bottom surface (see Fig. 9)	2.65 mm ± 0.1 mm
Rep 6	Total beat included in the air-gap between Ref. C (rotor) and Ref. D (stator) (see Fig. 10)	< 0.2 mm



APPROACH NO. 2: SELF-CALIBRATION

Comment: it is the case for the customer's equipment whose mechanical tolerances are NOT under the tolerances described in Approach No. 1, a self-calibration can be used to compensate the misalignment (= eccentricity between rotor axis and stator axis) and the runout of the customer shaft for the rotor centering (eccentricity mounting of the rotor).

Other case where the self-calibration has to be used, it is when the sensor sets the auto-calibration flag (conditions to use the self-calibration procedure: Table 14).

Self-Calibration Procedure

1. How to know if the encoder needs a self-calibration

- a. Mount the encoder
b. Plug the connector
c. Turn-on the power supply
d. Turn the rotor (at least 360°)
e. Look at the LED color

Case 1 Green LED: ON
Red LED: OFF
Orange LED: OFF The encoder is ready to be used with full performances

Case 2 Green LED: OFF
Red LED: ON
Orange LED: OFF Bad mechanical position, adjust the mechanical position

Case 3 Green LED: OFF
Red LED: OFF
Orange LED: ON Do the self-calibration

Table with 3 columns: LED COLOR, STATUS, ACTION. Rows include Green (Ready to use with full performances), Orange (The resolution and / or the accuracy might be out of specification), Red (Bad mechanical position), and No light (No power).

Reminder: similar data are available across the output frame "status bits of self-monitoring":

- "Normal operation" = green color
• "Need self-calibration" = orange color
• "Mechanical mounting error" = red color

2. How to do the self-calibration

- a. The encoder is mounted, the connector is unplug
b. Plug the shunt supplied by Vishay and turn-on the power supply (the red LED is blinking)
c. Turn the rotor with a maximum rotation speed of 10 rpm (at least 360°) (acquisition of data = the orange LED is blinking)
d. When the green and orange LEDs are blinking, the correction calculation is in progress
e. When the green LED is blinking, the correction calculation is finished
f. Turn off the power supply and unplug the shunt
g. Plug the connector, turn-on the power supply, turn the rotor (at 360°) and look at the LED color.
Green LED: ON | Red LED: OFF | Orange LED: OFF
h. The encoder is ready to be used with full performances

Note

- The procedure of self-calibration is also described in video available to ask for Vishay

The self-calibration is operational when the requirements are in accordance with Table 14.

TABLE 14 - RECOMMENDED DIMENSIONS AND TOLERANCES OF CUSTOMER INTERFACES TO USE THE SELF-CALIBRATION PROCEDURE

Rep 3	Diameter runout of the customer shaft for the rotor centering (included gap between customer shaft and inner rotor diameter) (see Fig. 9)	< 0.05 mm
Rep 4	Misalignment: concentricity of the stator centering diameter versus shaft centering diameter (included tolerances of customer holder and stator interface) (see Fig. 9)	± 0.4 mm
Rep 5	Position of the stator reference bottom surface versus rotor reference bottom surface (see Fig. 9) (air-gap: the condition of previous line avoids to measure the air-gap)	2.65 mm ± 0.2 mm (air-gap = 0.5 mm ± 0.2 mm)
Rep 6	Total beat included in the air-gap between Ref. C (rotor) and Ref. D (stator) (see Fig. 10)	< 0.2 mm

- Recommended screws for the rotor: M2 ISO 4762 (stainless steel A4) with recommended torque = 0.3 Nm ± 10 % + narrow washer M2 NFE 25514 “Z” type (stainless steel A4) thickness 0.5 mm. It is recommended to add glue on screws threads function of environmental and use conditions
- Recommended screws for the stator: M1.6 ISO 1207 (stainless steel A4, screw head diameter ≤ 3.2 mm and screw head height ≤ 1 mm) with recommended torque = 0.10 Nm ± 10 % + washer M1.6 DIN 125 (**insulated raw material**) thickness 0.3 mm. It is recommended to add glue on screws function of environmental and use conditions

OTHER INFORMATION



ATTENTION!
Observe Precautions for Handling Electrostatic Sensitive Devices!



Do not use magnetic parts around the encoder!

WARNING: the rotor and the stator must have the same serial number!

- Do not damage the magnetic disk surface
- Do not put the disk in contact with metallic particles
- Do not use cleaning product or chemical product



Disclaimer

ALL PRODUCT, PRODUCT SPECIFICATIONS AND DATA ARE SUBJECT TO CHANGE WITHOUT NOTICE TO IMPROVE RELIABILITY, FUNCTION OR DESIGN OR OTHERWISE.

Vishay Intertechnology, Inc., its affiliates, agents, and employees, and all persons acting on its or their behalf (collectively, "Vishay"), disclaim any and all liability for any errors, inaccuracies or incompleteness contained in any datasheet or in any other disclosure relating to any product.

Vishay makes no warranty, representation or guarantee regarding the suitability of the products for any particular purpose or the continuing production of any product. To the maximum extent permitted by applicable law, Vishay disclaims (i) any and all liability arising out of the application or use of any product, (ii) any and all liability, including without limitation special, consequential or incidental damages, and (iii) any and all implied warranties, including warranties of fitness for particular purpose, non-infringement and merchantability.

Statements regarding the suitability of products for certain types of applications are based on Vishay's knowledge of typical requirements that are often placed on Vishay products in generic applications. Such statements are not binding statements about the suitability of products for a particular application. It is the customer's responsibility to validate that a particular product with the properties described in the product specification is suitable for use in a particular application. Parameters provided in datasheets and / or specifications may vary in different applications and performance may vary over time. All operating parameters, including typical parameters, must be validated for each customer application by the customer's technical experts. Product specifications do not expand or otherwise modify Vishay's terms and conditions of purchase, including but not limited to the warranty expressed therein.

Except as expressly indicated in writing, Vishay products are not designed for use in medical, life-saving, or life-sustaining applications or for any other application in which the failure of the Vishay product could result in personal injury or death. Customers using or selling Vishay products not expressly indicated for use in such applications do so at their own risk. Please contact authorized Vishay personnel to obtain written terms and conditions regarding products designed for such applications.

No license, express or implied, by estoppel or otherwise, to any intellectual property rights is granted by this document or by any conduct of Vishay. Product names and markings noted herein may be trademarks of their respective owners.