

THIS DRAWING IS UNPUBLISHED. RELEASED FOR PUBLICATION
 © COPYRIGHT BY TYCO ELECTRONICS CORPORATION. ALL RIGHTS RESERVED.

LOC	DIST	REVISIONS				
		P	LTR	DESCRIPTION	DATE	DWN
DW	—	A	RELEASED	19JUL07	HH	WK

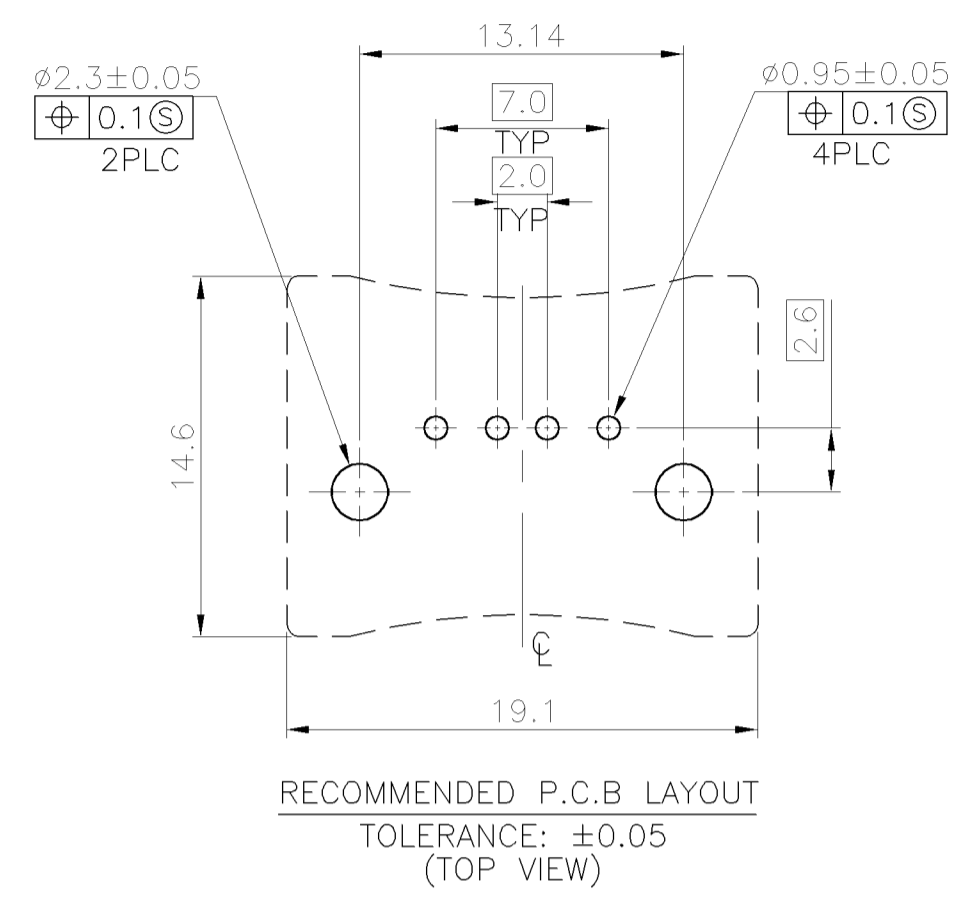

- NOTES:
- MATERIAL:
HOUSING: PA9T WITH 30% GF, UL94V-0, COLOR: BLACK.
LOCKING DEVICE: PA66 WITH 15% GF, UL94V-0, COLOR: BLUE(2718C).
CONTACTS: PHOSPHOR BRONZE, T=0.25mm.
SHELL: BRASS, T=0.30mm.
 - FINISH:
CONTACTS: GOLD (SEE TABLE) PLATED ON CONTACT AREA, 2.54um (100u") MIN. BRIGHT-TIN PLATING ON SOLDER TAILS, 1.27um (50u") MIN. NICKEL UNDERPLATED ALL OVER.
SHELL: 1.27um (50u") MIN. NICKEL PLATED.
 - RECOMMENDED PCB THICKNESS: 1.6mm.
 - WAVE SOLDER CAPABLE TO 265°C PER TYCO TEST SPEC, 109-202.CONDTION B.

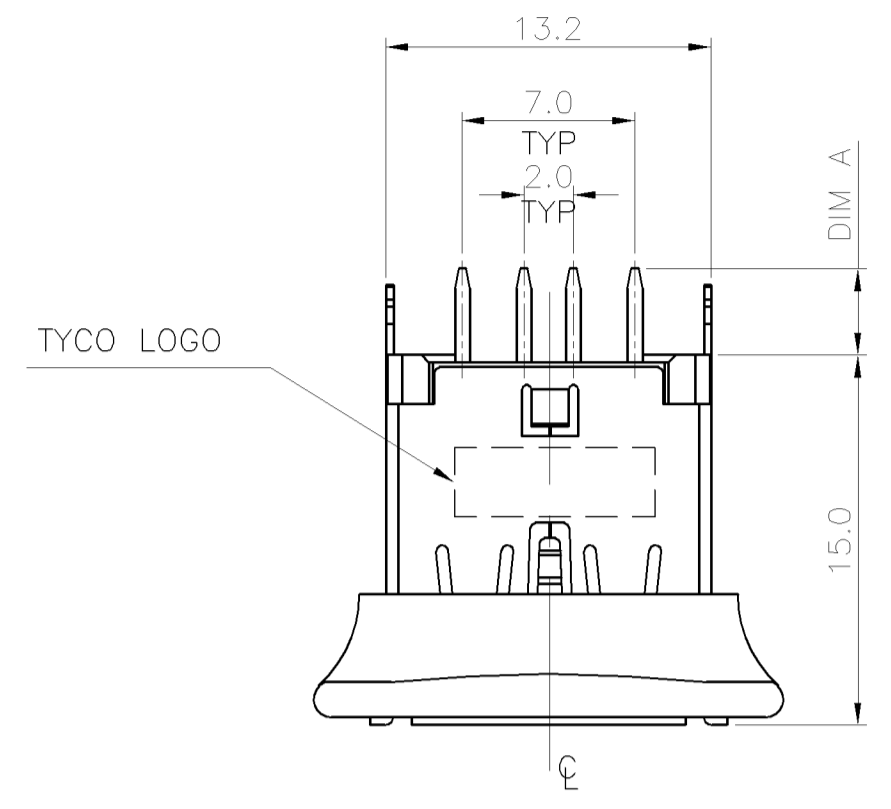
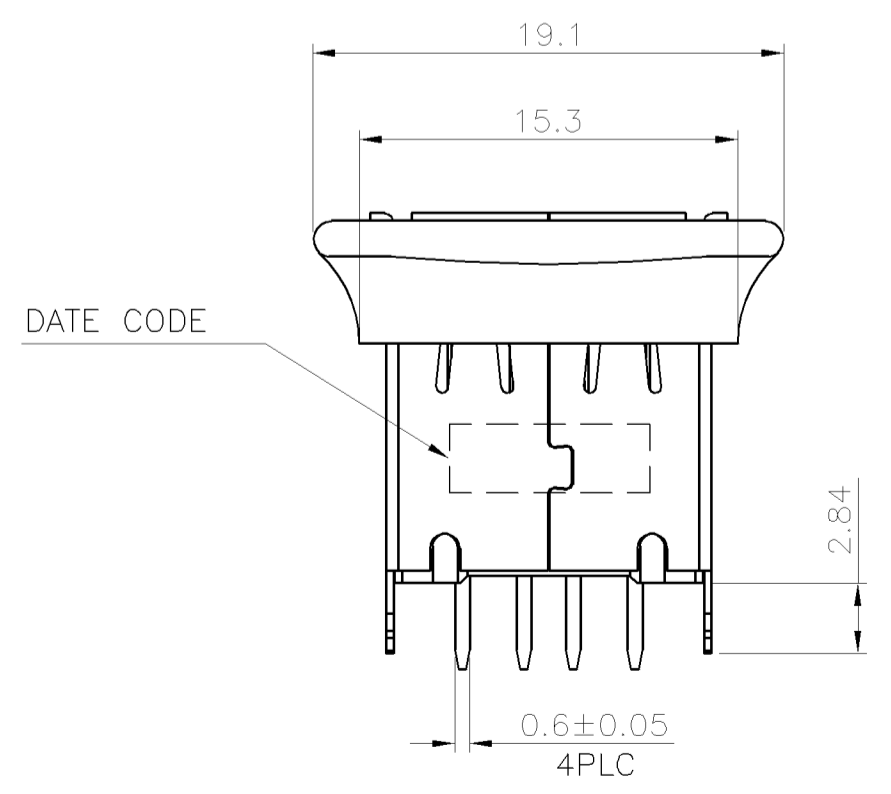
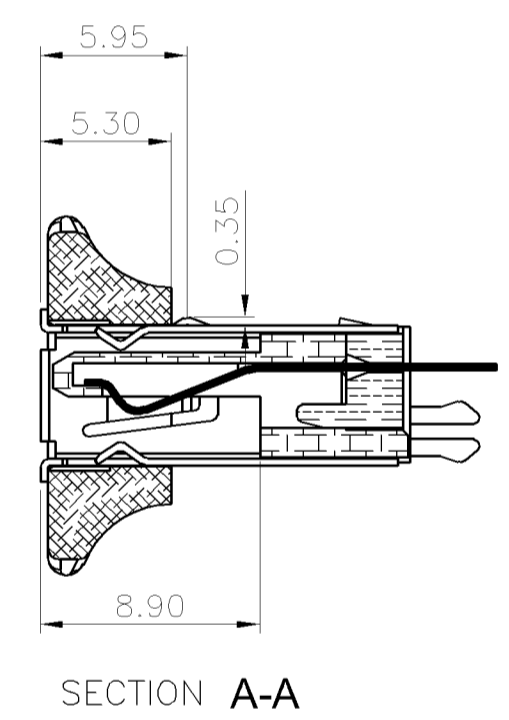
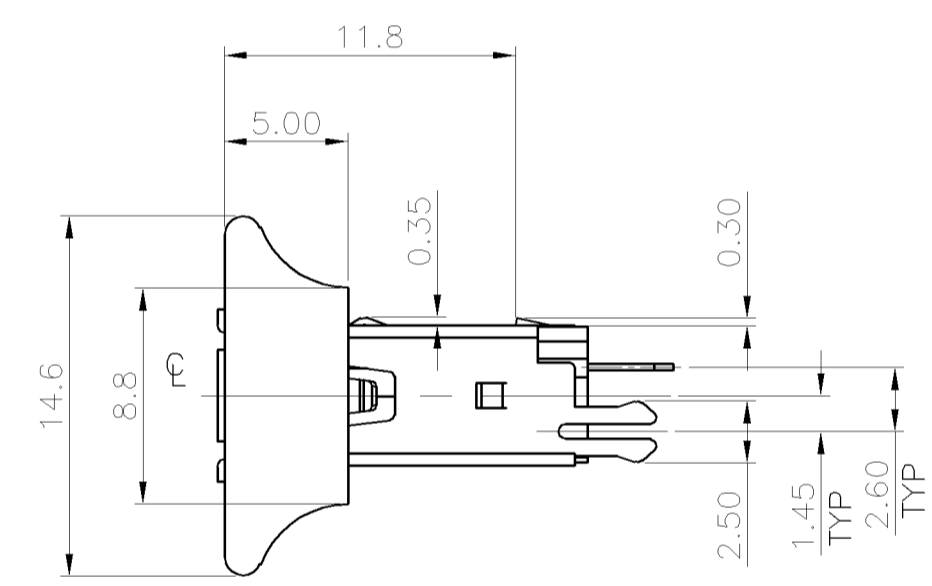
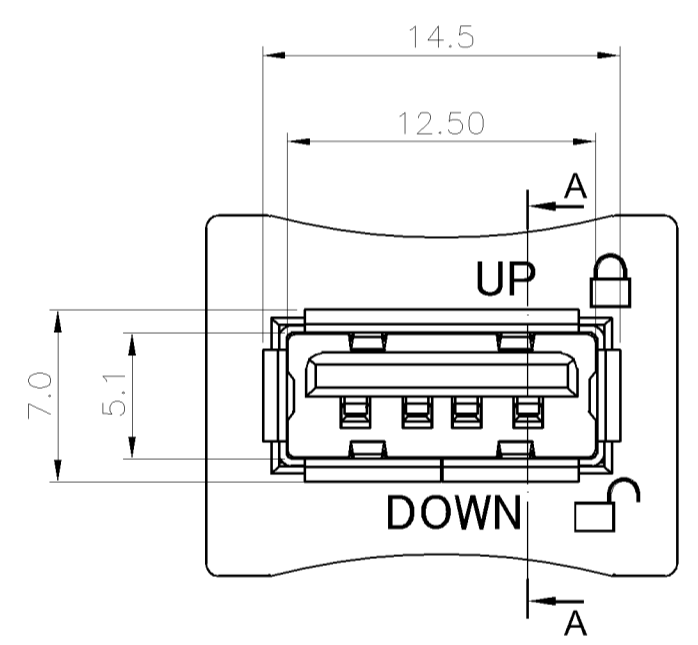

2.84	0.762um (30u")	1-1775690-2
	G/F	1-1775690-1
3.50	0.762um (30u")	1775690-2
	G/F	1775690-1
DIM A	MIN. GOLD	PART NUMBER

THIS DRAWING IS A CONTROLLED DOCUMENT.		DWN H. HUANG 19JUL2007	Tyco Electronics Corporation Taipei, Taiwan			
DIMENSIONS: MM		CHK S. HOU 19JUL2007				
TOLERANCES UNLESS OTHERWISE SPECIFIED:		APVD W.J. KE 19JUL2007	NAME			
0 PLC ± - 1 PLC ± 0.30 2 PLC ± 0.25 3 PLC ± - 4 PLC ± - ANGLES ± 3°		PRODUCT SPEC 108-57519	USB A TYPE, W/LOCKING VERTICAL, DIP			
MATERIAL SEE NOTE		QUALIFICATION TEST REPORT 501-57772	SIZE	CAGE CODE	DRAWING NO	RESTRICTED TO
FINISH SEE NOTE		WEIGHT 2.9 GRAMS	A3	00779	C=1775690	—
CUSTOMER DRAWING			SCALE —	SHEET 1 OF 2	REV A	

P	LTR	DESCRIPTION	DATE	DWN	APVD
		SEE SHEET 1.			

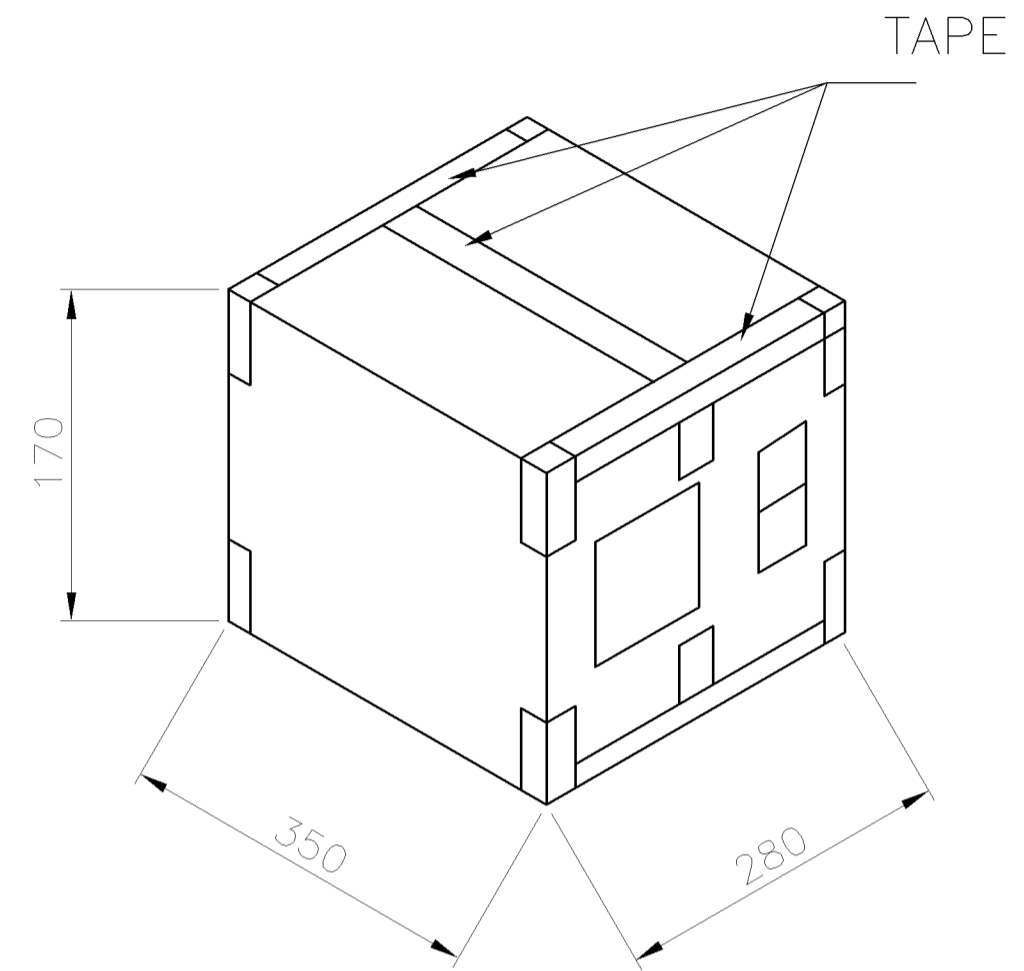
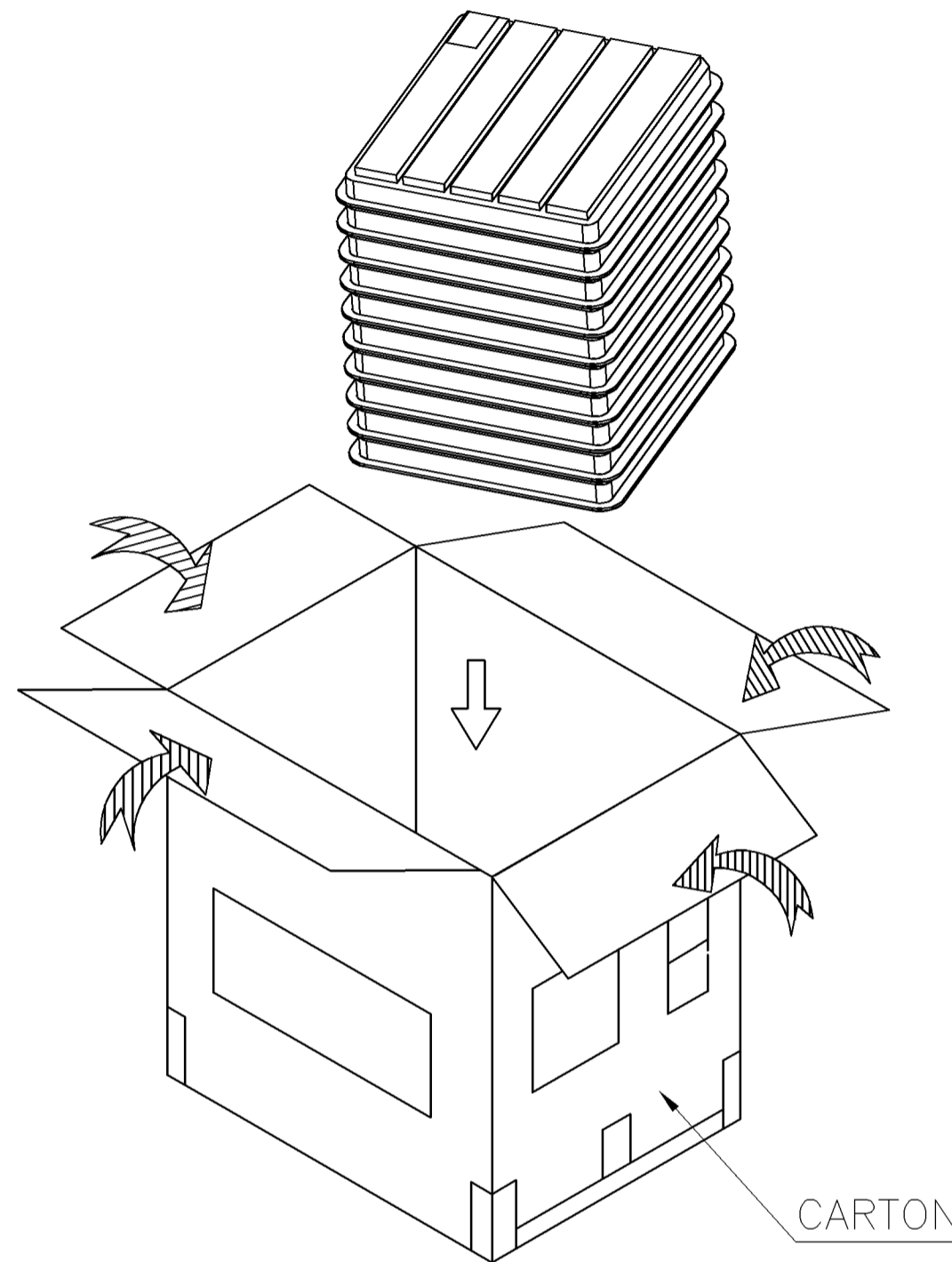
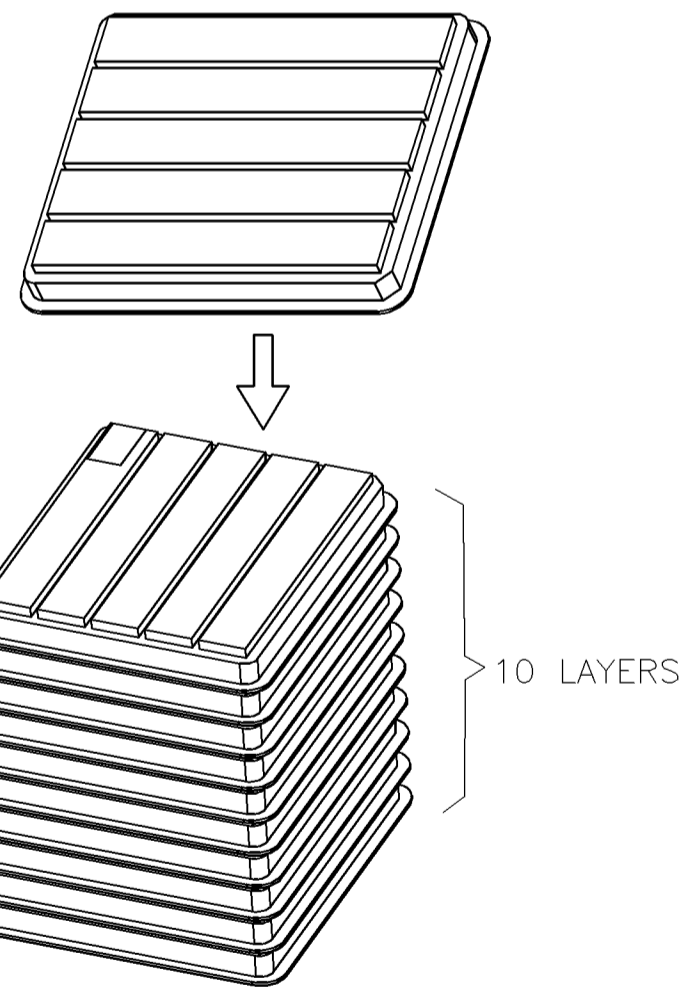
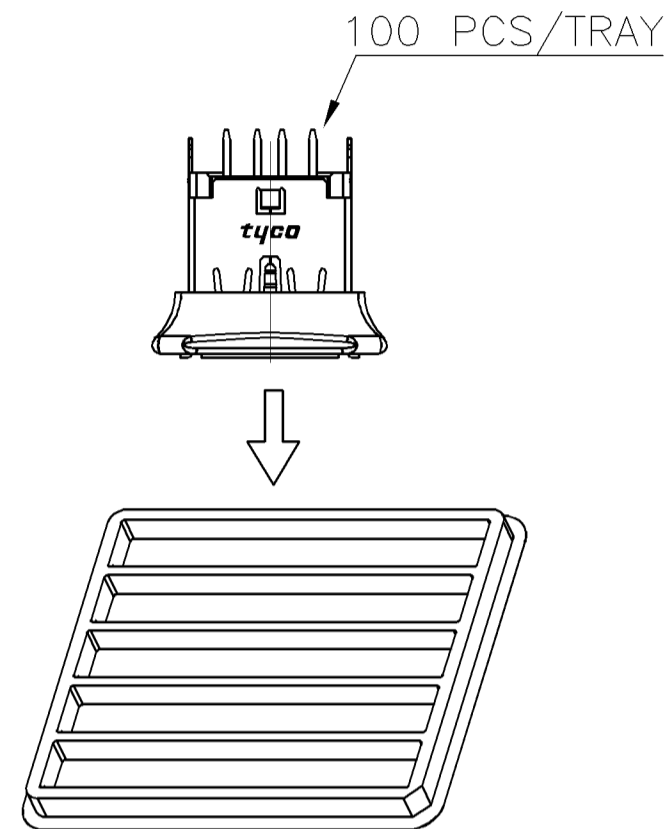

100	10	1000	3.9	2.9
PCS/ TRAY	TRAY/ CARTON	QUANTITY	G/W (KG)	N/W (KG)

THIS DRAWING IS A CONTROLLED DOCUMENT.		DWN H. HUANG 19JUL2007	Tyco Electronics Corporation Taipei, Taiwan	
DIMENSIONS: MM		CHK S. HOU 19JUL2007	NAME	
TOLERANCES UNLESS OTHERWISE SPECIFIED:		APVD W.J. KE 19JUL2007	USB A TYPE, W/LOCKING VERTICAL, DIP	
MATERIAL		PRODUCT SPEC —	SIZE A3	RESTRICTED TO —
FINISH		APPLICATION SPEC —	CAGE CODE 00779	
		WEIGHT —	DRAWING NO C=1775690	
CUSTOMER DRAWING			SCALE —	REV A
			SHEET 2 OF 2	